



# NetSure™ 7100 Series -48 VDC Power System

## Quick Start Guide

Specification Number: 582127000

Model Number: 7100

The information contained in this document is subject to change without notice and may not be suitable for all applications. While every precaution has been taken to ensure the accuracy and completeness of this document, Vertiv assumes no responsibility and disclaims all liability for damages resulting from use of this information or for any errors or omissions. Refer to other local practices or building codes as applicable for the correct methods, tools, and materials to be used in performing procedures not specifically described in this document.

The products covered by this instruction manual are manufactured and/or sold by Vertiv. This document is the property of Vertiv and contains confidential and proprietary information owned by Vertiv. Any copying, use or disclosure of it without the written permission of Vertiv is strictly prohibited.

Names of companies and products are trademarks or registered trademarks of the respective companies. Any questions regarding usage of trademark names should be directed to the original manufacturer.

## **Technical Support Site**

If you encounter any installation or operational issues with your product, check the pertinent section of this manual to see if the issue can be resolved by following outlined procedures.

Visit <https://www.vertiv.com/en-us/support/> for additional assistance.

## TABLE OF CONTENTS

<b>Admonishments Used in this Document</b> .....	<b>v</b>
<b>Important Safety Instructions</b> .....	<b>vi</b>
Safety Admonishments Definitions.....	vi
Safety and Regulatory Statements.....	vi
Déclarations de Sécurité et de Réglementation.....	vi
<b>1 Customer Documentation Package</b> .....	<b>1</b>
<b>2 Physical Installation</b> .....	<b>2</b>
<b>3 Installing Circuit Breakers and Fuses</b> .....	<b>2</b>
<b>4 Make Jumper and Switch Settings</b> .....	<b>10</b>
<b>5 Electrical Connections</b> .....	<b>11</b>
5.1 Important Safety Instructions.....	11
5.2 Make Nominal 208 VAC, 240 VAC, 277 VAC, or 277 VAC / 480 VAC Input and Equipment Grounding Connections (if equipped).....	11
5.3 Make Nominal 400 Volts DC Input and Equipment Grounding Connections (if equipped).....	39
5.4 Make External Alarm, Reference, Monitoring, and Control Connections.....	45
5.4.1 Circuit Card Locations.....	45
5.4.2 System Interface Circuit Card.....	46
5.4.3 IB2 (Controller Interface Board) Connections (if required) (Main Bay Only).....	48
5.4.4 Optional EIB (Controller Extended Interface Board) Connections (if required) (Main Bay Only).....	53
5.4.5 Optional SM-DU+ and Shunt Interface Board.....	58
5.4.6 Connecting a Device or System to the Controller's CAN Bus.....	60
5.5 Make Controller Ethernet Connection (if required).....	61
5.6 Make Bay-to-Bay Communications Cable Connections.....	64
5.7 Installing Bay-to-Bay Busbars (582127000 List 1 with List 2 / List 3) (for system mounted in a relay rack).....	64
5.8 Installing Bay-to-Bay Busbars (582127000 List 1 with List 7 / List 8) (for system mounted in an enclosure).....	64
5.9 Connecting Converter Output Cables 582127000 List 60.....	71
5.10 Make Load Connections.....	74
5.10.1 Recommended Torques.....	74
5.10.2 Load Connections to Single Voltage Distribution Panels.....	75
5.10.3 Load Connections to Dual Voltage Distribution Panels.....	80
5.10.4 Load Connections to Return Bar.....	85
5.10.5 Load Connections to Bulk Output Panel.....	85
5.10.6 Load Connections to GMT Distribution Fuse Block.....	86
5.11 Make Battery Connections.....	87
5.11.1 Recommended Torques.....	87
5.11.2 Battery Connections to Optional Battery Disconnect Distribution Panels.....	87
5.11.3 Battery Connections to Distribution Cabinet Battery Busbars (for system mounted in a relay rack or enclosure).....	91
5.11.4 Battery Connections to Bay-to-Bay Rectifier Busbars (582127000 List 1 with List 2 / List 3) (for system mounted in a relay rack).....	93
5.12 List 93 Battery Tray.....	94
<b>6 Installing the Modules</b> .....	<b>94</b>
6.1 Installing Rectifier or Converter Modules into Spec. No. 588705000 Module Mounting Assemblies.....	94

6.2	Installing Rectifier Modules into Spec. No. 588705500 Module Mounting Assemblies.....	96
6.3	Installing the Rectifier and Converter Modules into Spec. No. 588705300 Module Mounting Assemblies.....	98
6.4	Installing Rectifier Modules into Spec. No. 588705400 Module Mounting Assemblies.....	100
<b>7</b>	<b>Initially Starting, Configuring, and Checking System Operation .....</b>	<b>102</b>
7.1	Initial Startup Preparation .....	102
7.2	Initially Starting the System .....	102
7.3	ACU+ Controller Procedure.....	102
7.4	NCU Controller Procedure .....	110
7.5	Checking System Status.....	115
7.6	Final Steps.....	116

## Admonishments Used in this Document



**DANGER!** Warns of a hazard the reader **will** be exposed to that will **likely** result in death or serious injury if not avoided. (ANSI, OSHA)



**WARNING!** Warns of a potential hazard the reader **may** be exposed to that **could** result in death or serious injury if not avoided. This admonition is not used for situations that pose a risk only to equipment, software, data, or service. (ANSI)



**CAUTION!** Warns of a potential hazard the reader **may** be exposed to that **could** result in minor or moderate injury if not avoided. (ANSI, OSHA) This admonition is not used for situations that pose a risk only to equipment, data, or service, even if such use appears to be permitted in some of the applicable standards. (OSHA)



**ALERT!** Alerts the reader to an action that **must be avoided** in order to protect equipment, software, data, or service. (ISO)



**ALERT!** Alerts the reader to an action that **must be performed** in order to prevent equipment damage, software corruption, data loss, or service interruption. (ISO)



**FIRE SAFETY!** Informs the reader of fire safety information, reminders, precautions, or policies, or of the locations of fire-fighting and fire-safety equipment. (ISO)



**SAFETY!** Informs the reader of general safety information, reminders, precautions, or policies not related to a particular source of hazard or to fire safety. (ISO, ANSI, OSHA)

# **Important Safety Instructions**

## **Safety Admonishments Definitions**

Definitions of the safety admonishments used in this document are listed under “Admonishments Used in this Document” on page v.

## **Safety and Regulatory Statements**

Refer to Section 4154 (provided with your customer documentation) for Safety and Regulatory Statements.

## **Déclarations de Sécurité et de Réglementation**

Reportez-vous à la Section 4154 (fourni avec les documents de votre client) pour les déclarations de sécurité et de réglementation.

# 1 Customer Documentation Package

This document (QS582127000) provides *Quick Start Instructions* for Vertiv™ NetSure™ -48 VDC Power System Model 7100, Spec. No. 582127000.



**NOTE!** 582127000 List 100, 101, 102, and 103 are specific configurations of 582127000. Separate User Instructions and Installation Instructions are provided with these power systems. For 582127000 List 100, 101, 102, and 103; do not use these instructions. Refer to IM582127000100 and UM582127000 for instructions.

The complete Customer Documentation Package consists of...

## **Power System Installation Manual**

- Power System Installation Instructions: IM582127000

## **Vertiv™ NetSure™ ACU+ Controller User Manual**

- ACU+ Controller User Instructions: UM1M820BNA (AC Input Voltage Systems) or UM1M820DNA400 (DC Input Voltage Systems)

## **Vertiv™ NetSure™ NCU Controller User Manual**

- NCU Controller User Instructions: UM1M830BNA (AC Input Voltage Systems)

## **USB Drive with All Customer Documentation**

- Power System Quick Start Guide: QS582127000
- Power System Installation Instructions: IM582127000
- Power System Installation Instructions: IM582127000100 (instructions for List 100, 101, 102, and 103)
- Power System User Instructions: UM582127000
- Power System User Instructions: UM582127000100 (instructions for List 100, 101, 102, and 103)
- ACU+ Controller User Instructions: UM1M820BNA
- ACU+ Controller User Instructions: UM1M820DNA400
- NCU Controller User Instructions: UM1M830BNA
- Rectifier Instructions: UM1R483500e
- Rectifier Instructions: UM1R483500e3
- Rectifier Instructions: UM1R482000e3
- Converter Instructions: UM1C48241500
- Converter Instructions: UM1C400483500e
- Power System "System Application Guide": SAG582127000
- NCU Controller 2nd Ethernet Port Add-On Kit Instructions: IM559252
- NCU Controller 2nd Ethernet Port Retrofit Kit Instructions: IM559251
- Engineering Drawings

- Also provided on the USB drive is a controller configuration drawing and the controller configuration files loaded into the controller as shipped.

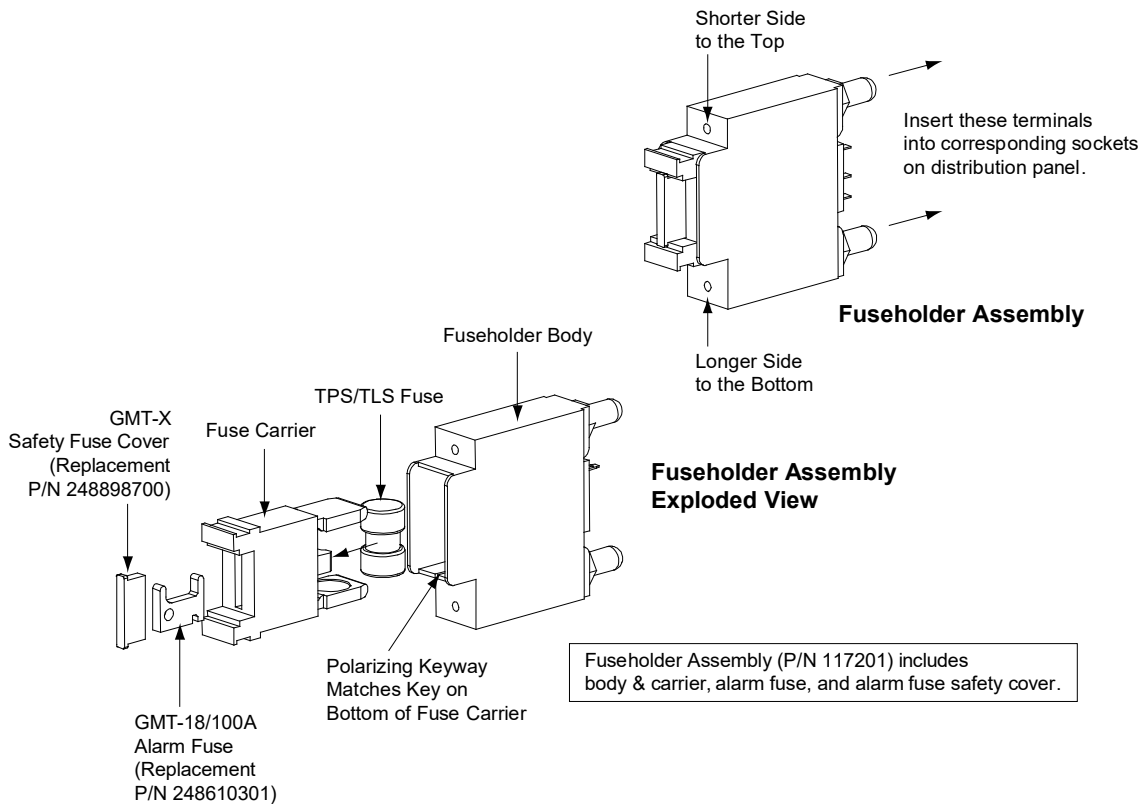
## 2 Physical Installation

To do this...	See this in the Installation Instructions (IM582127000)
Choose a mounting location	<i>General Requirements</i> in the INSTALLING THE SYSTEM section.
Secure the relay rack or enclosure to the floor	<i>Securing the Relay Rack or Enclosure to the Floor</i> in the INSTALLING THE SYSTEM section.
Mount the Power System	<i>Mounting System Components in an Equipment Rack</i> in the INSTALLING THE SYSTEM section.
Install optional lug adapter busbar kits	<i>Installing Optional Lug Adapter Busbar Kits, Part Nos. 534449 and 514714</i> in the INSTALLING THE SYSTEM section.

## 3 Installing Circuit Breakers and Fuses

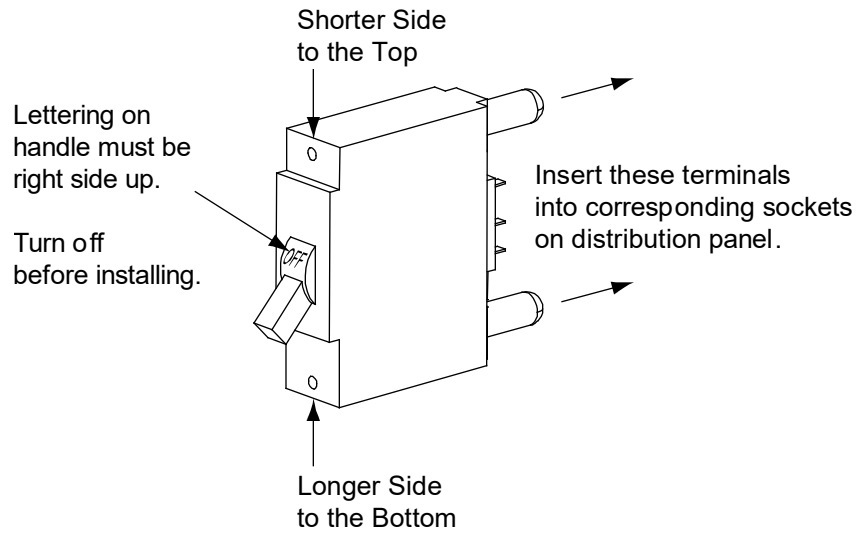
Load and battery distribution devices were factory-installed if ordered with the power system. If additional installation is required, refer to **Figure 1** through **Figure 7**. For detailed procedures, refer to *Installing Circuit Breakers and Fuses* in the INSTALLING THE SYSTEM section of the Installation Instructions (IM582127000).

**Figure 3.1** Installing a Bullet Nose Type Fuseholder and TPS/TLS Fuse

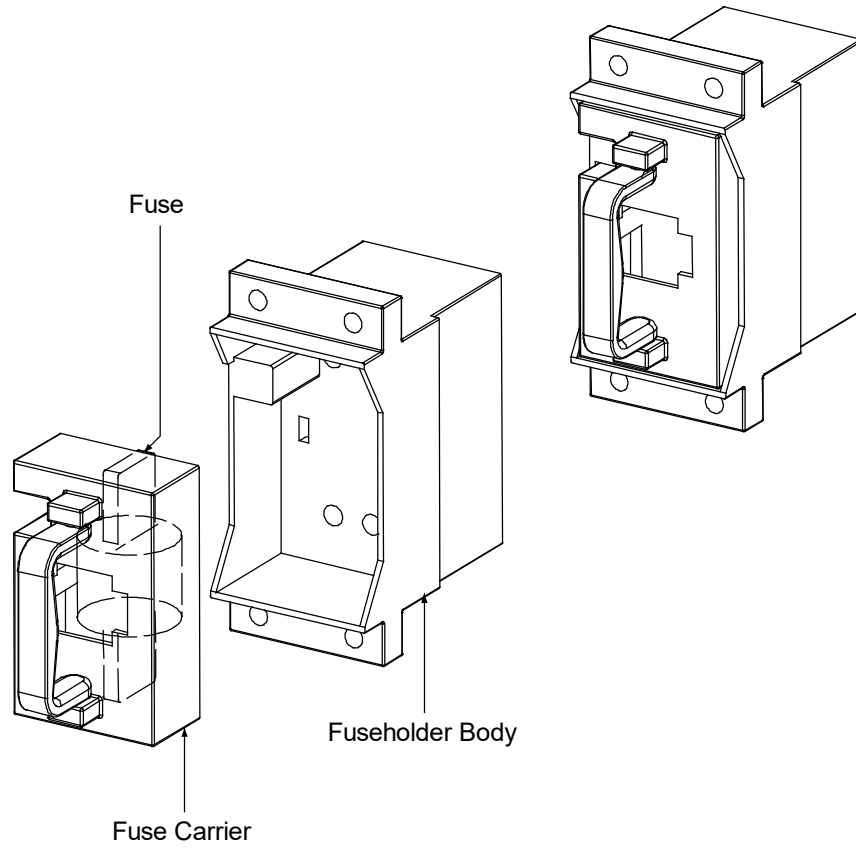




**Figure 3.2** Installing a Bullet Nose Type Circuit Breaker



**Figure 3.3** Installing a TPH Fuse



**Figure 3.4** Installing TPL-B Fuses

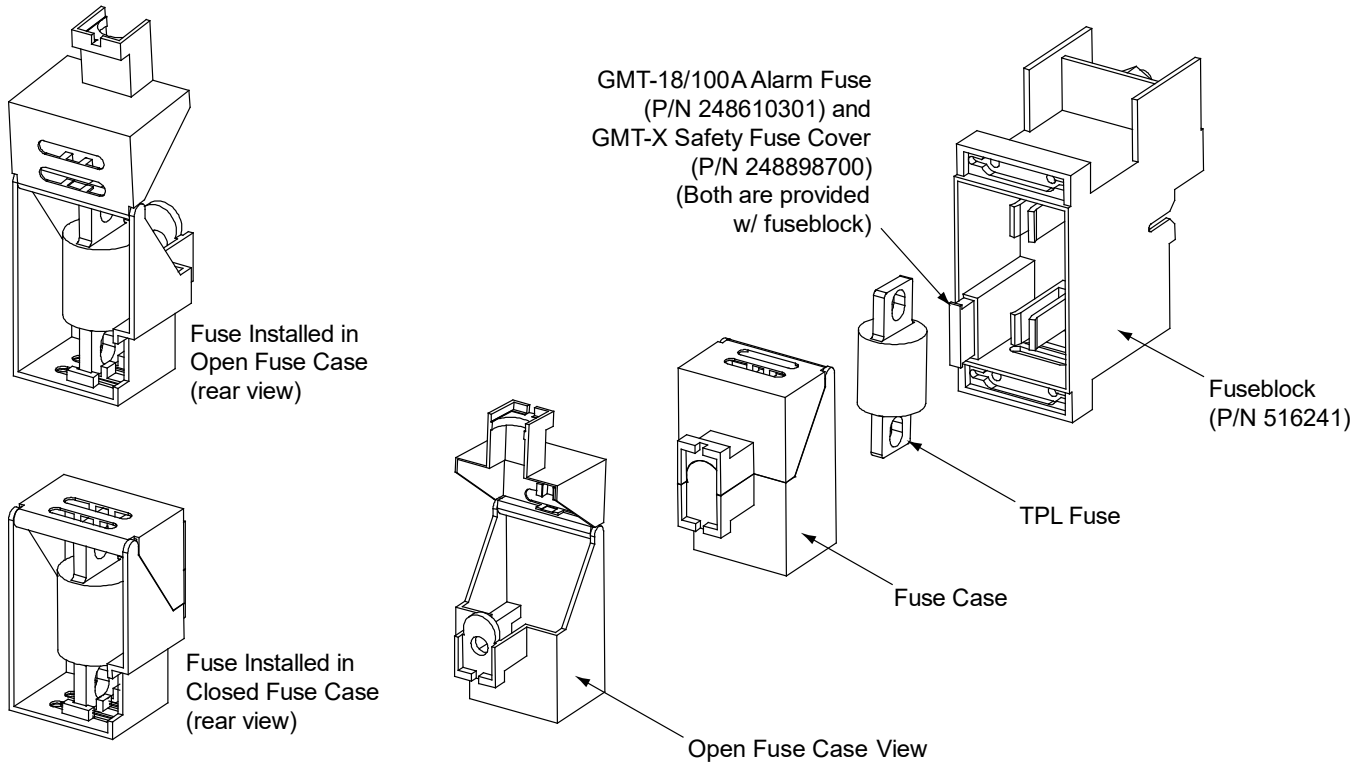
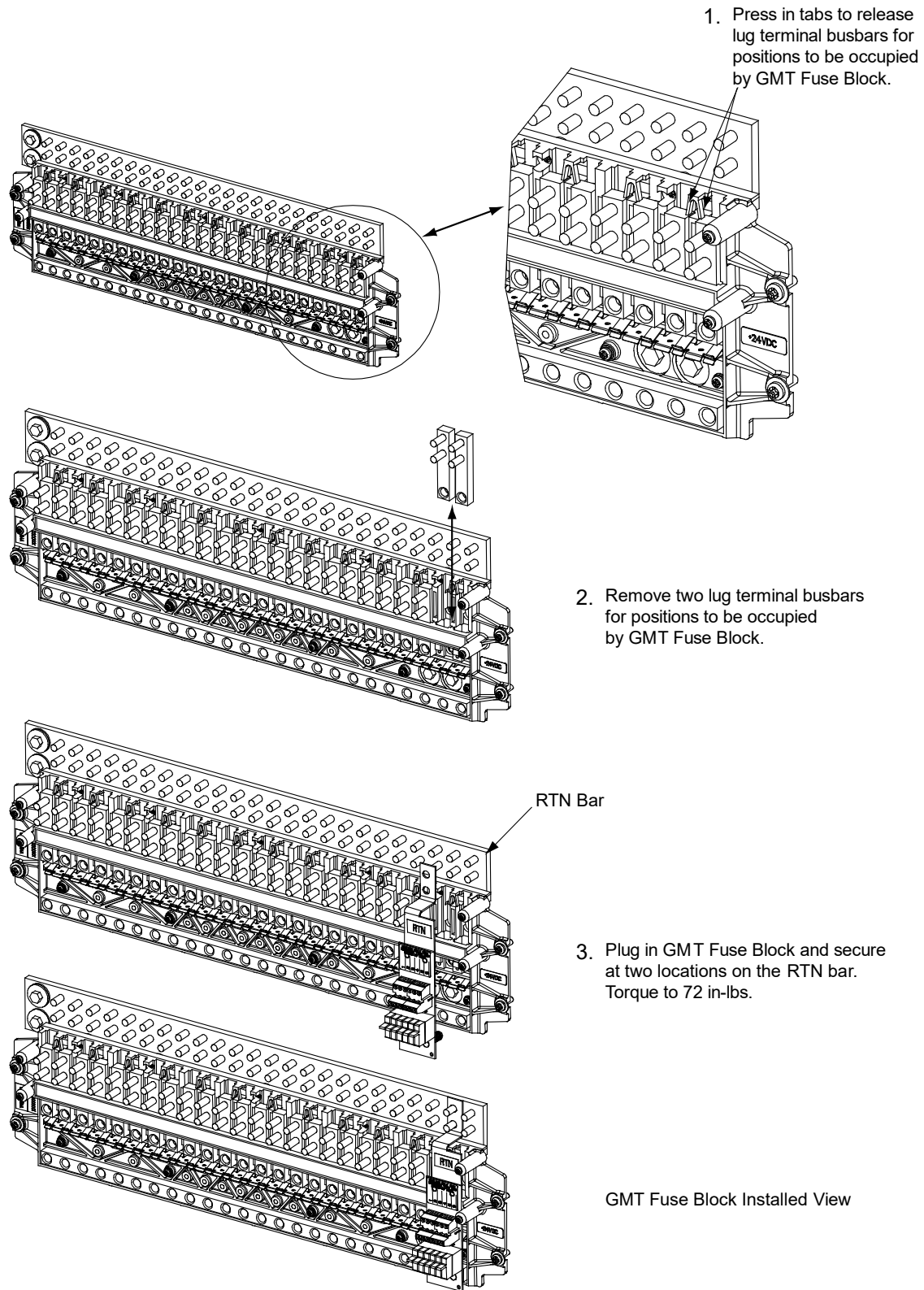
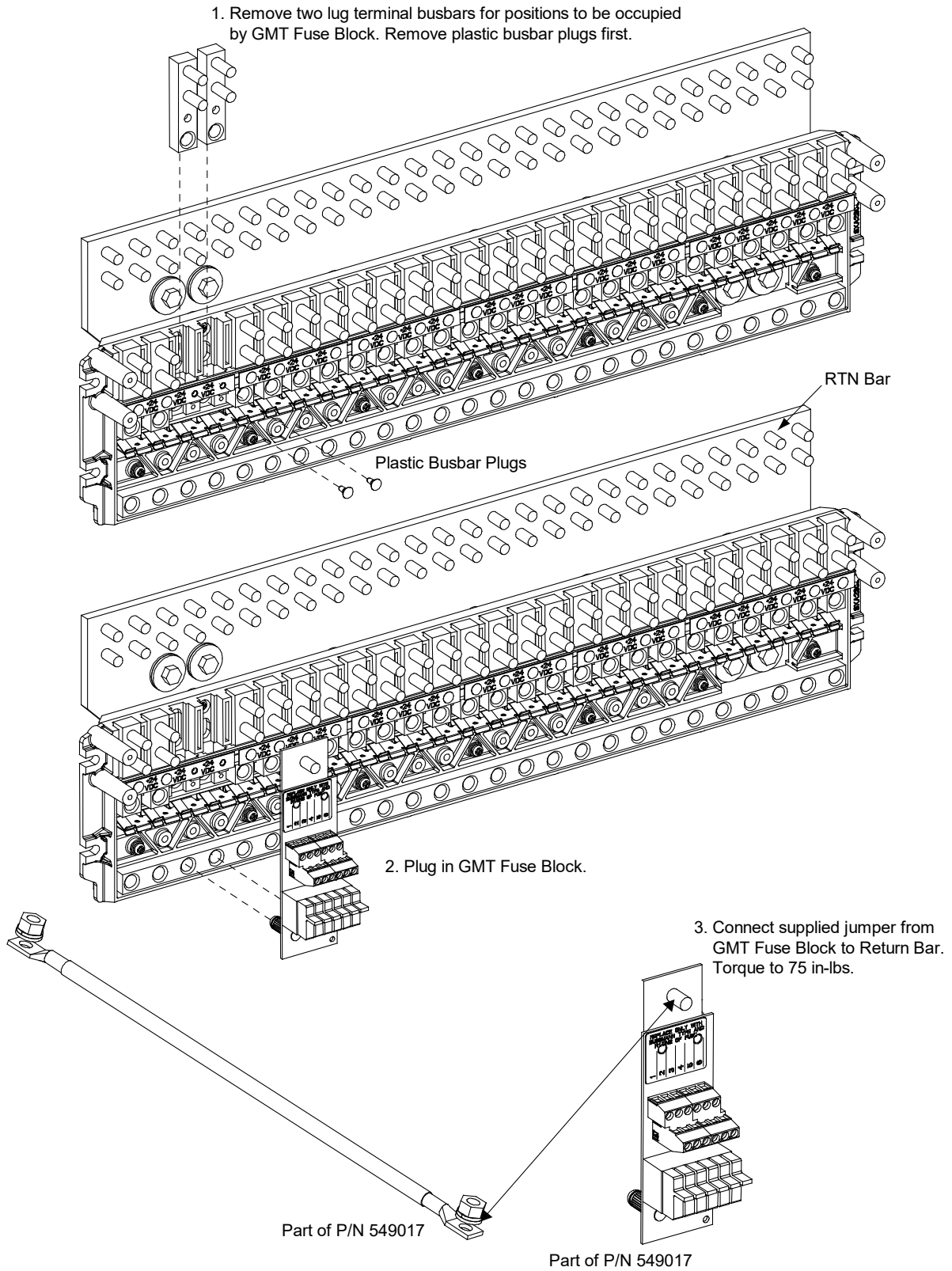


Figure 3.5 Installing an Optional Bullet Nose Type 6-Position GMT Distribution Fuse Block (P/N 550224)

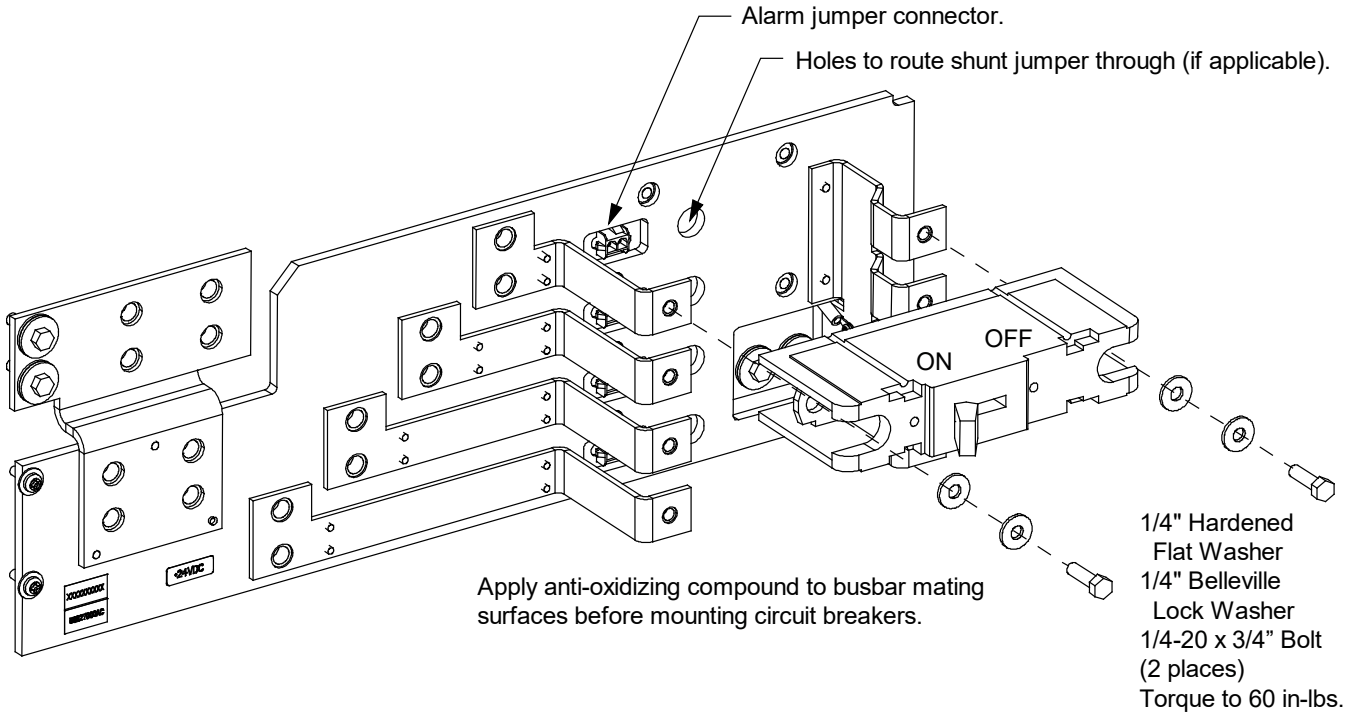


**Figure 3.6** Installing an Optional Bullet Nose Type 6-Position GMT Distribution Fuse Block (P/N 549017)

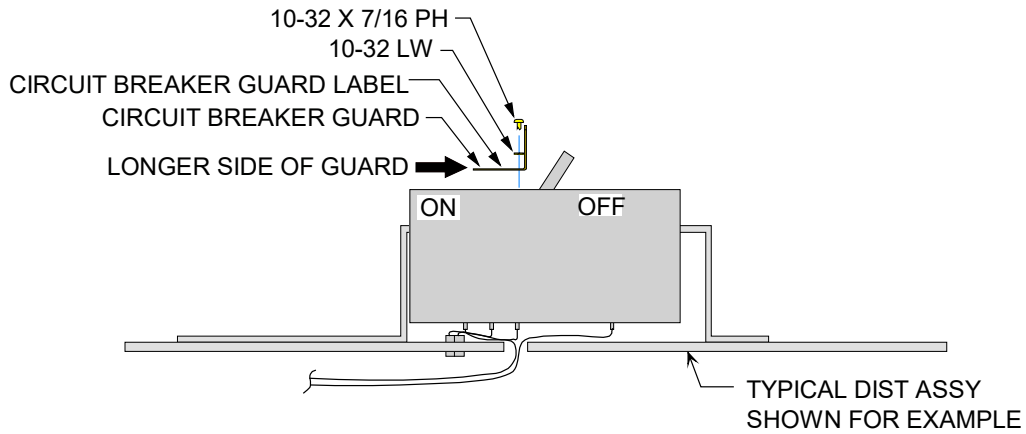


**Figure 3.7** Installing a GJ/218 Circuit Breaker (1-Pole) (Lists AC, AD, BC, BD) (cont'd on next page)

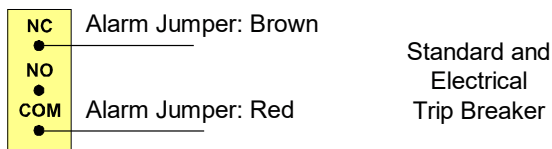
**INSTALLING CIRCUIT BREAKER**



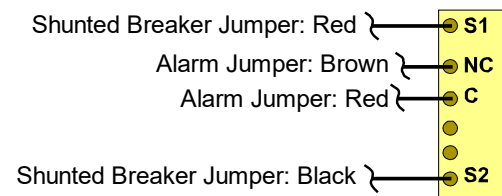
**INSTALLING CIRCUIT BREAKER GUARD**



**ALARM WIRING (BREAKERS W/OUT SHUNTS)**



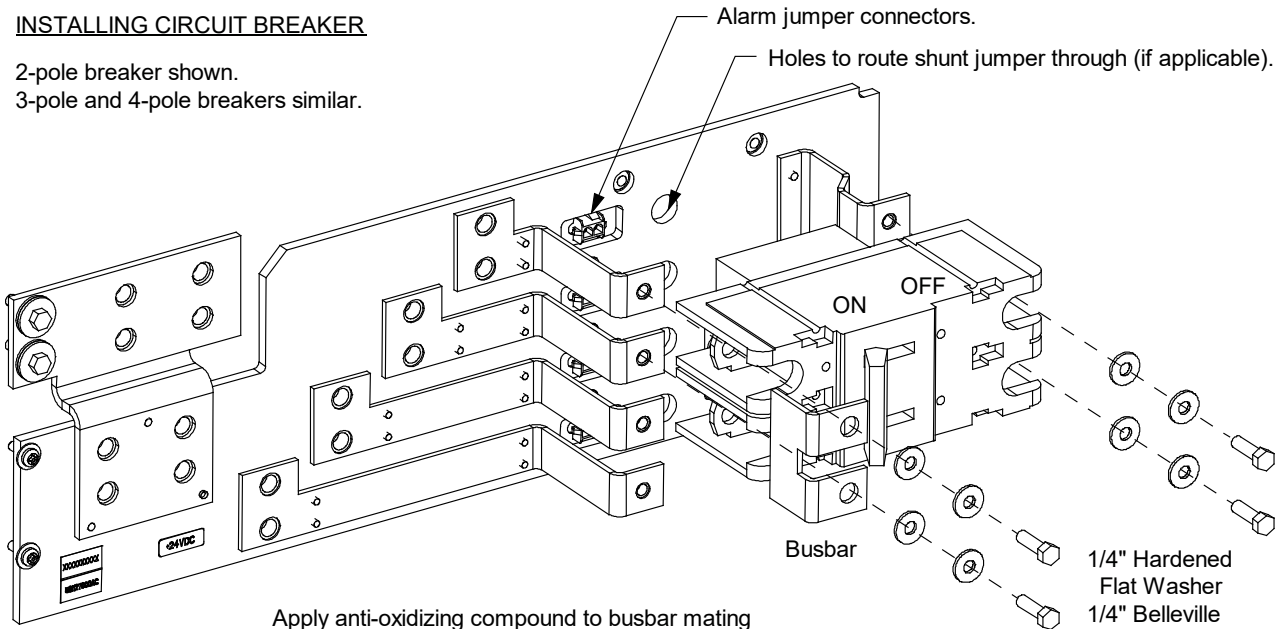
**ALARM WIRING (BREAKERS WITH SHUNTS)**



**Figure 7** Installing a GJ/218 Circuit Breaker (2-Pole, 3-Pole, 4-Pole) (Lists AC, AD, BC, BD) (cont'd from previous page, cont'd on next page)

INSTALLING CIRCUIT BREAKER

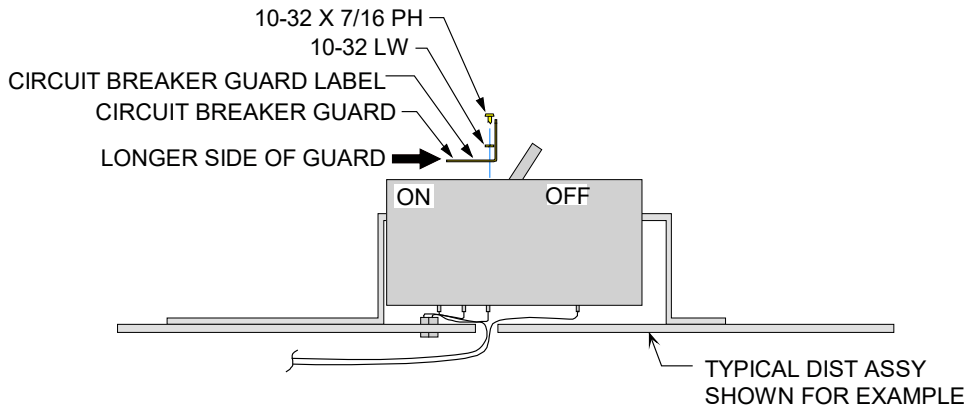
2-pole breaker shown.  
3-pole and 4-pole breakers similar.



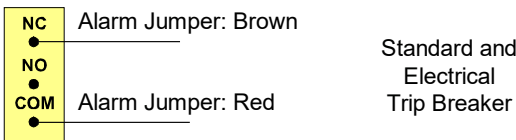
Apply anti-oxidizing compound to busbar mating surfaces before mounting circuit breakers.

- 1/4" Hardened Flat Washer
- 1/4" Belleville Lock Washer
- 1/4-20 x 3/4" Bolt
- (4 places / 2-pole brk, 6 places / 3-pole brk, 8 places / 4-pole brk)
- Torque to 60 in-lbs.

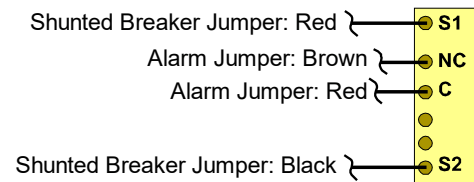
INSTALLING CIRCUIT BREAKER GUARD



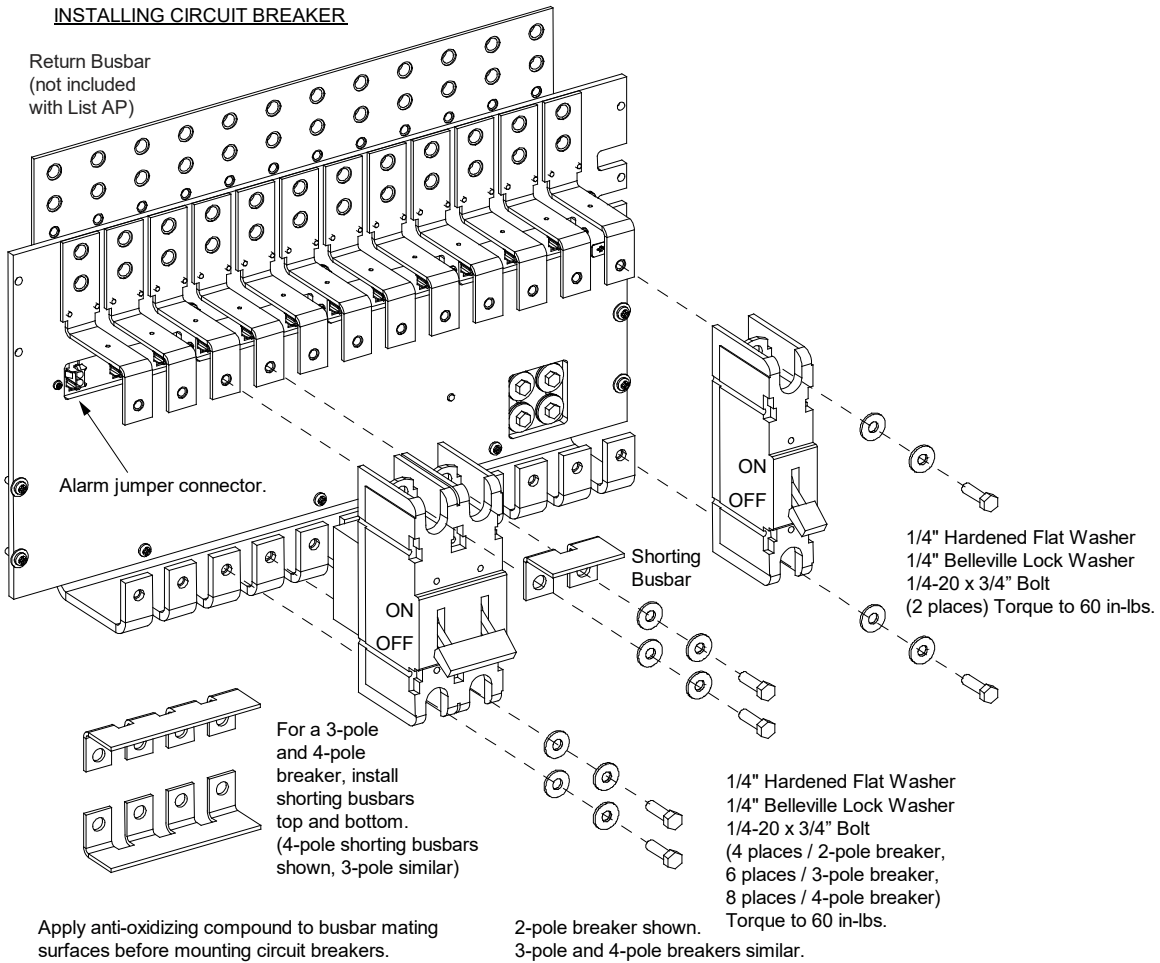
ALARM WIRING (BREAKERS W/OUT SHUNTS)



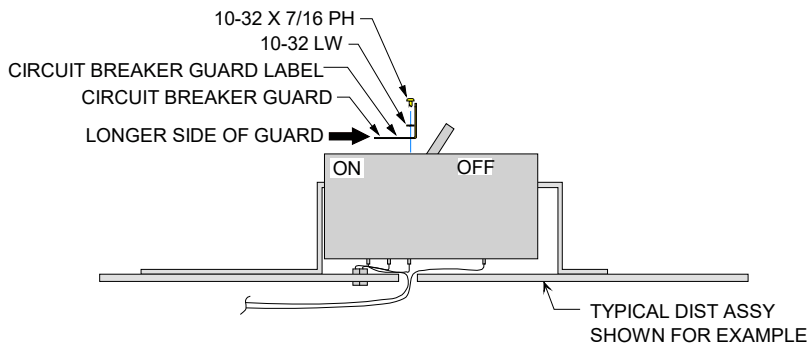
ALARM WIRING (BREAKERS WITH SHUNTS)



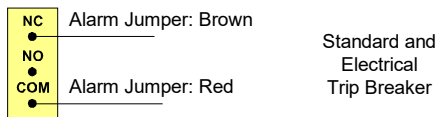
**Figure 7 Installing a GJ/218 Circuit Breaker (1-Pole, 2-Pole, 3-Pole, 4-Pole) (List AM and List AP) (cont'd from previous page)**



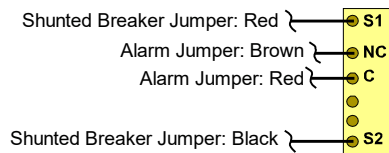
**INSTALLING CIRCUIT BREAKER GUARD**



**ALARM WIRING (BREAKERS W/OUT SHUNTS)**



**ALARM WIRING (BREAKERS WITH SHUNTS)**



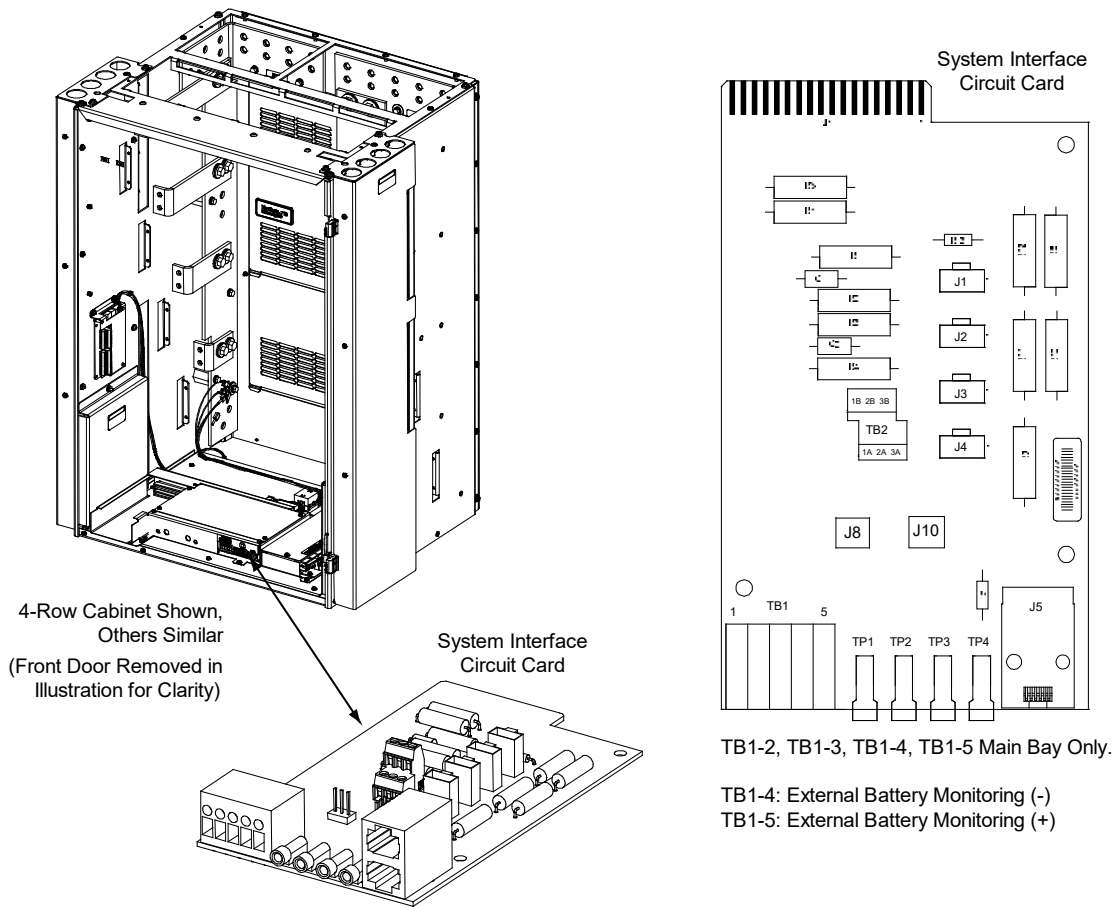
## 4 Make Jumper and Switch Settings

Various circuit cards installed in the system have switch and jumper settings.

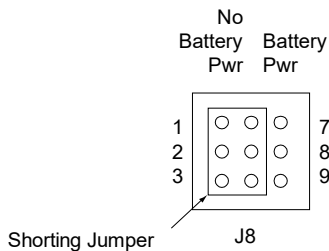
**Switch Settings:** All switch settings set the various circuit cards to operate properly with this system and have been factory set.

**Jumper Settings:** The jumpers located on the system interface circuit card are customer selectable. Refer to **Figure 8** for jumper locations and function. Refer to SETTING JUMPERS AND SWITCH OPTIONS in the Installation Instructions (IM582127000) for a complete procedure.

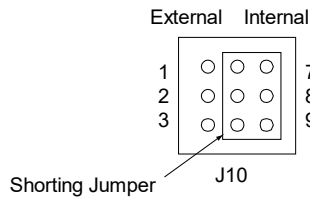
**Figure 4.1 System Interface Circuit Card Jumper Locations**



**J8 (Main Bay Only)**  
Selects to power Controller from "Battery Power" or not.



**J10 (Main Bay Only)**  
Battery Monitoring External / Internal (see TB1-4 and TB1-5 for external monitoring points)





## 5 Electrical Connections

### 5.1 Important Safety Instructions



**DANGER!** Adhere to the “Important Safety Instructions” presented at the front of this document.

To do this...	See this in the <i>Installation Instructions</i> (IM582127000)
Make Frame Grounding Connection to Relay Rack or Enclosure	<i>Relay Rack and Enclosure Grounding Connection (Frame Ground)</i> in the MAKING ELECTRICAL CONNECTIONS section.
Make Central Office Ground Connection	<i>Central Office Ground Connection</i> in the MAKING ELECTRICAL CONNECTIONS section.

### 5.2 Make Nominal 208 VAC, 240 VAC, 277 VAC, or 277 VAC / 480 VAC Input and Equipment Grounding Connections (if equipped)

Refer to “Nominal 208 VAC, 240 VAC, 277 VAC, or 277 VAC / 480 VAC Input and Equipment Grounding Connections (if equipped)” in the MAKING ELECTRICAL CONNECTIONS section of the Installation Instructions (IM582127000) for a complete procedure.

**NOTE THAT THIS SYSTEM MAY BE EQUIPPED WITH AC OR DC INPUTS. THESE PROCEDURES APPLY TO SYSTEMS WITH AC INPUTS. SPECIFICALLY, THESE PROCEDURES APPLY TO THE FOLLOWING EQUIPMENT:**

- 582127000 List 40, 41, 42, 43
- 588705000 List 21, 22, 31, 32, 33
- 588705300 List 01, 03, 21
- 588705400 List 01, 02, 03, 04
- 588705500 List 01, 02, 03, 04, 05

#### **AC Input Termination Assemblies**

The available AC input options for this system are:

- The system can be equipped with an AC input termination assembly which provides a separate single phase AC input connection for each rectifier position (582127000 List 40).
- The system can be equipped with an AC input termination assembly which provides a separate single phase AC input connection for every two (2) rectifier positions (582127000 List 41).
- The system can be equipped with an AC input termination assembly which provides a separate three phase AC input connection for every three (3) rectifier positions (582127000 List 42 and List 43).

### **Direct AC Input Connections to the Module Mounting Assemblies**

- The system can be equipped with module mounting assemblies that contain AC input terminal blocks which provide a separate single phase AC input connection for each rectifier position (588705000 List 31; 588705500 List 03).
- The system can be equipped with module mounting assemblies that contain AC input terminal blocks which provide a separate three phase AC input connection for every three (3) rectifier positions (588705000 List 32 and List 33; 588705500 List 04 and List 05).
- The system can be equipped with module mounting assemblies that contain AC input line cords (one for each rectifier module position) (588705000 List 22; 588705500 List 02).
- The system can be equipped with module mounting assemblies that contain AC input cable assemblies or AC input line cords which provide a separate single phase AC input connection for every two (2) rectifier positions (588705300 List 03).
- The system can be equipped with module mounting assemblies that contain AC input cable assemblies or AC input line cords (one for each rectifier module position) (588705400 List 02).
- The system can be equipped with module mounting assemblies that contain AC input line cords which provide a separate three phase AC input connection for every three (3) rectifier positions (588705400 List 03 and List 04).

### **Connections to AC Input Termination Assemblies (582127000 List 40, 41, 42, 43) (For System Mounted in a Relay Rack)**

Refer to **Figure 9**, **Figure 10**, **Figure 11**, or **Figure 12** as these procedures are performed.

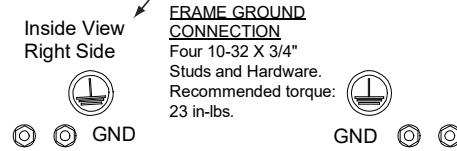
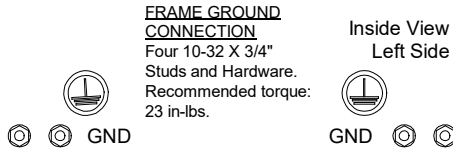
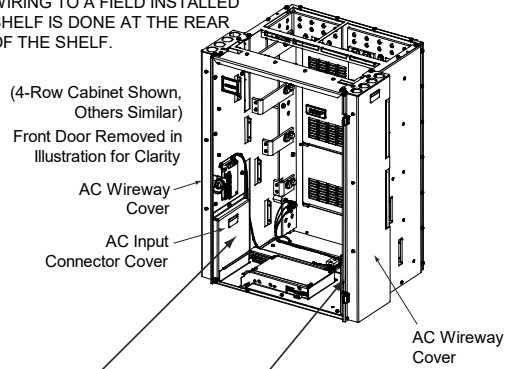
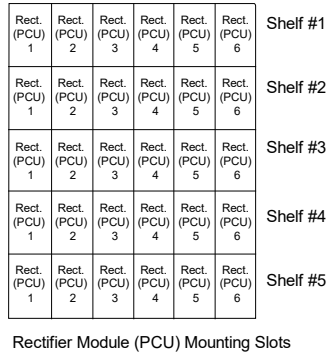


**NOTE!** Terminal blocks for a system with maximum possible rectifier shelves shown. Your system may have less terminal blocks than shown.

**Figure 5.1 AC Input Connections to AC Input Termination Assembly List 40 when Used with 588705000 (Nominal 208 VAC, 240 VAC, 277 VAC) or 588705300 (Nominal 208 VAC, 240 VAC) or 588705400 (Nominal 208 VAC, 240 VAC, 277 VAC) or 588705500 (Nominal 208 VAC, 240 VAC, 277 VAC) Module Mounting Assemblies with Rectifiers (1 Feed per 1 Rectifier, Single Phase) (Installed in a Relay Rack) (cont'd on next page)**

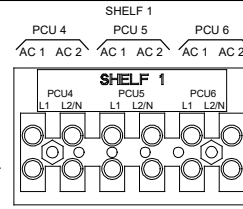
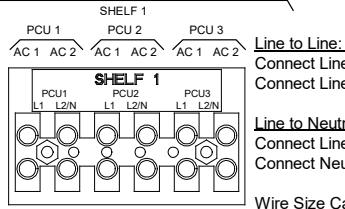
AC INPUT CONNECTIONS,  
1 FEED PER 1 RECTIFIER, SINGLE PHASE  
(582127000 LIST 40)

NOTE:  
WIRING TO A FIELD INSTALLED  
SHELF IS DONE AT THE REAR  
OF THE SHELF.



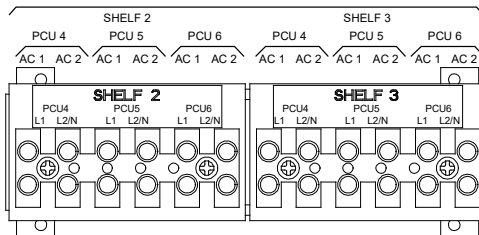
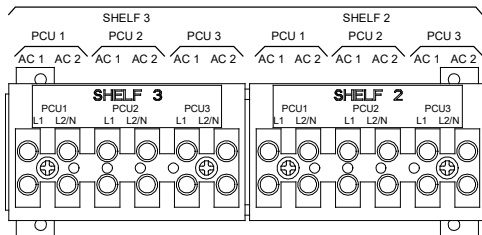
RECTIFIER (PCU) AC INPUT FEEDS  
1 FEED PER 1 RECTIFIER (PCU)  
208 VAC, 240 VAC, 277 VAC, 50 Hz / 60Hz, SINGLE PHASE

RECTIFIER (PCU) AC INPUT FEEDS  
1 FEED PER 1 RECTIFIER (PCU)  
208 VAC, 240 VAC, 277 VAC, 50 Hz / 60Hz, SINGLE PHASE



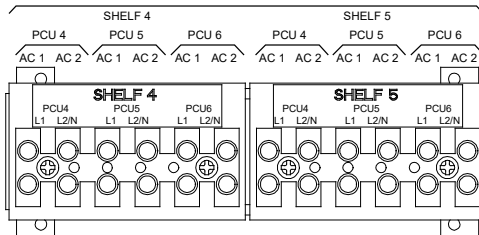
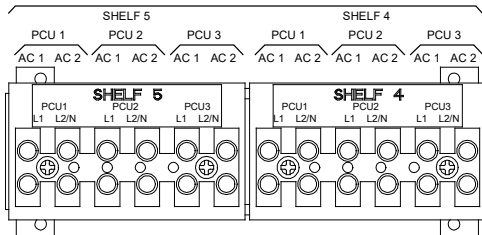
RECTIFIER (PCU) AC INPUT FEEDS  
1 FEED PER 1 RECTIFIER (PCU)  
208 VAC, 240 VAC, 277 VAC, 50 Hz / 60Hz, SINGLE PHASE

RECTIFIER (PCU) AC INPUT FEEDS  
1 FEED PER 1 RECTIFIER (PCU)  
208 VAC, 240 VAC, 277 VAC, 50 Hz / 60Hz, SINGLE PHASE



RECTIFIER (PCU) AC INPUT FEEDS  
1 FEED PER 1 RECTIFIER (PCU)  
208 VAC, 240 VAC, 277 VAC, 50 Hz / 60Hz, SINGLE PHASE

RECTIFIER (PCU) AC INPUT FEEDS  
1 FEED PER 1 RECTIFIER (PCU)  
208 VAC, 240 VAC, 277 VAC, 50 Hz / 60Hz, SINGLE PHASE

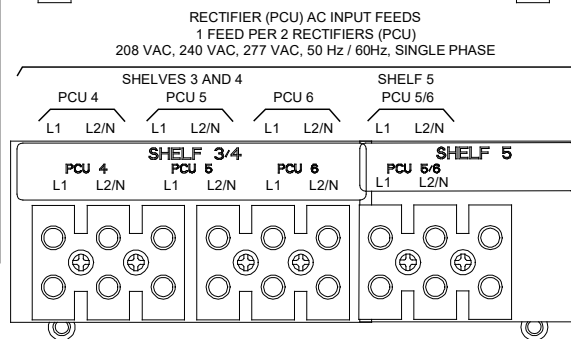
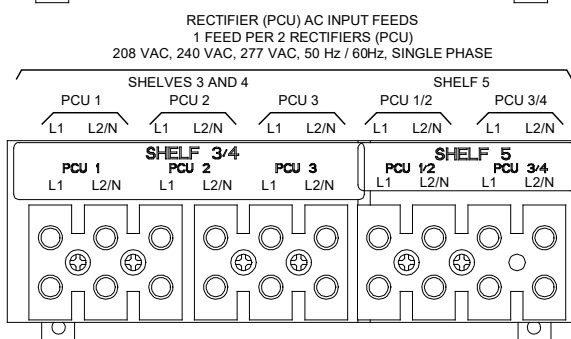
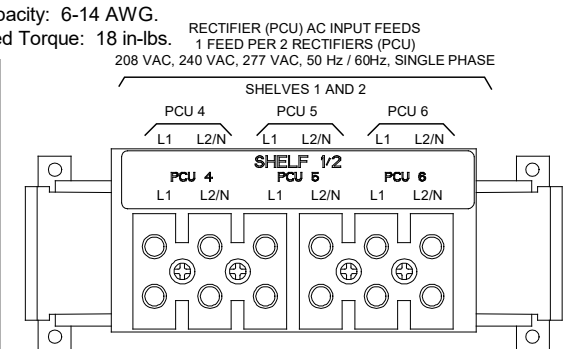
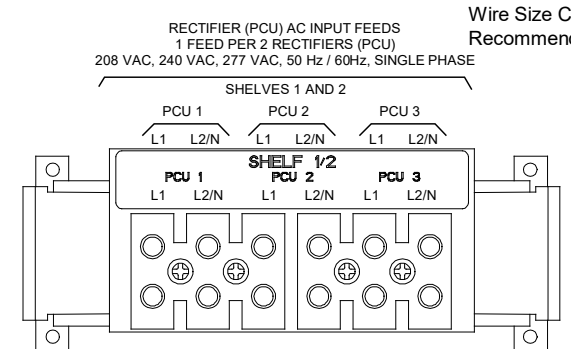
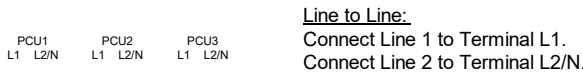
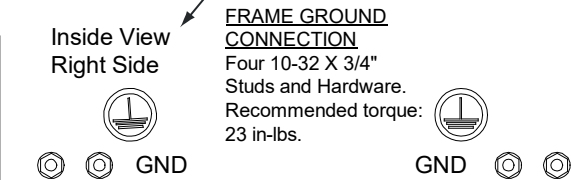
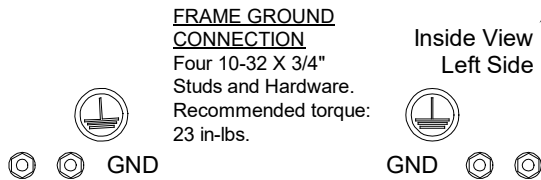
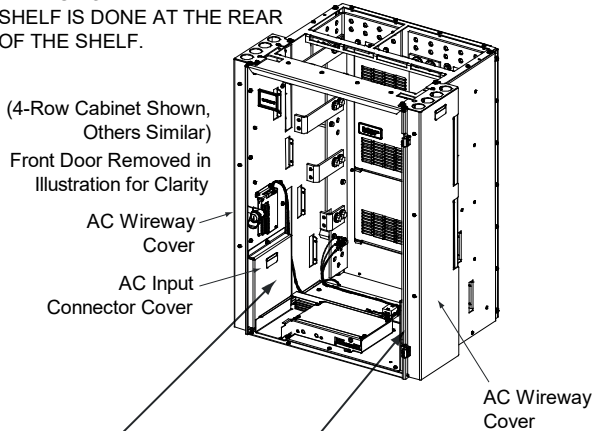
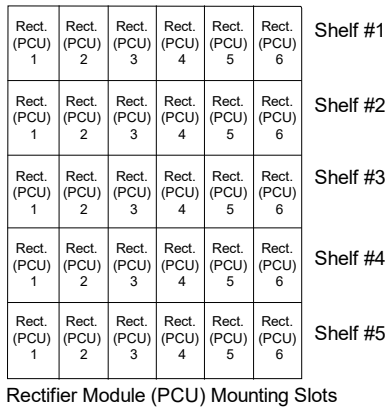


Note: For fewer power shelves than shown, only the connections for the installed shelves are present.

**Figure 5.2 AC Input Connections to AC Input Termination Assembly List 41 when used with 588705000 (Nominal 208 VAC, 240 VAC, 277 VAC) or 588705300 (Nominal 208 VAC, 240 VAC) or 588705400 (Nominal 208 VAC, 240 VAC, 277 VAC) or 588705500 (Nominal 208 VAC, 240 VAC, 277 VAC) Module Mounting Assemblies with Rectifiers (1 Feed per 2 Rectifiers, Single Phase) - with Five (5) Shelves Installed (Installed in a Relay Rack) (cont'd on next page)**

AC INPUT CONNECTIONS,  
1 FEED PER 2 RECTIFIERS, SINGLE PHASE  
(582127000 LIST 41),  
with Five (5) Shelves Installed

NOTE:  
WIRING TO A FIELD INSTALLED  
SHELF IS DONE AT THE REAR  
OF THE SHELF.



Wire Size Capacity: 6-14 AWG.  
Recommended Torque: 18 in-lbs.

**Figure 10 AC Input Connections to AC Input Termination Assembly List 41 when used with 588705000 (Nominal 208 VAC, 240 VAC, 277 VAC) or 588705300 (Nominal 208 VAC, 240 VAC) or 588705400 (Nominal 208 VAC, 240 VAC, 277 VAC) or 588705500 (Nominal 208 VAC, 240 VAC, 277 VAC) Module Mounting Assemblies with Rectifiers (1 Feed per 2 Rectifiers, Single Phase) - with Four (4) Shelves Installed (Installed in a Relay Rack) (cont'd from previous page, cont'd on next page)**

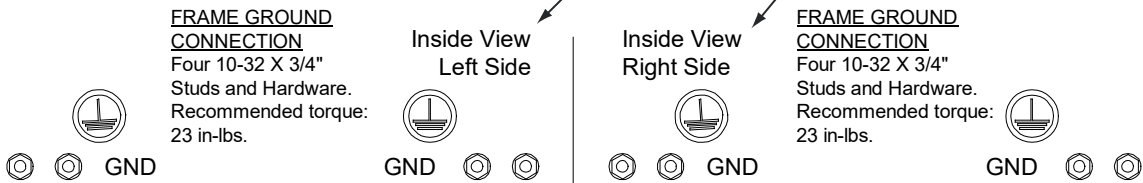
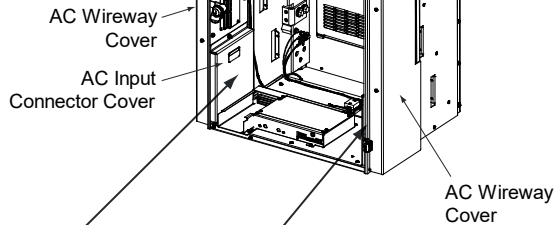
AC INPUT CONNECTIONS,  
1 FEED PER 2 RECTIFIERS, SINGLE PHASE  
(582127000 LIST 41),  
with Four (4) Shelves Installed

NOTE:  
WIRING TO A FIELD INSTALLED  
SHELF IS DONE AT THE REAR  
OF THE SHELF.

Rect. (PCU) 1	Rect. (PCU) 2	Rect. (PCU) 3	Rect. (PCU) 4	Rect. (PCU) 5	Rect. (PCU) 6	Shelf #1	
Rect. (PCU) 1	Rect. (PCU) 2	Rect. (PCU) 3	Rect. (PCU) 4	Rect. (PCU) 5	Rect. (PCU) 6		Shelf #2
Rect. (PCU) 1	Rect. (PCU) 2	Rect. (PCU) 3	Rect. (PCU) 4	Rect. (PCU) 5	Rect. (PCU) 6		Shelf #3
Rect. (PCU) 1	Rect. (PCU) 2	Rect. (PCU) 3	Rect. (PCU) 4	Rect. (PCU) 5	Rect. (PCU) 6		Shelf #4

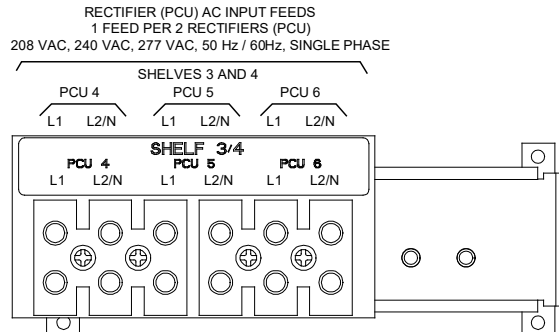
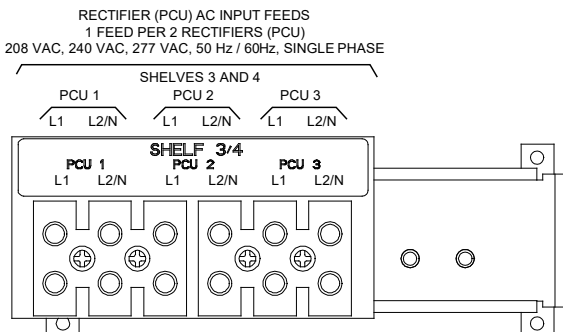
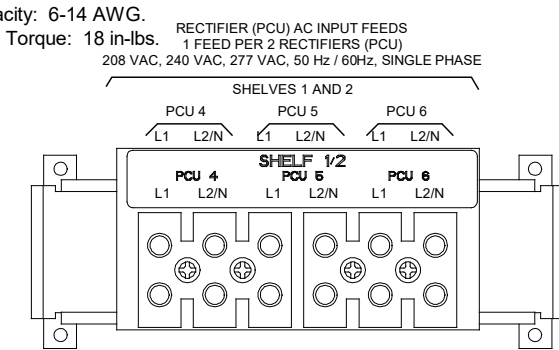
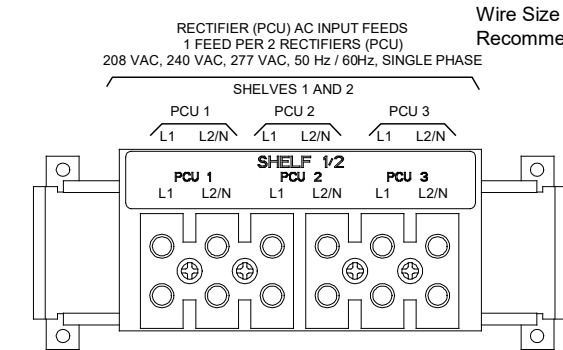
Rectifier Module (PCU) Mounting Slots

(4-Row Cabinet Shown,  
Others Similar)  
Front Door Removed in  
Illustration for Clarity



Line to Line:  
Connect Line 1 to Terminal L1.  
Connect Line 2 to Terminal L2/N.

Line to Neutral:  
Connect Line to Terminal L1.  
Connect Neutral to Terminal L2/N.



**Figure 10 AC Input Connections to AC Input Termination Assembly List 41 when used with 588705000 (Nominal 208 VAC, 240 VAC, 277 VAC) or 588705300 (Nominal 208 VAC, 240 VAC) or 588705400 (Nominal 208 VAC, 240 VAC, 277 VAC) or 588705500 (Nominal 208 VAC, 240 VAC, 277 VAC) Module Mounting Assemblies with Rectifiers (1 Feed per 2 Rectifiers, Single Phase) - with Three (3) Shelves Installed (Installed in a Relay Rack) (cont'd from previous page, cont'd on next page)**

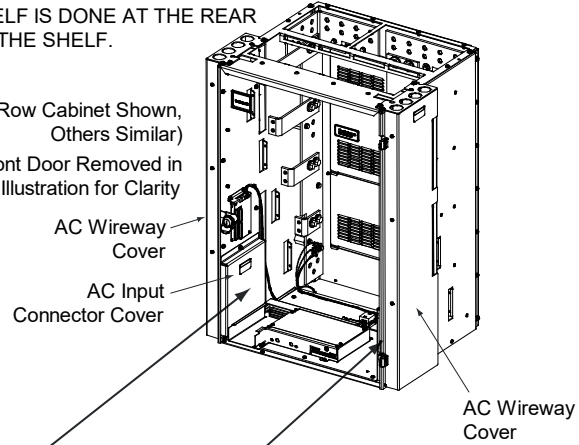
AC INPUT CONNECTIONS,  
1 FEED PER 2 RECTIFIERS, SINGLE PHASE  
(582127000 LIST 41),  
with Three (3) Shelves Installed

NOTE:  
WIRING TO A FIELD INSTALLED  
SHELF IS DONE AT THE REAR  
OF THE SHELF.

Rect. (PCU) 1	Rect. (PCU) 2	Rect. (PCU) 3	Rect. (PCU) 4	Rect. (PCU) 5	Rect. (PCU) 6	Shelf #1
Rect. (PCU) 1	Rect. (PCU) 2	Rect. (PCU) 3	Rect. (PCU) 4	Rect. (PCU) 5	Rect. (PCU) 6	
Rect. (PCU) 1	Rect. (PCU) 2	Rect. (PCU) 3	Rect. (PCU) 4	Rect. (PCU) 5	Rect. (PCU) 6	

Rectifier Module (PCU) Mounting Slots

(4-Row Cabinet Shown,  
Others Similar)  
Front Door Removed in  
Illustration for Clarity



**FRAME GROUND CONNECTION**

Four 10-32 X 3/4"  
Studs and Hardware.  
Recommended torque:  
23 in.-lbs.



**Inside View Left Side**



**Inside View Right Side**



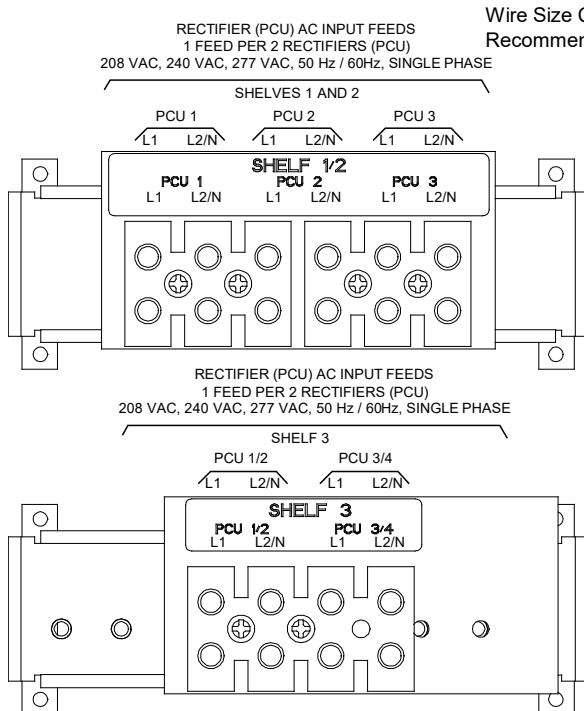
**FRAME GROUND CONNECTION**

Four 10-32 X 3/4"  
Studs and Hardware.  
Recommended torque:  
23 in.-lbs.

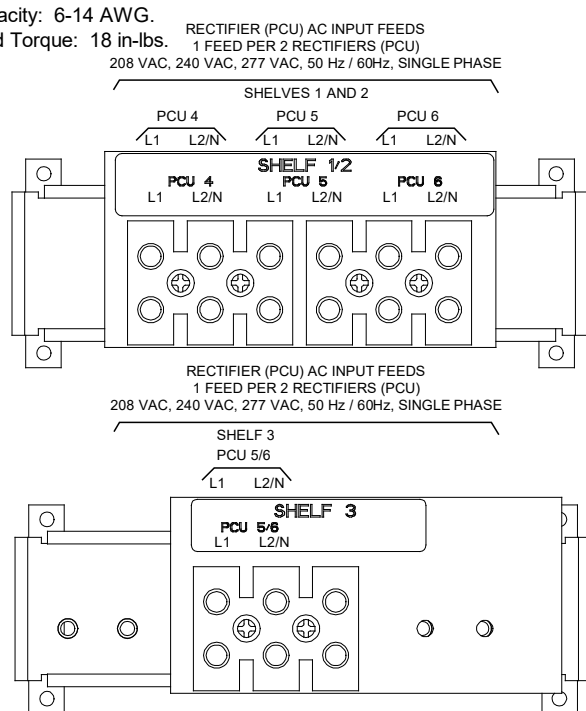


**Line to Line:**  
Connect Line 1 to Terminal L1.  
Connect Line 2 to Terminal L2/N.

**Line to Neutral:**  
Connect Line to Terminal L1.  
Connect Neutral to Terminal L2/N.



Wire Size Capacity: 6-14 AWG.  
Recommended Torque: 18 in.-lbs.



**Figure 10 AC Input Connections to AC Input Termination Assembly List 41 when used with 588705000 (Nominal 208 VAC, 240 VAC, 277 VAC) or 588705300 (Nominal 208 VAC, 240 VAC) or 588705400 (Nominal 208 VAC, 240 VAC, 277 VAC) or 588705500 (Nominal 208 VAC, 240 VAC, 277 VAC) Module Mounting Assemblies with Rectifiers (1 Feed per 2 Rectifiers, Single Phase) - with Two (2) Shelves Installed (Installed in a Relay Rack) (cont'd from previous page, cont'd on next page)**

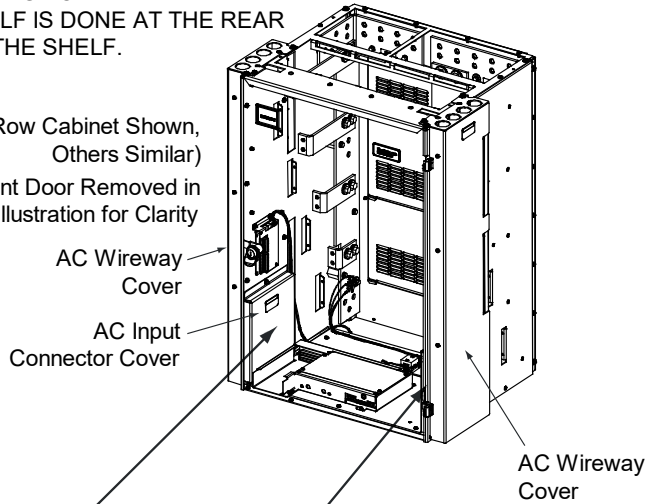
**AC INPUT CONNECTIONS,  
1 FEED PER 2 RECTIFIERS, SINGLE PHASE  
(582127000 LIST 41),  
with Two (2) Shelves Installed**

**NOTE:**  
WIRING TO A FIELD INSTALLED  
SHELF IS DONE AT THE REAR  
OF THE SHELF.

Rect. (PCU) 1	Rect. (PCU) 2	Rect. (PCU) 3	Rect. (PCU) 4	Rect. (PCU) 5	Rect. (PCU) 6	Shelf #1
Rect. (PCU) 1	Rect. (PCU) 2	Rect. (PCU) 3	Rect. (PCU) 4	Rect. (PCU) 5	Rect. (PCU) 6	

Rectifier Module (PCU) Mounting Slots

(4-Row Cabinet Shown,  
Others Similar)  
Front Door Removed in  
Illustration for Clarity

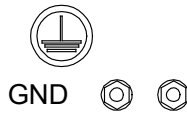


**FRAME GROUND CONNECTION**

Four 10-32 X 3/4" Studs and Hardware.  
Recommended torque: 23 in-lbs.



**Inside View Left Side**

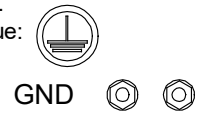


**Inside View Right Side**



**FRAME GROUND CONNECTION**

Four 10-32 X 3/4" Studs and Hardware.  
Recommended torque: 23 in-lbs.

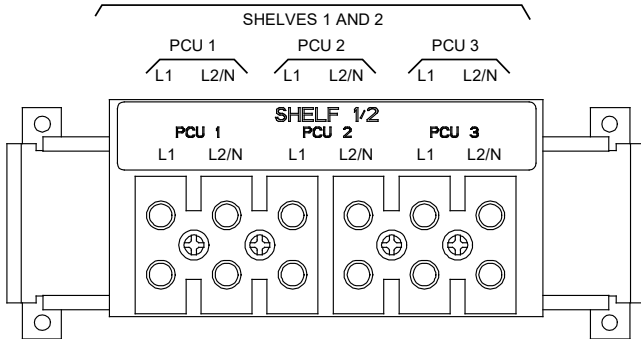


**Line to Line:**  
Connect Line 1 to Terminal L1.  
Connect Line 2 to Terminal L2/N.

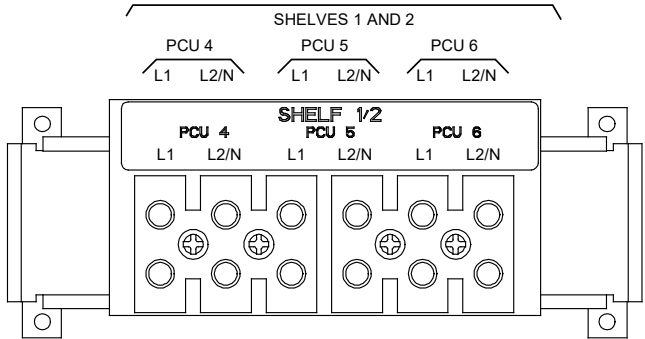
**Line to Neutral:**  
Connect Line to Terminal L1.  
Connect Neutral to Terminal L2/N.

Wire Size Capacity: 6-14 AWG.  
Recommended Torque: 18 in-lbs.

RECTIFIER (PCU) AC INPUT FEEDS  
1 FEED PER 2 RECTIFIERS (PCU)  
208 VAC, 240 VAC, 277 VAC, 50 Hz / 60Hz, SINGLE PHASE



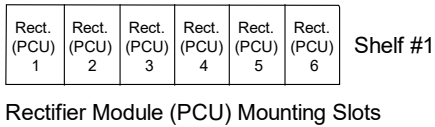
RECTIFIER (PCU) AC INPUT FEEDS  
1 FEED PER 2 RECTIFIERS (PCU)  
208 VAC, 240 VAC, 277 VAC, 50 Hz / 60Hz, SINGLE PHASE



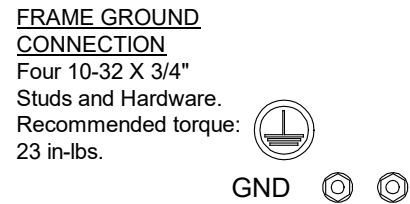
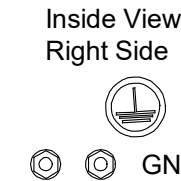
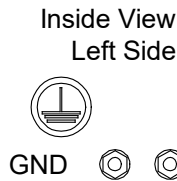
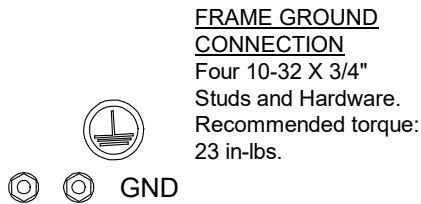
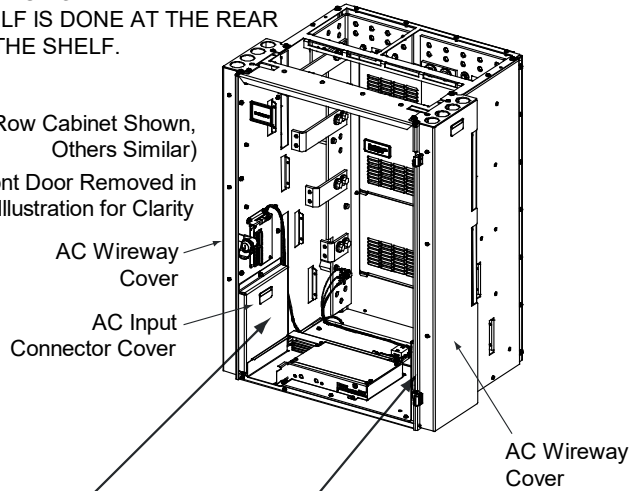
**Figure 10 AC Input Connections to AC Input Termination Assembly List 41 when used with 588705000 (Nominal 208 VAC, 240 VAC, 277 VAC) or 588705300 (Nominal 208 VAC, 240 VAC) or 588705400 (Nominal 208 VAC, 240 VAC, 277 VAC) or 588705500 (Nominal 208 VAC, 240 VAC, 277 VAC) Module Mounting Assemblies with Rectifiers (1 Feed per 2 Rectifiers, Single Phase) - with One (1) Shelf Installed (Installed in a Relay Rack) (cont'd from previous page)**

**AC INPUT CONNECTIONS,  
1 FEED PER 2 RECTIFIERS, SINGLE PHASE  
(582127000 LIST 41),  
with One (1) Shelf Installed**

**NOTE:**  
WIRING TO A FIELD INSTALLED  
SHELF IS DONE AT THE REAR  
OF THE SHELF.



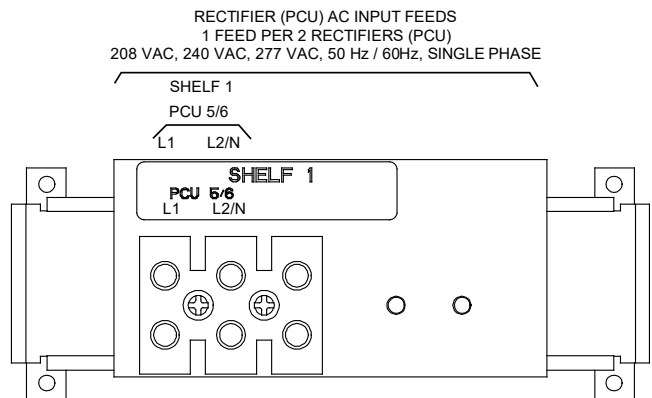
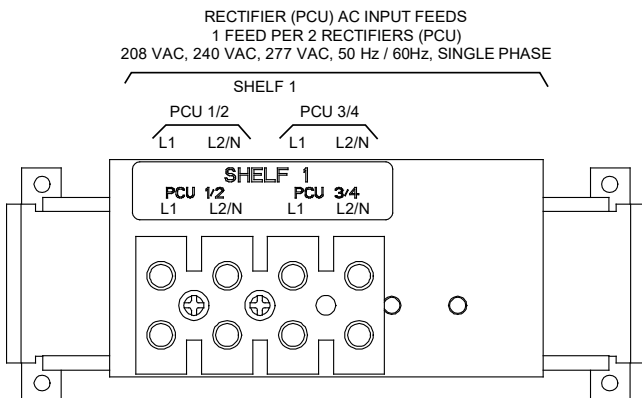
(4-Row Cabinet Shown,  
Others Similar)  
Front Door Removed in  
Illustration for Clarity



Line to Line:  
Connect Line 1 to Terminal L1.  
Connect Line 2 to Terminal L2/N.

Line to Neutral  
Connect Line to Terminal L1.  
Connect Neutral to Terminal L2/N.

Wire Size Capacity: 6-14 AWG.  
Recommended Torque: 18 in-lbs.

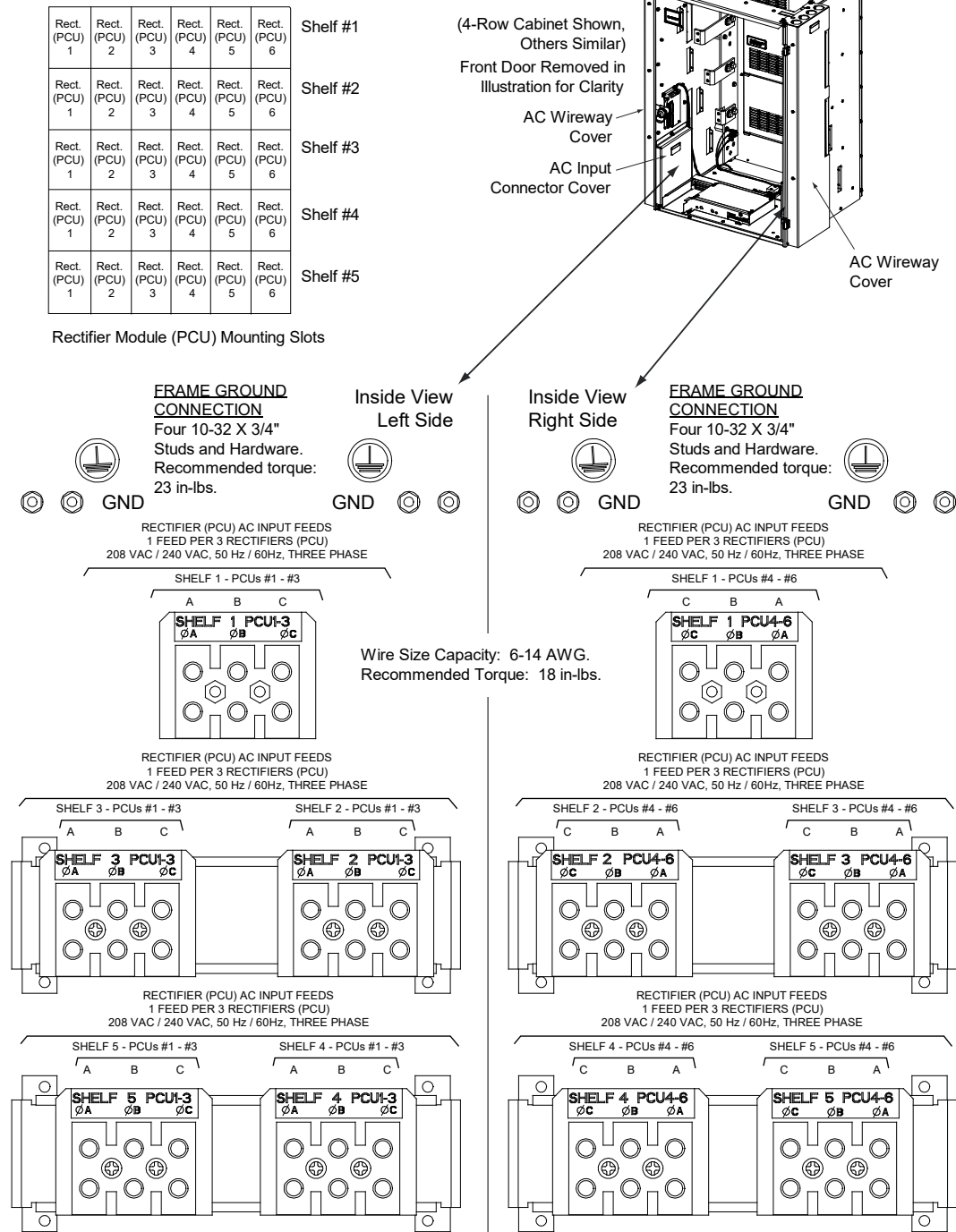




**Figure 5.3 AC Input Connections to AC Input Termination Assembly List 42 when used with 588705000 or 588705300 or 588705400 or 588705500 Module Mounting Assemblies with Rectifiers (Nominal 208 VAC, 240 VAC) (1 Feed per 3 Rectifiers, Three Phase) (Installed in a Relay Rack)**

AC INPUT CONNECTIONS,  
1 FEED PER 3 RECTIFIERS, THREE PHASE  
(582127000 LIST 42)

NOTE:  
WIRING TO A FIELD INSTALLED  
SHELF IS DONE AT THE REAR  
OF THE SHELF.



Note: For fewer power shelves than shown, only the connections for the installed shelves are present.

Note: The three-phase input is internally distributed within the system to provide a single-phase line to neutral connection to each rectifier position, evenly distributed across the three phases.

**Figure 5.4 AC Input Connections to AC Input Termination Assembly List 43 when used with 588705000 or 588705400 or 588705500 Module Mounting Assemblies with Rectifiers (Nominal 277/480 VAC) (1 Feed per 3 Rectifiers, Three Phase) (Installed in a Relay Rack)**

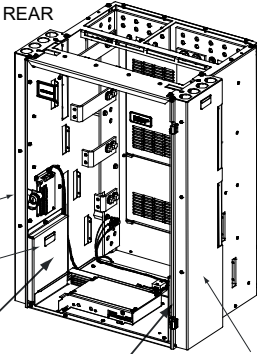
AC INPUT CONNECTIONS,  
1 FEED PER 3 RECTIFIERS, THREE PHASE  
(582127000 LIST 43)

NOTE:  
WIRING TO A FIELD INSTALLED  
SHELF IS DONE AT THE REAR  
OF THE SHELF.

Rect. (PCU) 1	Rect. (PCU) 2	Rect. (PCU) 3	Rect. (PCU) 4	Rect. (PCU) 5	Rect. (PCU) 6	Shelf #1	
Rect. (PCU) 1	Rect. (PCU) 2	Rect. (PCU) 3	Rect. (PCU) 4	Rect. (PCU) 5	Rect. (PCU) 6		Shelf #2
Rect. (PCU) 1	Rect. (PCU) 2	Rect. (PCU) 3	Rect. (PCU) 4	Rect. (PCU) 5	Rect. (PCU) 6		Shelf #3
Rect. (PCU) 1	Rect. (PCU) 2	Rect. (PCU) 3	Rect. (PCU) 4	Rect. (PCU) 5	Rect. (PCU) 6		Shelf #4
Rect. (PCU) 1	Rect. (PCU) 2	Rect. (PCU) 3	Rect. (PCU) 4	Rect. (PCU) 5	Rect. (PCU) 6		Shelf #5

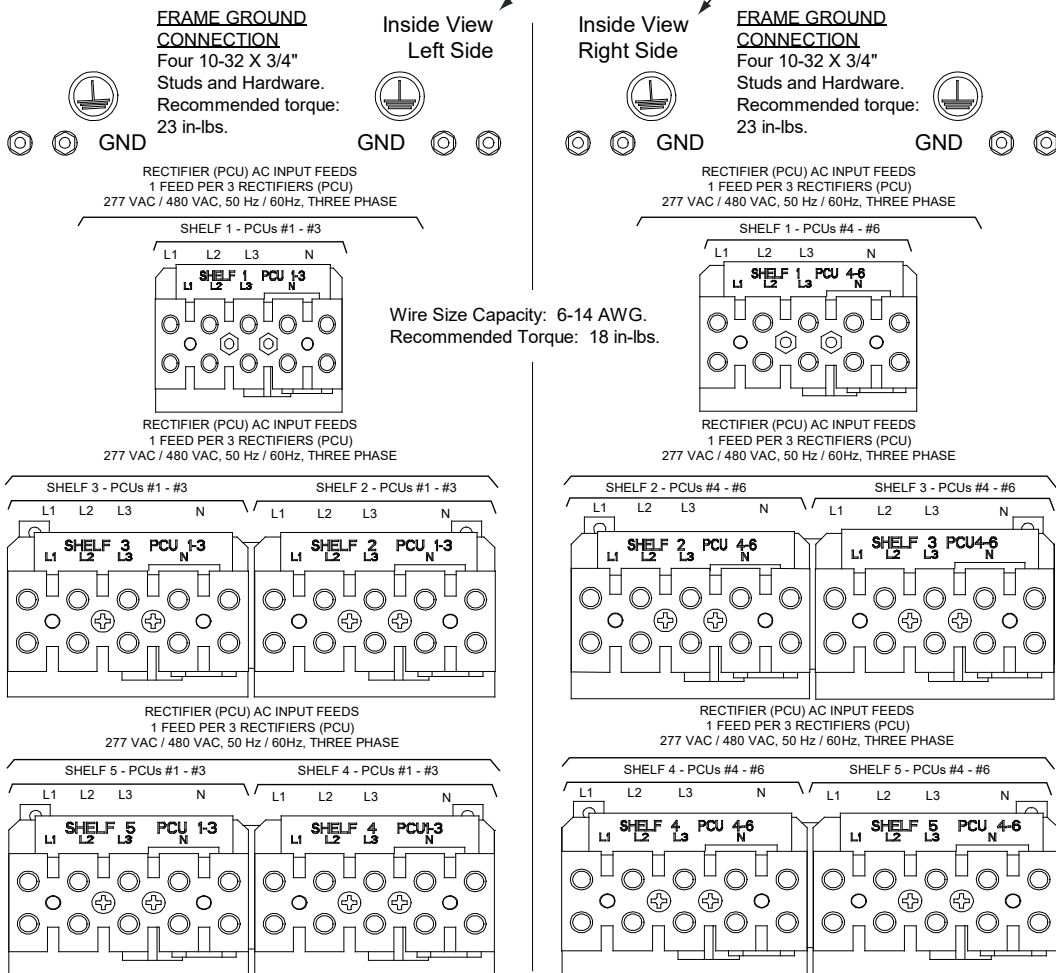
Rectifier Module (PCU) Mounting Slots

(4-Row Cabinet Shown,  
Others Similar)  
Front Door Removed in  
Illustration for Clarity



AC Wireway  
Cover  
AC Input  
Connector Cover

AC Wireway  
Cover



Note: For fewer power shelves than shown, only the connections for the installed shelves are present.  
Note: The three-phase input is internally distributed within the system to provide a single-phase line to neutral connection to each rectifier position, evenly distributed across the three phases.

### **Connections to AC Input Termination Assemblies (582127000 List 40, 41, 42, 43) (For System Mounted in an Enclosure)**

Refer to **Figure 13**, **Figure 14**, **Figure 15**, or **Figure 16** as these procedures are performed.



**NOTE!** Terminal blocks for a system with maximum possible rectifier shelves shown. Your system may have less terminal blocks than shown.

**Figure 5.5 AC Input Connections to AC Input Termination Assembly List 40 when used with 588705000 or 588705400 or 588705500 Module Mounting Assemblies with Rectifiers (Nominal 208 VAC, 240 VAC, 277 VAC) (1 Feed per 1 Rectifier, Single Phase) (Installed in an Enclosure) (cont'd on next page)**

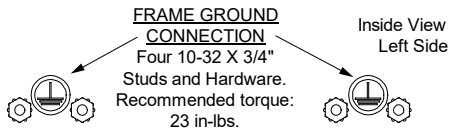
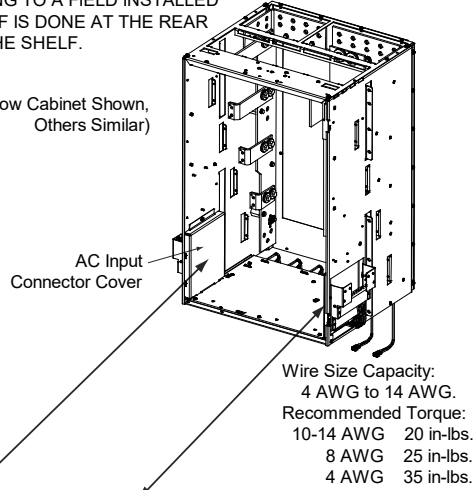
**AC INPUT CONNECTIONS,  
1 FEED PER 1 RECTIFIER, SINGLE PHASE  
(582127000 LIST 40)**

Rect. (PCU) 1	Rect. (PCU) 2	Rect. (PCU) 3	Rect. (PCU) 4	Rect. (PCU) 5	Rect. (PCU) 6	Shelf #1
Rect. (PCU) 1	Rect. (PCU) 2	Rect. (PCU) 3	Rect. (PCU) 4	Rect. (PCU) 5	Rect. (PCU) 6	Shelf #2
Rect. (PCU) 1	Rect. (PCU) 2	Rect. (PCU) 3	Rect. (PCU) 4	Rect. (PCU) 5	Rect. (PCU) 6	Shelf #3
Rect. (PCU) 1	Rect. (PCU) 2	Rect. (PCU) 3	Rect. (PCU) 4	Rect. (PCU) 5	Rect. (PCU) 6	Shelf #4
Rect. (PCU) 1	Rect. (PCU) 2	Rect. (PCU) 3	Rect. (PCU) 4	Rect. (PCU) 5	Rect. (PCU) 6	Shelf #5
Rect. (PCU) 1	Rect. (PCU) 2	Rect. (PCU) 3	Rect. (PCU) 4	Rect. (PCU) 5	Rect. (PCU) 6	Shelf #6

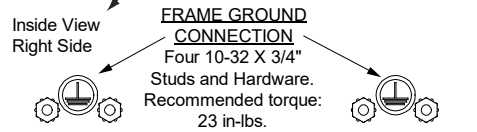
Rectifier Module (PCU) Mounting Slots

NOTE:  
WIRING TO A FIELD INSTALLED SHELF IS DONE AT THE REAR OF THE SHELF.

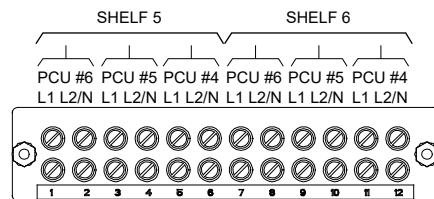
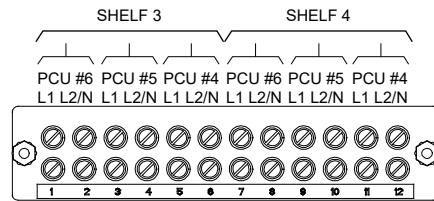
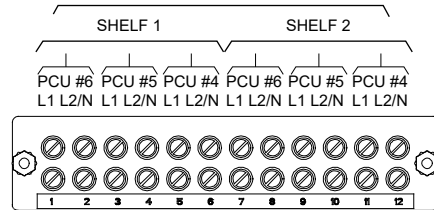
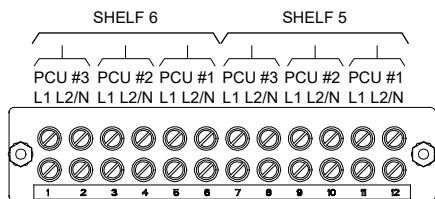
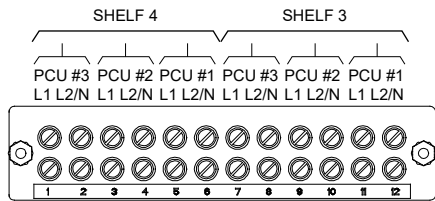
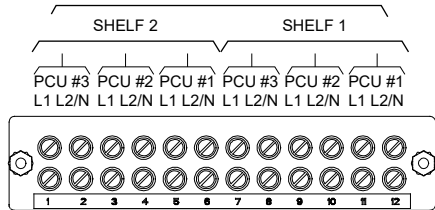
(4-Row Cabinet Shown, Others Similar)



RECTIFIER (PCU) AC INPUT FEEDS  
1 FEED PER 1 RECTIFIER (PCU)  
208 VAC, 240 VAC, 277 VAC, 50 Hz / 60 Hz, SINGLE PHASE



RECTIFIER (PCU) AC INPUT FEEDS  
1 FEED PER 1 RECTIFIER (PCU)  
208 VAC, 240 VAC, 277 VAC, 50 Hz / 60 Hz, SINGLE PHASE



Note: Customer wiring to top terminals of terminal blocks.  
For fewer power shelves than shown, only the connections for the installed shelves are present.

Line to Line:  
Connect Line 1 to Terminal L1.  
Connect Line 2 to Terminal L2/N.

Line to Neutral  
Connect Line to Terminal L1.  
Connect Neutral to Terminal L2/N.

**Figure 5.6 AC Input Connections to AC Input Termination Assembly List 41 when used with 588705000 or 588705400 or 588705500 Module Mounting Assemblies with Rectifiers (Nominal 208 VAC, 240 VAC, 277 VAC) (1 Feed per 2 Rectifiers, Single Phase) - with Six (6) Shelves Installed (Installed in an Enclosure) (cont'd on next page)**

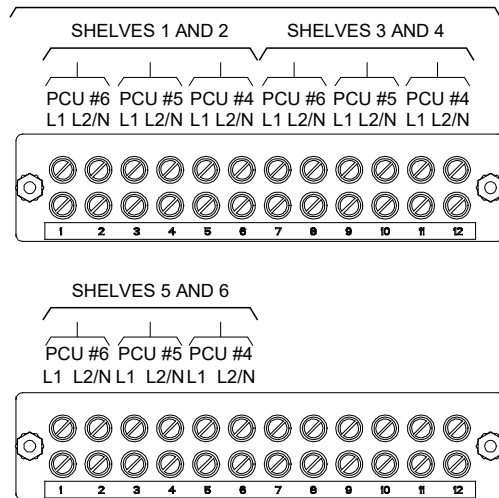
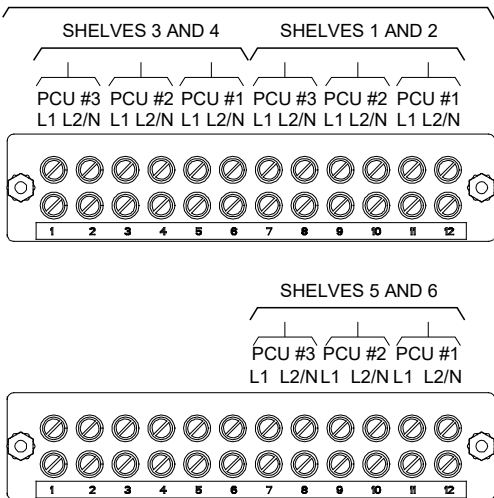
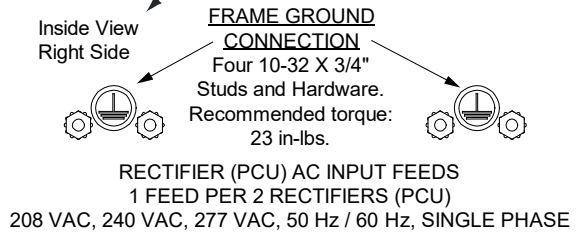
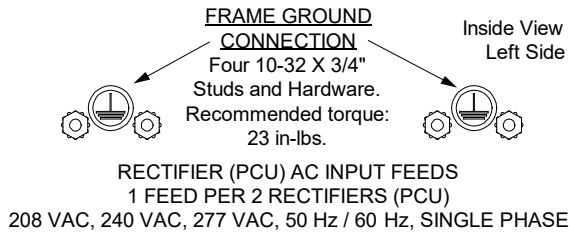
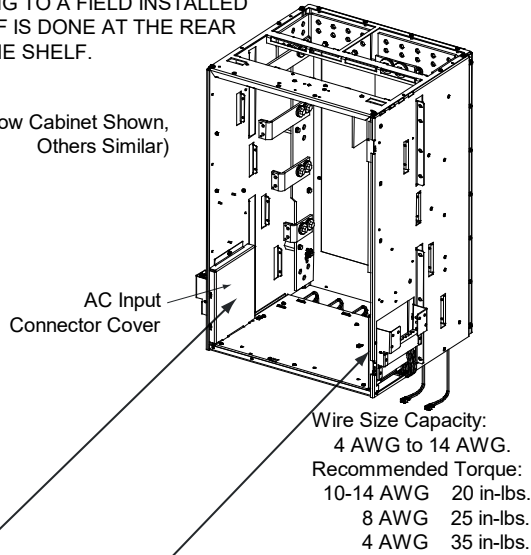
**AC INPUT CONNECTIONS,  
1 FEED PER 2 RECTIFIERS, SINGLE PHASE  
(582127000 LIST 41),  
with Six (6) Shelves Installed**

NOTE:  
WIRING TO A FIELD INSTALLED SHELF IS DONE AT THE REAR OF THE SHELF.

Rect. (PCU) 1	Rect. (PCU) 2	Rect. (PCU) 3	Rect. (PCU) 4	Rect. (PCU) 5	Rect. (PCU) 6	Shelf #1	
Rect. (PCU) 1	Rect. (PCU) 2	Rect. (PCU) 3	Rect. (PCU) 4	Rect. (PCU) 5	Rect. (PCU) 6		Shelf #2
Rect. (PCU) 1	Rect. (PCU) 2	Rect. (PCU) 3	Rect. (PCU) 4	Rect. (PCU) 5	Rect. (PCU) 6		Shelf #3
Rect. (PCU) 1	Rect. (PCU) 2	Rect. (PCU) 3	Rect. (PCU) 4	Rect. (PCU) 5	Rect. (PCU) 6		Shelf #4
Rect. (PCU) 1	Rect. (PCU) 2	Rect. (PCU) 3	Rect. (PCU) 4	Rect. (PCU) 5	Rect. (PCU) 6		Shelf #5
Rect. (PCU) 1	Rect. (PCU) 2	Rect. (PCU) 3	Rect. (PCU) 4	Rect. (PCU) 5	Rect. (PCU) 6		Shelf #6

Rectifier Module (PCU) Mounting Slots

(4-Row Cabinet Shown, Others Similar)



Note: Customer wiring to top terminals of terminal blocks.  
For fewer power shelves than shown, only the connections for the installed shelves are present.

Line to Line:  
Connect Line 1 to Terminal L1.  
Connect Line 2 to Terminal L2/N.

Line to Neutral  
Connect Line to Terminal L1.  
Connect Neutral to Terminal L2/N.

**Figure 14 AC Input Connections to AC Input Termination Assembly List 41 when used with 588705000 or 588705400 or 588705500 Module Mounting Assemblies with Rectifiers (Nominal 208 VAC, 240 VAC, 277 VAC) (1 Feed per 2 Rectifiers, Single Phase) - with Five (5) Shelves Installed (Installed in an Enclosure) (cont'd on next page)**

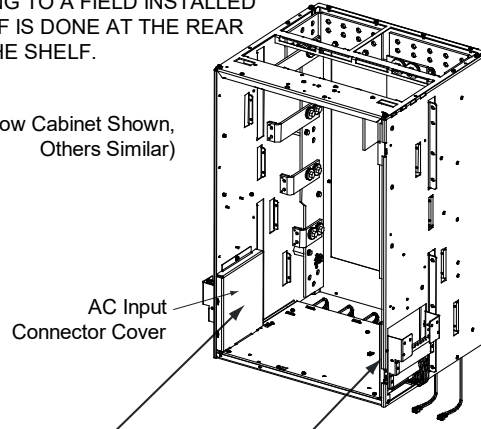
AC INPUT CONNECTIONS,  
1 FEED PER 2 RECTIFIERS, SINGLE PHASE  
(582127000 LIST 41),  
with Five (5) Shelves Installed

NOTE:  
WIRING TO A FIELD INSTALLED  
SHELF IS DONE AT THE REAR  
OF THE SHELF.

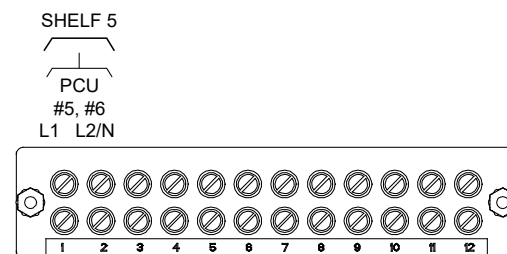
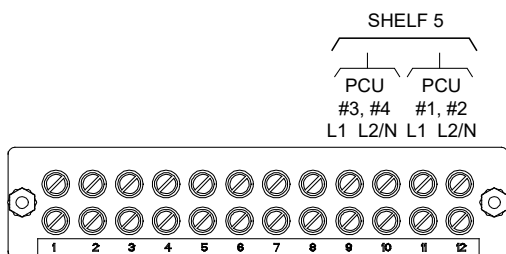
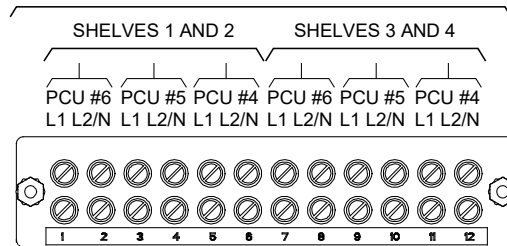
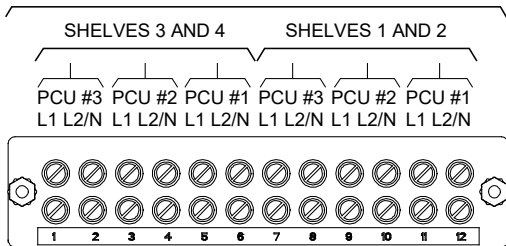
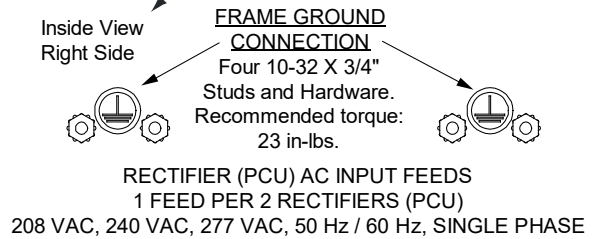
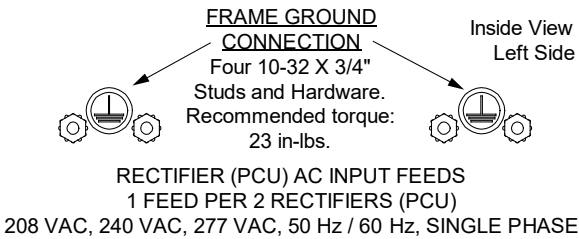
Rect. (PCU) 1	Rect. (PCU) 2	Rect. (PCU) 3	Rect. (PCU) 4	Rect. (PCU) 5	Rect. (PCU) 6	Shelf #1	
Rect. (PCU) 1	Rect. (PCU) 2	Rect. (PCU) 3	Rect. (PCU) 4	Rect. (PCU) 5	Rect. (PCU) 6		Shelf #2
Rect. (PCU) 1	Rect. (PCU) 2	Rect. (PCU) 3	Rect. (PCU) 4	Rect. (PCU) 5	Rect. (PCU) 6		Shelf #3
Rect. (PCU) 1	Rect. (PCU) 2	Rect. (PCU) 3	Rect. (PCU) 4	Rect. (PCU) 5	Rect. (PCU) 6		Shelf #4
Rect. (PCU) 1	Rect. (PCU) 2	Rect. (PCU) 3	Rect. (PCU) 4	Rect. (PCU) 5	Rect. (PCU) 6		Shelf #5

Rectifier Module (PCU) Mounting Slots

(4-Row Cabinet Shown, Others Similar)



Wire Size Capacity:  
4 AWG to 14 AWG.  
Recommended Torque:  
10-14 AWG 20 in-lbs.  
8 AWG 25 in-lbs.  
4 AWG 35 in-lbs.



Note: Customer wiring to top terminals of terminal blocks.  
For fewer power shelves than shown, only the connections for the installed shelves are present.

**Line to Line:**  
Connect Line 1 to Terminal L1.  
Connect Line 2 to Terminal L2/N.

**Line to Neutral**  
Connect Line to Terminal L1.  
Connect Neutral to Terminal L2/N.

**Figure 14 AC Input Connections to AC Input Termination Assembly List 41 when used with 588705000 or 588705400 or 588705500 Module Mounting Assemblies with Rectifiers (Nominal 208 VAC, 240 VAC, 277 VAC) (1 Feed per 2 Rectifiers, Single Phase) - with Four (4) Shelves Installed (Installed in an Enclosure) (cont'd from previous page, cont'd on next page)**

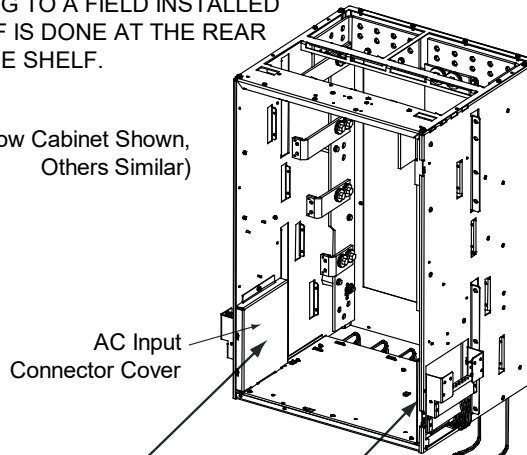
**AC INPUT CONNECTIONS,  
1 FEED PER 2 RECTIFIERS, SINGLE PHASE  
(582127000 LIST 41),  
with Four (4) Shelves Installed**

**NOTE:**  
WIRING TO A FIELD INSTALLED  
SHELF IS DONE AT THE REAR  
OF THE SHELF.

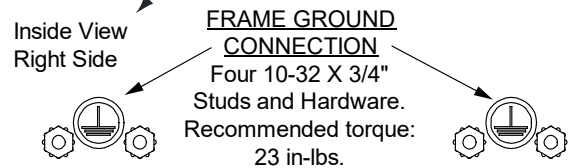
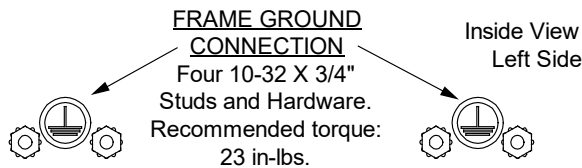
Rect. (PCU) 1	Rect. (PCU) 2	Rect. (PCU) 3	Rect. (PCU) 4	Rect. (PCU) 5	Rect. (PCU) 6	Shelf #1	
Rect. (PCU) 1	Rect. (PCU) 2	Rect. (PCU) 3	Rect. (PCU) 4	Rect. (PCU) 5	Rect. (PCU) 6		Shelf #2
Rect. (PCU) 1	Rect. (PCU) 2	Rect. (PCU) 3	Rect. (PCU) 4	Rect. (PCU) 5	Rect. (PCU) 6		Shelf #3
Rect. (PCU) 1	Rect. (PCU) 2	Rect. (PCU) 3	Rect. (PCU) 4	Rect. (PCU) 5	Rect. (PCU) 6		Shelf #4

Rectifier Module (PCU) Mounting Slots

(4-Row Cabinet Shown,  
Others Similar)

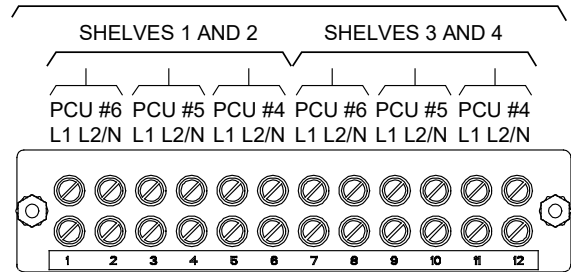
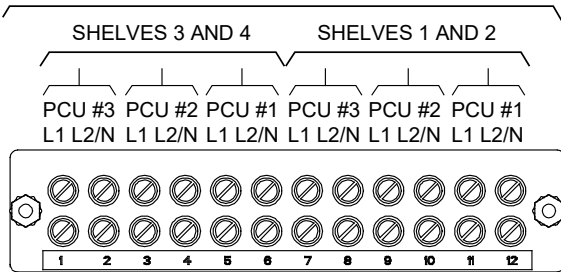


Wire Size Capacity:  
4 AWG to 14 AWG.  
Recommended Torque:  
10-14 AWG 20 in-lbs.  
8 AWG 25 in-lbs.  
4 AWG 35 in-lbs.



**RECTIFIER (PCU) AC INPUT FEEDS**  
1 FEED PER 2 RECTIFIERS (PCU)  
208 VAC, 240 VAC, 277 VAC, 50 Hz / 60 Hz, SINGLE PHASE

**RECTIFIER (PCU) AC INPUT FEEDS**  
1 FEED PER 2 RECTIFIERS (PCU)  
208 VAC, 240 VAC, 277 VAC, 50 Hz / 60 Hz, SINGLE PHASE



Note: Customer wiring to top terminals of terminal blocks.  
For fewer power shelves than shown, only the connections for the installed shelves are present.

Line to Line:  
Connect Line 1 to Terminal L1.  
Connect Line 2 to Terminal L2/N.

Line to Neutral:  
Connect Line to Terminal L1.  
Connect Neutral to Terminal L2/N.

**Figure 14 AC Input Connections to AC Input Termination Assembly List 41 when used with 588705000 or 588705400 or 588705500 Module Mounting Assemblies with Rectifiers (Nominal 208 VAC, 240 VAC, 277 VAC) (1 Feed per 2 Rectifiers, Single Phase) - with Three (3) Shelves Installed (Installed in an Enclosure) (cont'd from previous page, cont'd on next page)**

**AC INPUT CONNECTIONS,  
1 FEED PER 2 RECTIFIERS, SINGLE PHASE  
(582127000 LIST 41),  
with Three (3) Shelves Installed**

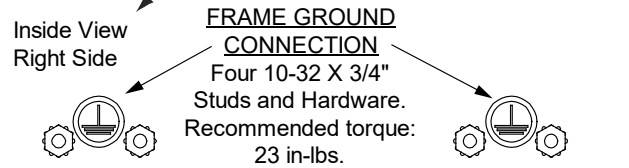
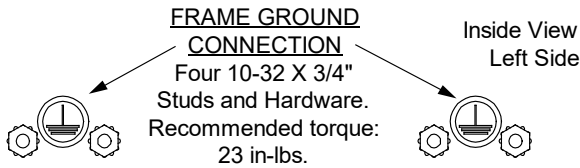
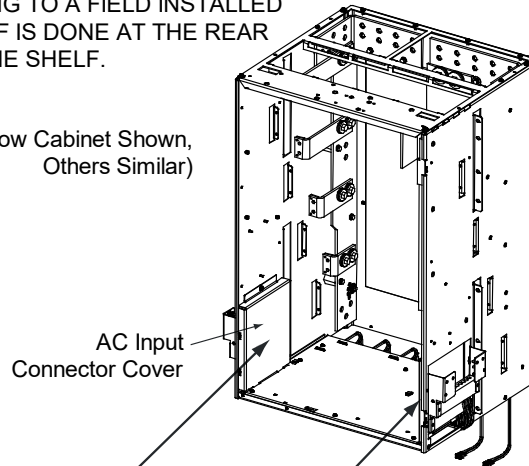
Rect. (PCU) 1	Rect. (PCU) 2	Rect. (PCU) 3	Rect. (PCU) 4	Rect. (PCU) 5	Rect. (PCU) 6	Shelf #1	
Rect. (PCU) 1	Rect. (PCU) 2	Rect. (PCU) 3	Rect. (PCU) 4	Rect. (PCU) 5	Rect. (PCU) 6		Shelf #2
Rect. (PCU) 1	Rect. (PCU) 2	Rect. (PCU) 3	Rect. (PCU) 4	Rect. (PCU) 5	Rect. (PCU) 6		Shelf #3

Rectifier Module (PCU) Mounting Slots

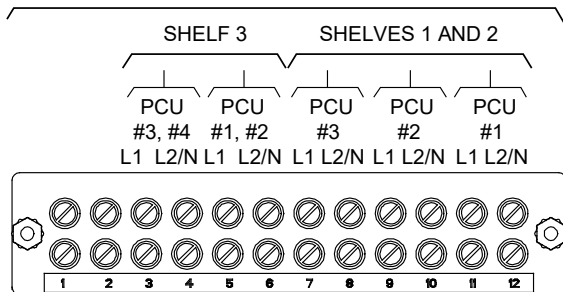
Wire Size Capacity:  
4 AWG to 14 AWG.  
Recommended Torque:  
10-14 AWG 20 in.-lbs.  
8 AWG 25 in.-lbs.  
4 AWG 35 in.-lbs.

NOTE:  
WIRING TO A FIELD INSTALLED SHELF IS DONE AT THE REAR OF THE SHELF.

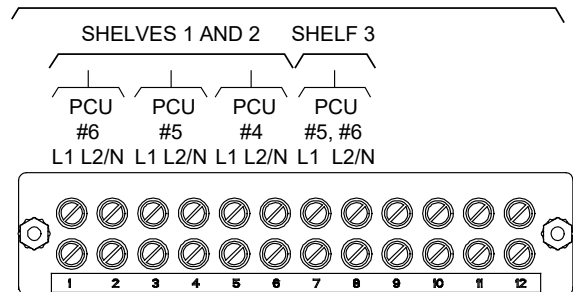
(4-Row Cabinet Shown, Others Similar)



**RECTIFIER (PCU) AC INPUT FEEDS**  
1 FEED PER 2 RECTIFIERS (PCU)  
208 VAC, 240 VAC, 277 VAC, 50 Hz / 60 Hz, SINGLE PHASE



**RECTIFIER (PCU) AC INPUT FEEDS**  
1 FEED PER 2 RECTIFIERS (PCU)  
208 VAC, 240 VAC, 277 VAC, 50 Hz / 60 Hz, SINGLE PHASE



Note: Customer wiring to top terminals of terminal blocks.  
For fewer power shelves than shown, only the connections for the installed shelves are present.

Line to Line:  
Connect Line 1 to Terminal L1.  
Connect Line 2 to Terminal L2/N.

Line to Neutral:  
Connect Line to Terminal L1.  
Connect Neutral to Terminal L2/N.



**Figure 14 AC Input Connections to AC Input Termination Assembly List 41 when used with 588705000 or 588705400 or 588705500 Module Mounting Assemblies with Rectifiers (Nominal 208 VAC, 240 VAC, 277 VAC) (1 Feed per 2 Rectifiers, Single Phase) - with Two (2) Shelves Installed (Installed in an Enclosure) (cont'd from previous page, cont'd on next page)**

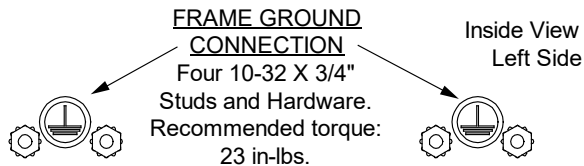
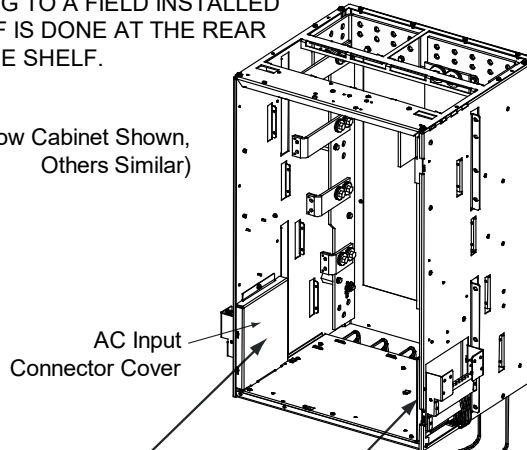
**AC INPUT CONNECTIONS,  
1 FEED PER 2 RECTIFIERS, SINGLE PHASE  
(582127000 LIST 41),  
with Two (2) Shelves Installed**

**NOTE:**  
WIRING TO A FIELD INSTALLED  
SHELF IS DONE AT THE REAR  
OF THE SHELF.

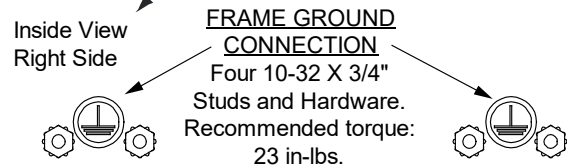
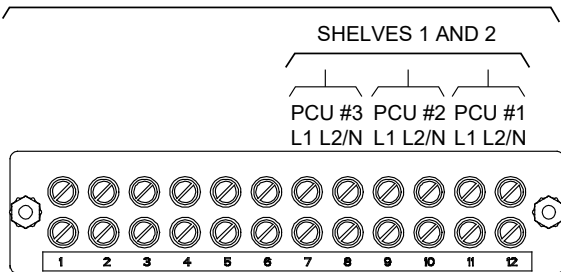
Rect. (PCU) 1	Rect. (PCU) 2	Rect. (PCU) 3	Rect. (PCU) 4	Rect. (PCU) 5	Rect. (PCU) 6	Shelf #1
Rect. (PCU) 1	Rect. (PCU) 2	Rect. (PCU) 3	Rect. (PCU) 4	Rect. (PCU) 5	Rect. (PCU) 6	
						Shelf #2

Rectifier Module (PCU) Mounting Slots

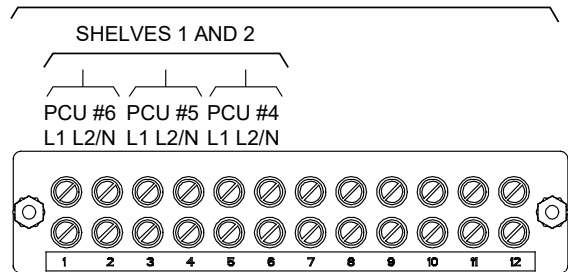
Wire Size Capacity:  
4 AWG to 14 AWG.  
Recommended Torque:  
10-14 AWG 20 in-lbs.  
8 AWG 25 in-lbs.  
4 AWG 35 in-lbs.



RECTIFIER (PCU) AC INPUT FEEDS  
1 FEED PER 2 RECTIFIERS (PCU)  
208 VAC, 240 VAC, 277 VAC, 50 Hz / 60 Hz, SINGLE PHASE



RECTIFIER (PCU) AC INPUT FEEDS  
1 FEED PER 2 RECTIFIERS (PCU)  
208 VAC, 240 VAC, 277 VAC, 50 Hz / 60 Hz, SINGLE PHASE



Note: Customer wiring to top terminals of terminal blocks.  
For fewer power shelves than shown, only the connections for the installed shelves are present.

Line to Line:  
Connect Line 1 to Terminal L1.  
Connect Line 2 to Terminal L2/N.

Line to Neutral:  
Connect Line to Terminal L1.  
Connect Neutral to Terminal L2/N.

**Figure 14 AC Input Connections to AC Input Termination Assembly List 41 when used with 588705000 or 588705400 or 588705500 Module Mounting Assemblies with Rectifiers (Nominal 208 VAC, 240 VAC, 277 VAC) (1 Feed per 2 Rectifiers, Single Phase) - with One (1) Shelf Installed (Installed in an Enclosure) (cont'd from previous page)**

**AC INPUT CONNECTIONS,  
1 FEED PER 2 RECTIFIERS, SINGLE PHASE  
(582127000 LIST 41),  
with One (1) Shelf Installed**

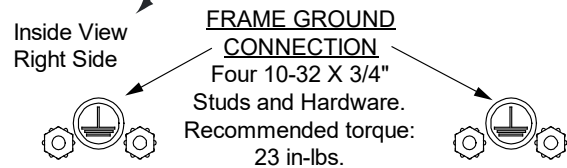
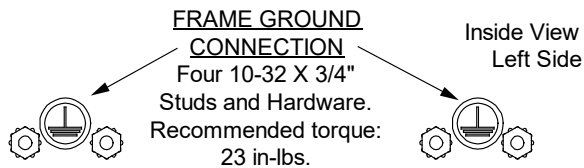
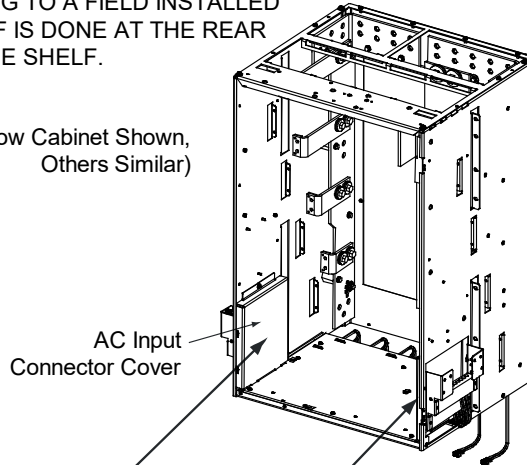
**NOTE:**  
WIRING TO A FIELD INSTALLED  
SHELF IS DONE AT THE REAR  
OF THE SHELF.

Rect. (PCU) 1	Rect. (PCU) 2	Rect. (PCU) 3	Rect. (PCU) 4	Rect. (PCU) 5	Rect. (PCU) 6	Shelf #1

Rectifier Module (PCU) Mounting Slots

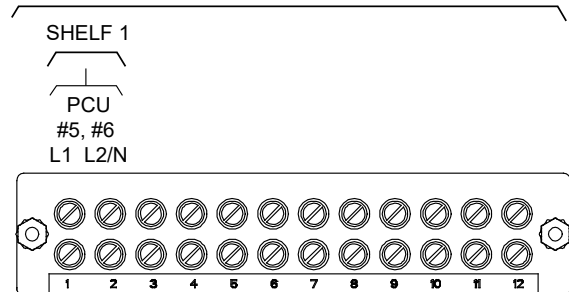
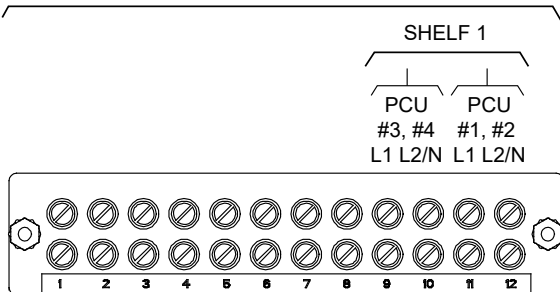
Wire Size Capacity:  
4 AWG to 14 AWG.  
Recommended Torque:  
10-14 AWG 20 in.-lbs.  
8 AWG 25 in.-lbs.  
4 AWG 35 in.-lbs.

(4-Row Cabinet Shown,  
Others Similar)



**RECTIFIER (PCU) AC INPUT FEEDS  
1 FEED PER 2 RECTIFIERS (PCU)  
208 VAC, 240 VAC, 277 VAC, 50 Hz / 60 Hz, SINGLE PHASE**

**RECTIFIER (PCU) AC INPUT FEEDS  
1 FEED PER 2 RECTIFIERS (PCU)  
208 VAC, 240 VAC, 277 VAC, 50 Hz / 60 Hz, SINGLE PHASE**



Note: Customer wiring to top terminals of terminal blocks.  
For fewer power shelves than shown, only the connections for the installed shelves are present.

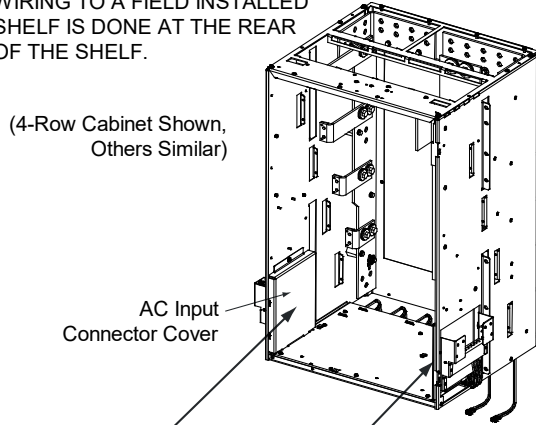
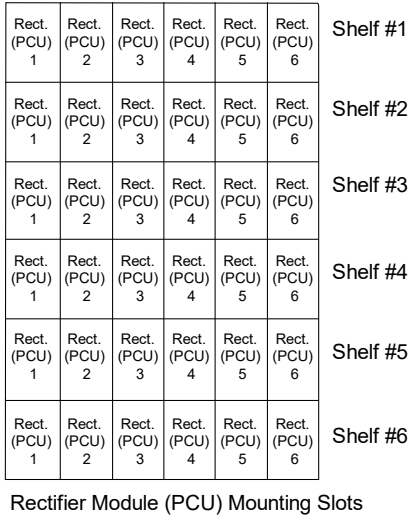
**Line to Line:**  
Connect Line 1 to Terminal L1.  
Connect Line 2 to Terminal L2/N.

**Line to Neutral**  
Connect Line to Terminal L1.  
Connect Neutral to Terminal L2/N.

**Figure 5.7 AC Input Connections to AC Input Termination Assembly List 42 when used with 588705000 or 588705400 or 588705500 Module Mounting Assemblies with Rectifiers (Nominal 208 VAC, 240 VAC) (1 Feed per 3 Rectifiers, Three Phase) (Installed in an Enclosure)**

**AC INPUT CONNECTIONS,  
1 FEED PER 3 RECTIFIERS, THREE PHASE  
(582127000 LIST 42)**

**NOTE:**  
WIRING TO A FIELD INSTALLED SHELF IS DONE AT THE REAR OF THE SHELF.

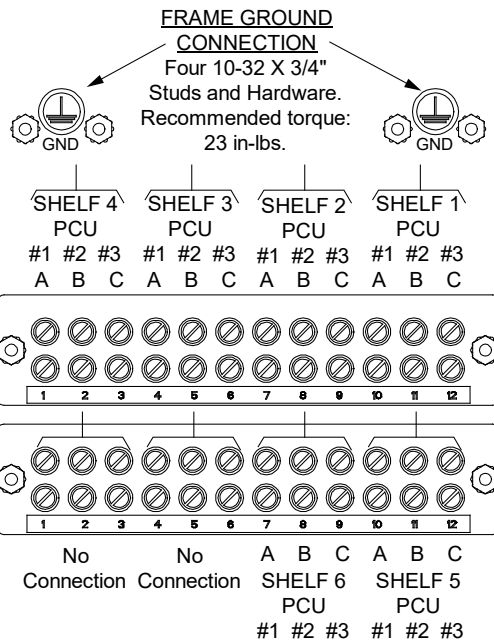


Wire Size Capacity:  
4 AWG to 14 AWG.  
Recommended Torque:  
10-14 AWG 20 in-lbs.  
8 AWG 25 in-lbs.  
4 AWG 35 in-lbs.

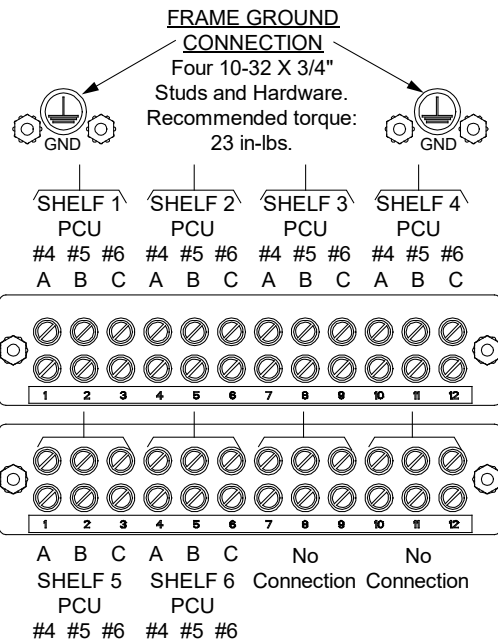
Inside View  
Left Side

Inside View  
Right Side

**RECTIFIER (PCU) AC INPUT FEEDS  
1 FEED PER 3 RECTIFIERS (PCU)  
208 VAC / 240 VAC, 50 Hz / 60 Hz, THREE PHASE**



**RECTIFIER (PCU) AC INPUT FEEDS  
1 FEED PER 3 RECTIFIERS (PCU)  
208 VAC / 240 VAC, 50 Hz / 60 Hz, THREE PHASE**



Note: Customer wiring to top terminals of terminal blocks.

For fewer power shelves than shown, only the connections for the installed shelves are present.

Note: The three-phase input is internally distributed within the system to provide a single-phase line to neutral connection to each rectifier position, evenly distributed across the three phases.

**Figure 5.8 AC Input Connections to AC Input Termination Assembly List 43 when used with 588705000 or 588705400 or 588705500 Module Mounting Assemblies with Rectifiers (Nominal 277/480 VAC) (1 Feed per 3 Rectifiers, Three Phase) (Installed in an Enclosure)**

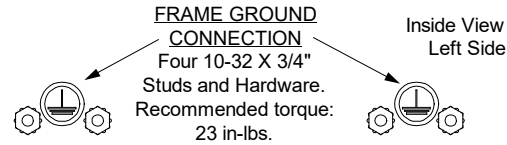
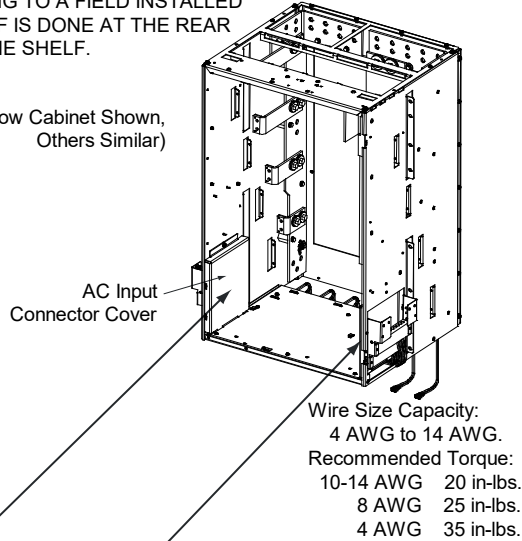
**AC INPUT CONNECTIONS,  
1 FEED PER 3 RECTIFIERS, THREE PHASE  
(582127000 LIST 43)**

Rect. (PCU) 1	Rect. (PCU) 2	Rect. (PCU) 3	Rect. (PCU) 4	Rect. (PCU) 5	Rect. (PCU) 6	Shelf #1
Rect. (PCU) 1	Rect. (PCU) 2	Rect. (PCU) 3	Rect. (PCU) 4	Rect. (PCU) 5	Rect. (PCU) 6	Shelf #2
Rect. (PCU) 1	Rect. (PCU) 2	Rect. (PCU) 3	Rect. (PCU) 4	Rect. (PCU) 5	Rect. (PCU) 6	Shelf #3
Rect. (PCU) 1	Rect. (PCU) 2	Rect. (PCU) 3	Rect. (PCU) 4	Rect. (PCU) 5	Rect. (PCU) 6	Shelf #4
Rect. (PCU) 1	Rect. (PCU) 2	Rect. (PCU) 3	Rect. (PCU) 4	Rect. (PCU) 5	Rect. (PCU) 6	Shelf #5
Rect. (PCU) 1	Rect. (PCU) 2	Rect. (PCU) 3	Rect. (PCU) 4	Rect. (PCU) 5	Rect. (PCU) 6	Shelf #6

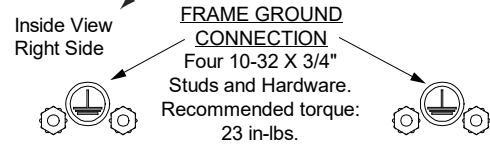
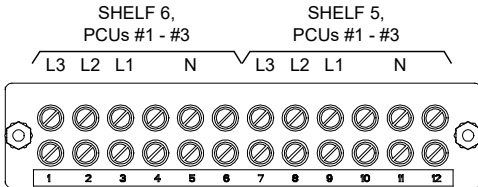
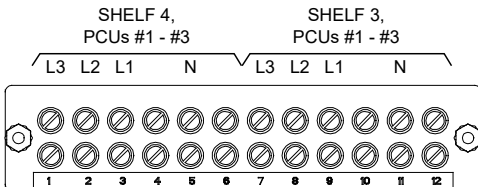
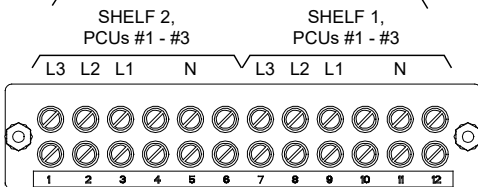
Rectifier Module (PCU) Mounting Slots

NOTE:  
WIRING TO A FIELD INSTALLED SHELF IS DONE AT THE REAR OF THE SHELF.

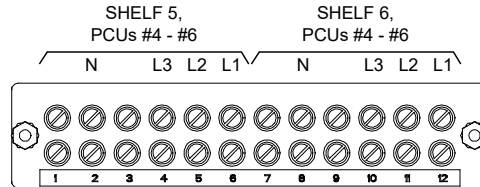
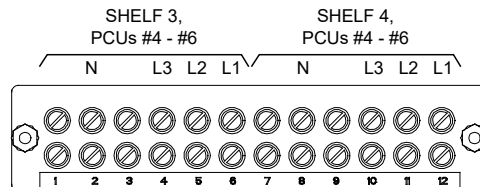
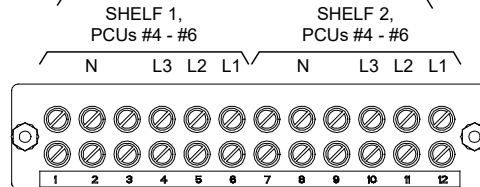
(4-Row Cabinet Shown, Others Similar)



RECTIFIER (PCU) AC INPUT FEEDS  
1 FEED PER 3 RECTIFIERS (PCU)  
277 VAC / 480 VAC, 50 Hz / 60 Hz, THREE PHASE



RECTIFIER (PCU) AC INPUT FEEDS  
1 FEED PER 3 RECTIFIERS (PCU)  
277 VAC / 480 VAC, 50 Hz / 60 Hz, THREE PHASE



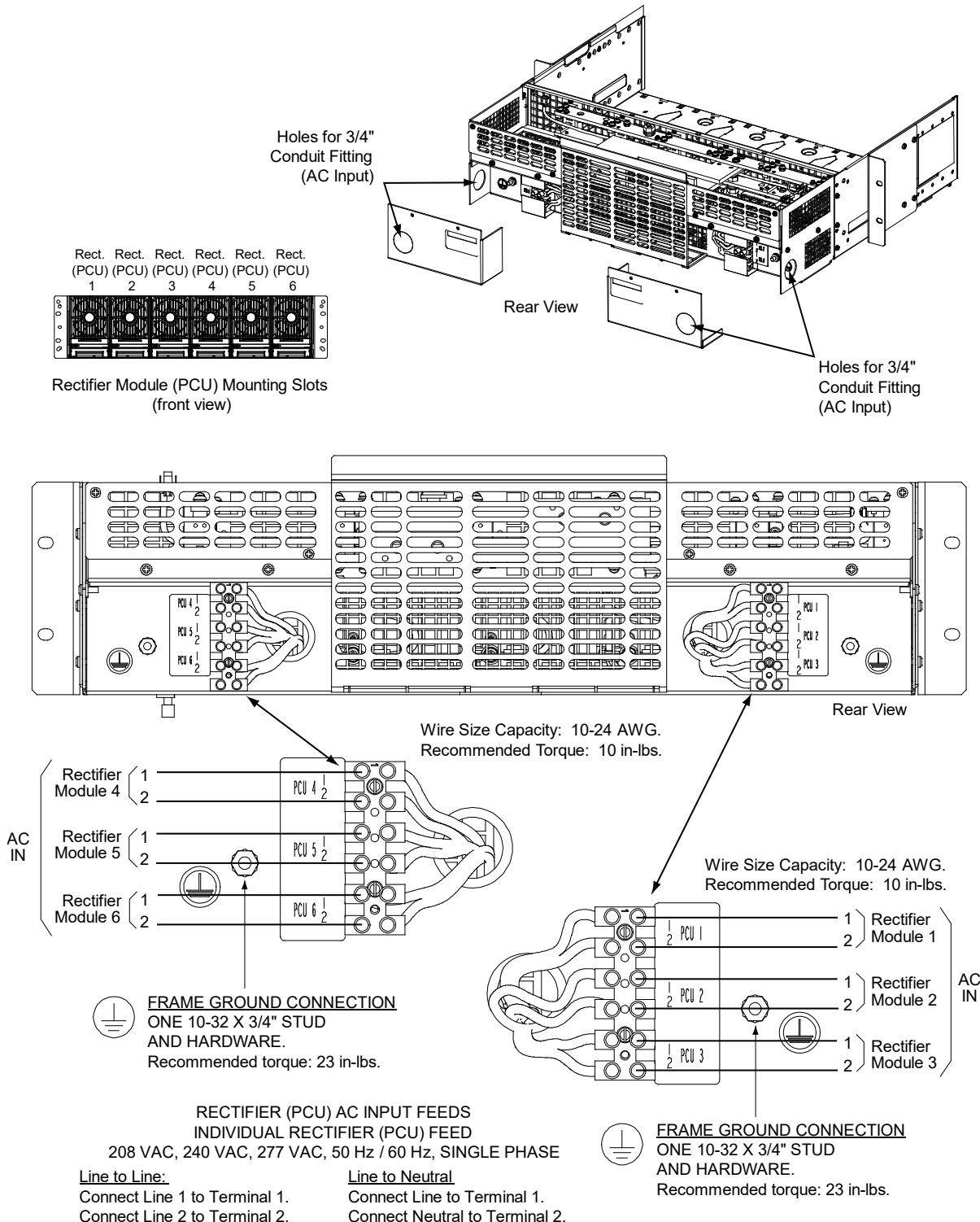
Note: Customer wiring to top terminals of terminal blocks.  
For fewer power shelves than shown, only the connections for the installed shelves are present.

Note: The three-phase input is internally distributed within the system to provide a single-phase line to neutral connection to each rectifier position, evenly distributed across the three phases.

**Direct AC Input Connections to 588705000 List 31 and 588705500 List 03 Module Mounting Assemblies**

Refer to **Figure 17**.

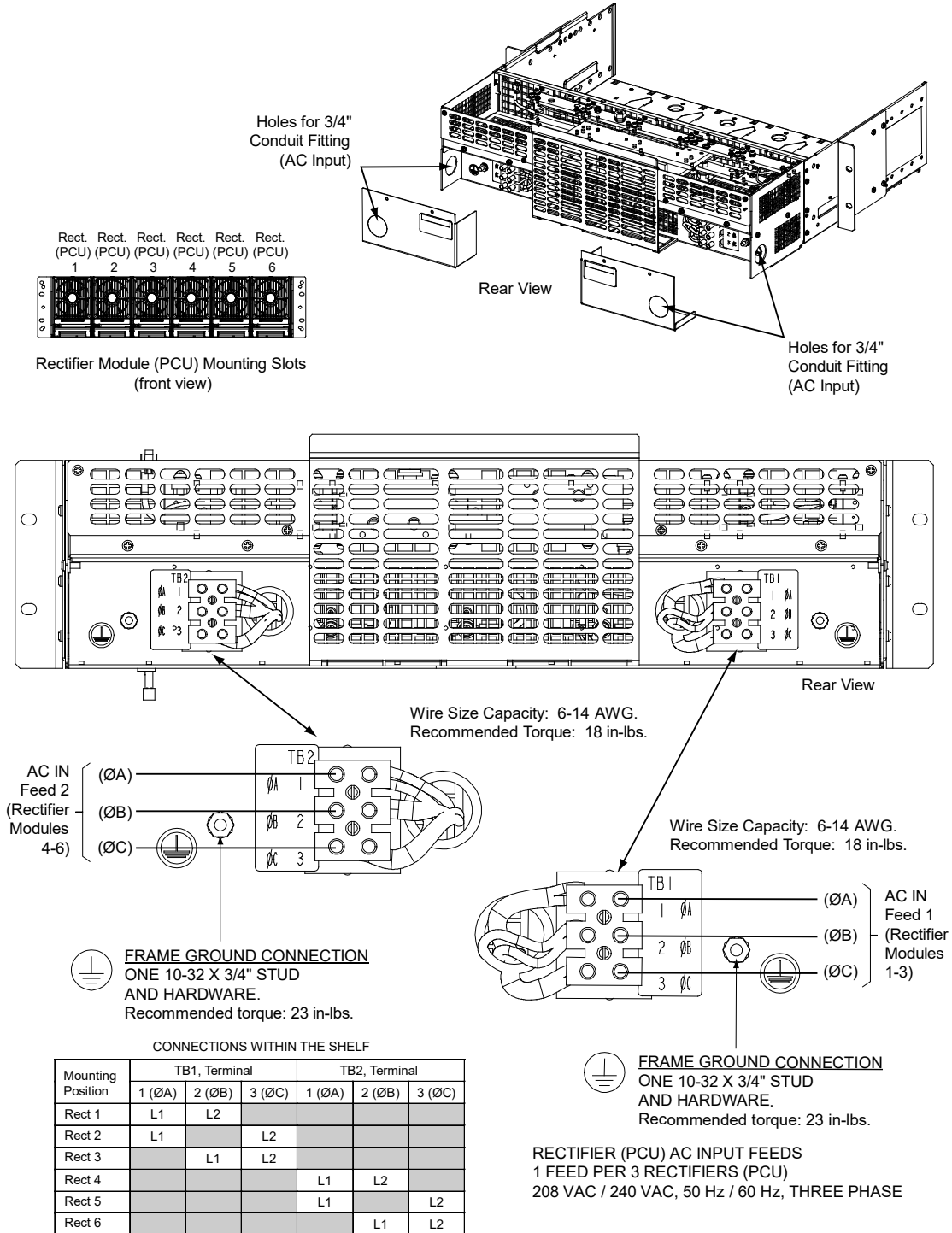
**Figure 5.9 Nominal 208 VAC, 240 VAC, 277 VAC Input Connections (Single-Phase) to a 588705000 List 31 and 588705500 List 03 Module Mounting Assembly**



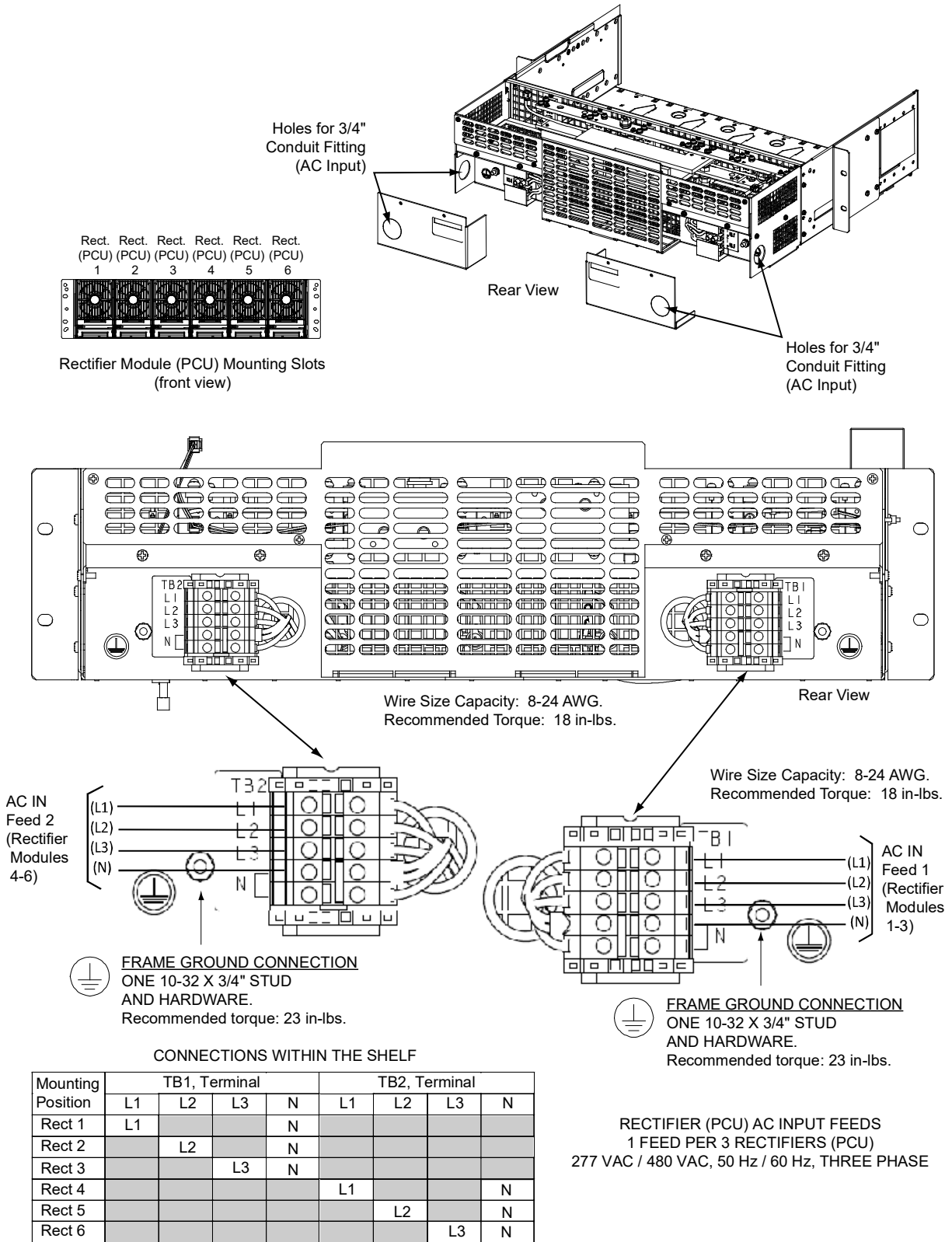
## Direct AC Input Connections to 588705000 List 32, List 33 and 588705500 List 04, List 05 Module Mounting Assemblies

Refer to **Figure 18** and **Figure 19**.

**Figure 5.10** Nominal 208 VAC / 240 VAC Input Connections (Three-Phase) to a 588705000 List 32 and 588705500 List 04 Module Mounting Assembly



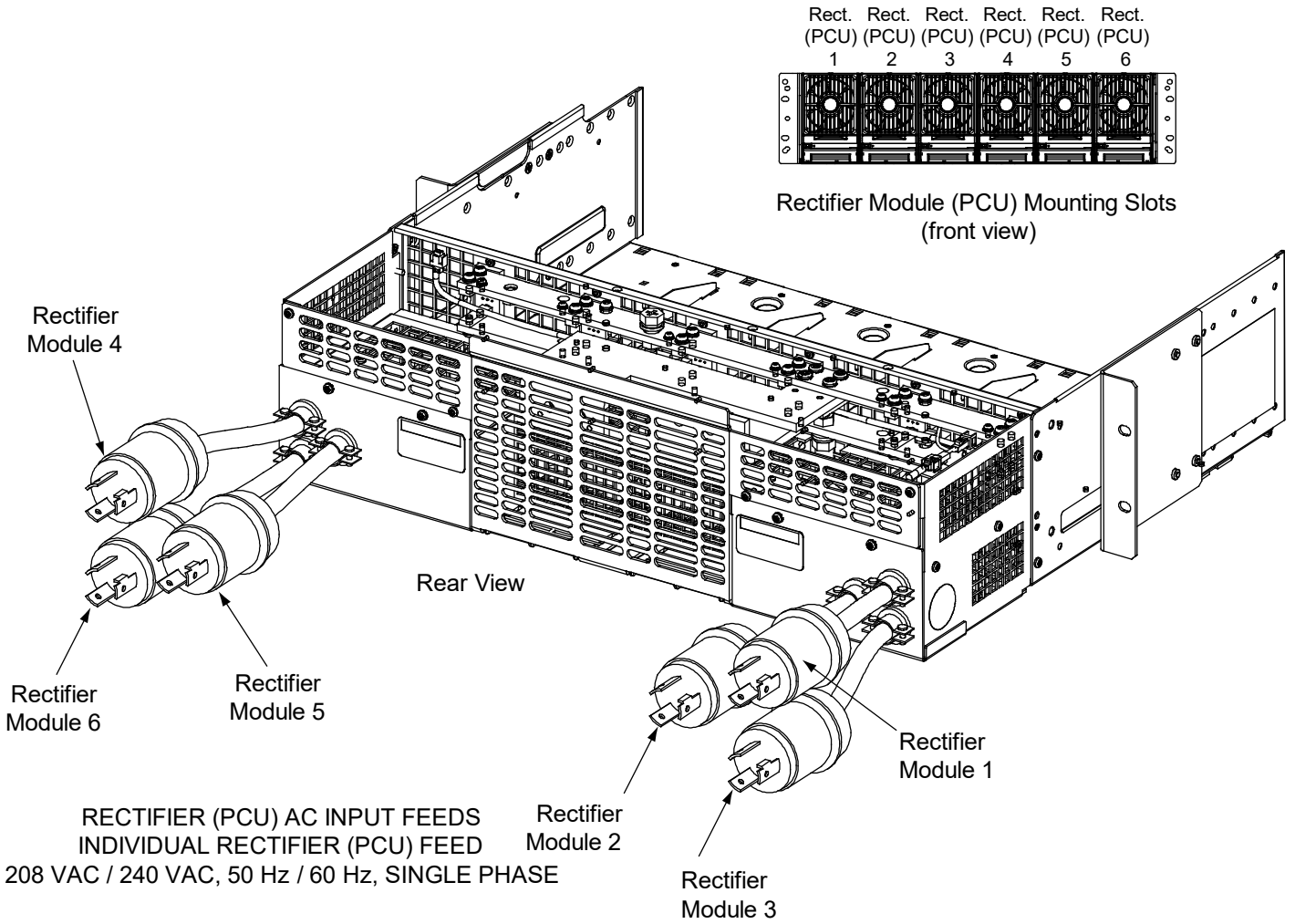
**Figure 5.11 Nominal 277 VAC / 480 VAC Input Connections (Three-Phase) to a 588705000 List 33 and 588705500 List 05 Module Mounting Assembly**



**Direct AC Input Connections to 588705000 List 22 and 588705500 List 02 Module Mounting Assemblies**

Refer to **Figure 20**.

**Figure 5.12** Nominal 208 VAC / 240 VAC Input and Equipment Grounding Connections to Module Mounting Assembly  
588705000 List 22 and 588705500 List 02  
(Single Phase, Line Cords)

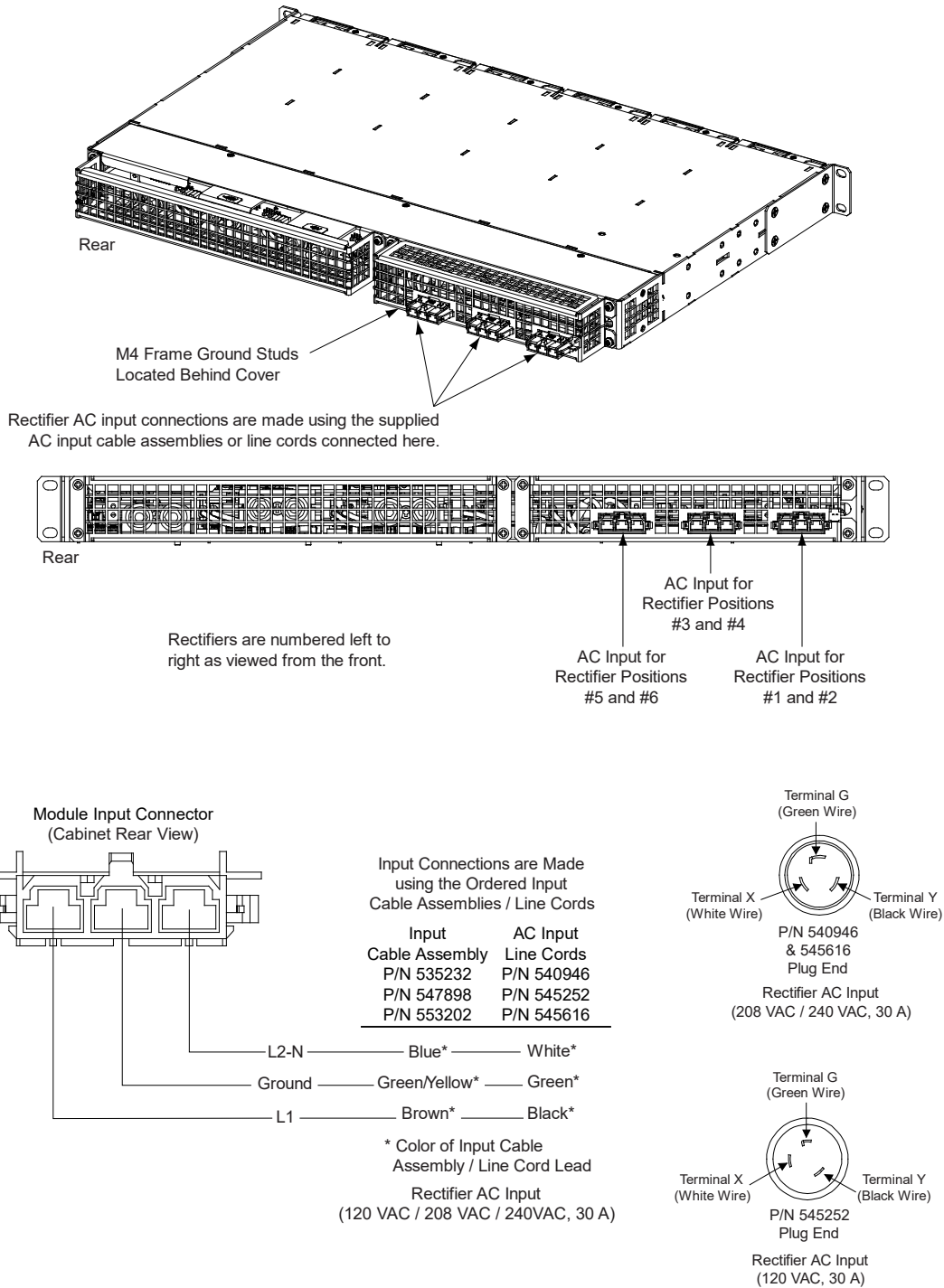




### Direct AC Input Connections to 588705300 List 03 Module Mounting Assemblies

Refer to **Figure 21**.

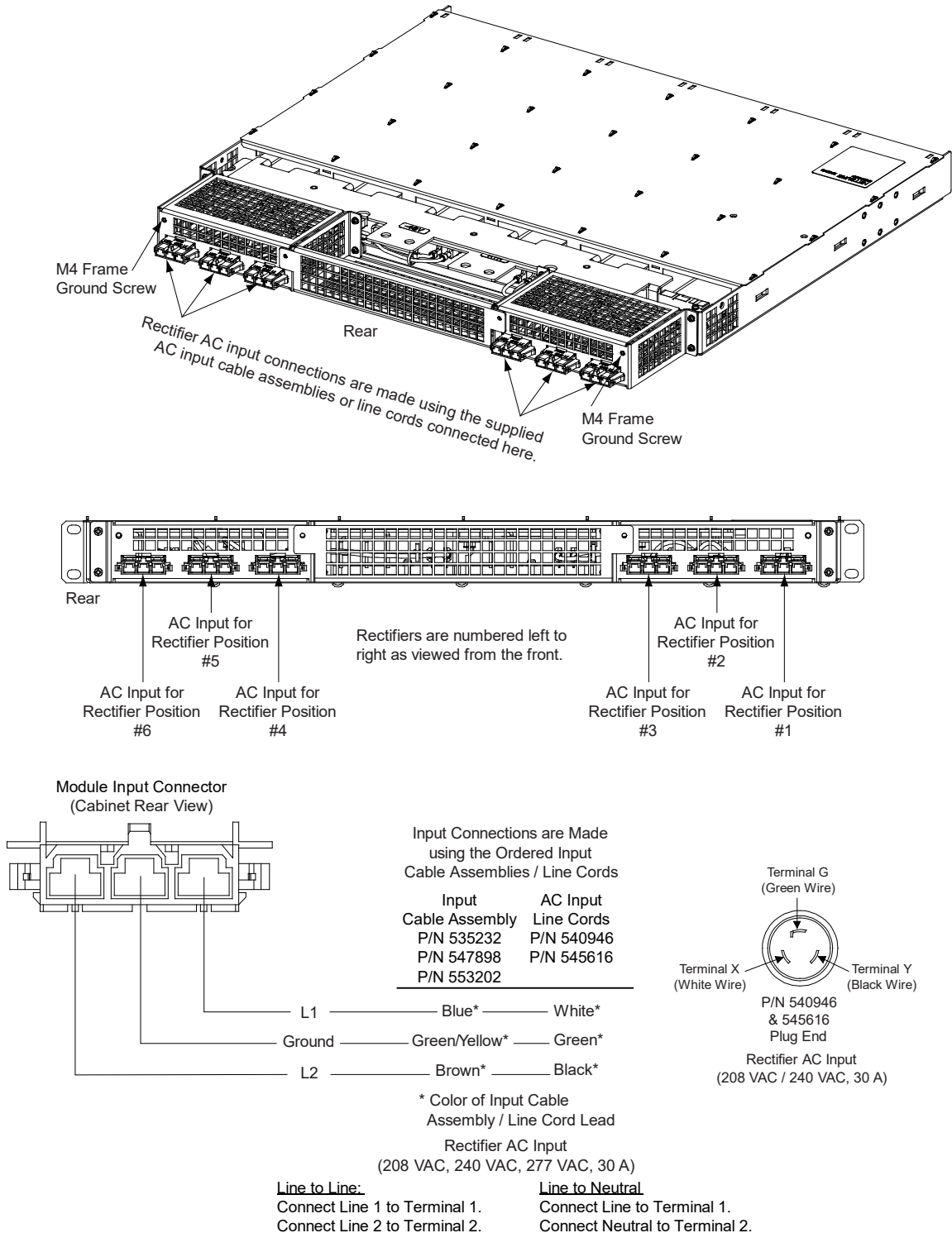
**Figure 5.13** Nominal 120 VAC / 208 VAC / 240 VAC Input and Equipment Grounding Connections to Module Mounting Assembly 588705300 List 03 (Single Phase, Cable Assemblies or Line Cords)



## Direct AC Input Connections to 588705400 List 02 Module Mounting Assemblies

Refer to **Figure 22**.

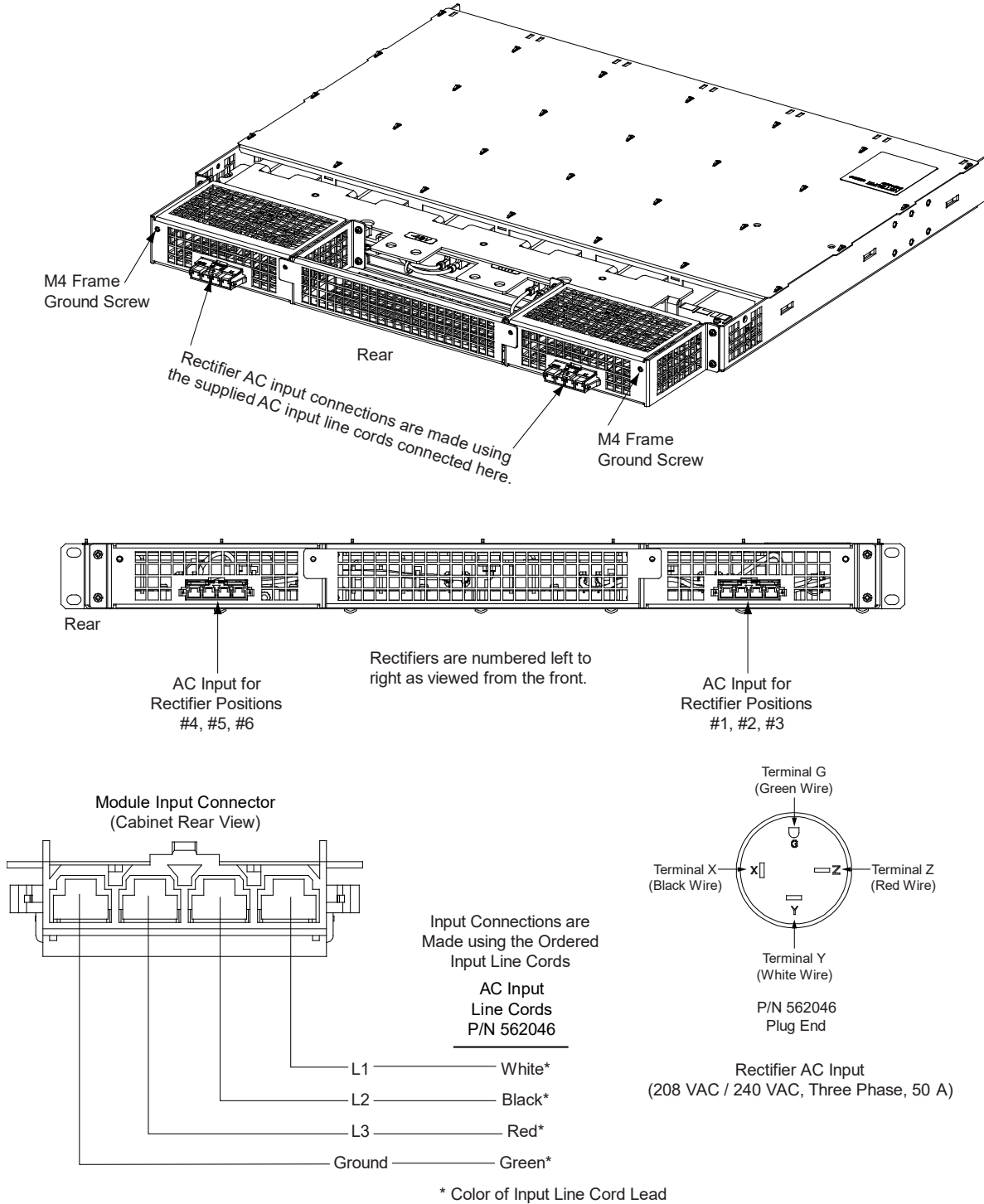
**Figure 5.14** Nominal 208 VAC, 240 VAC, 277 VAC Input and Equipment Grounding Connections to Module Mounting Assembly 588705400 List 02 (Single Phase, Cable Assemblies or Line Cords)  
(The 277 VAC input rating does not apply to line cords supplied with plugs.)



### Direct AC Input Connections to 588705400 List 03 Module Mounting Assemblies

Refer to **Figure 23**.

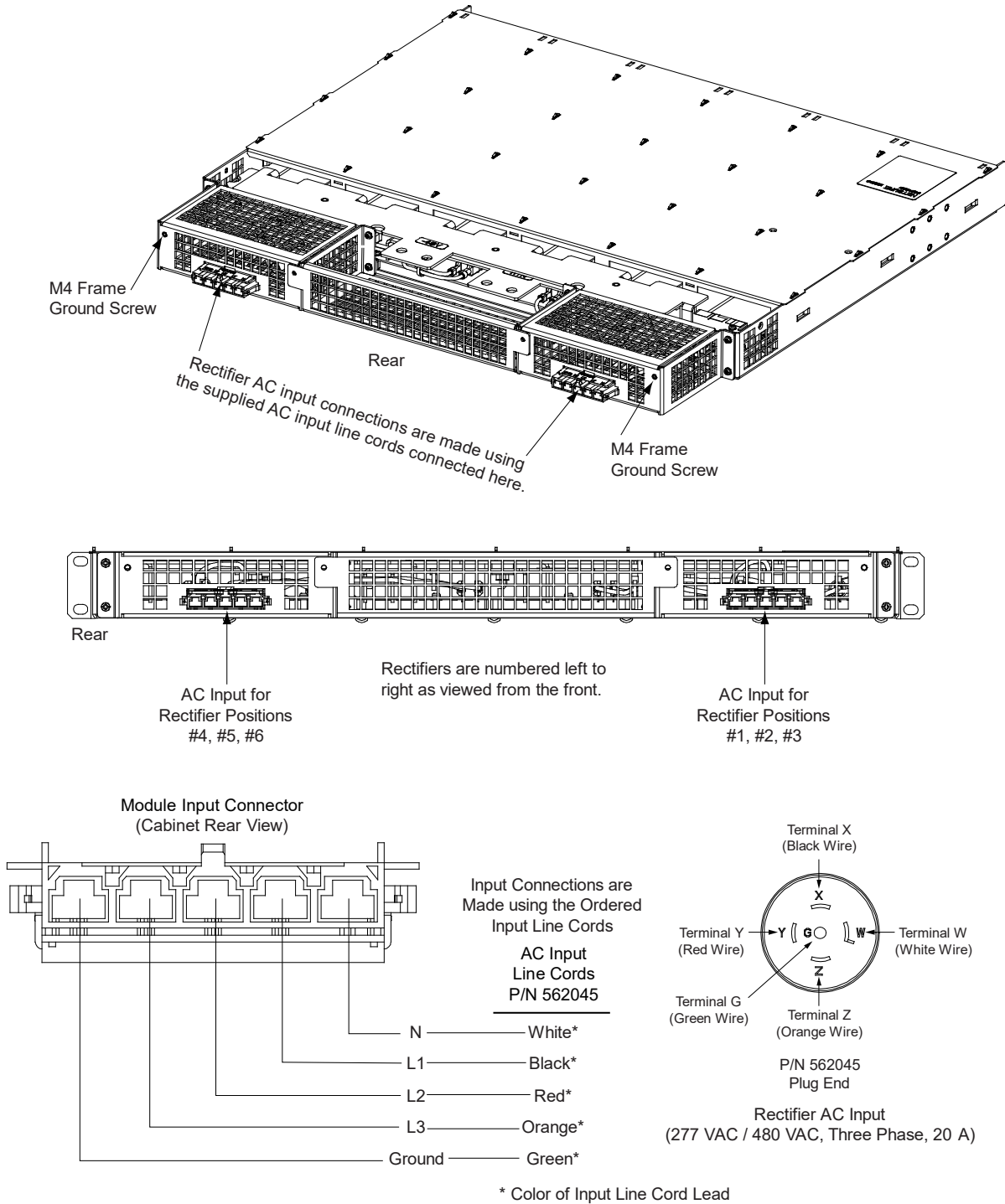
**Figure 5.15** Nominal 208 VAC / 240 VAC Input Connections (Three-Phase) to a 588705400 List 03 Module Mounting Assembly



### Direct AC Input Connections to 588705400 List 04 Module Mounting Assemblies

Refer to **Figure 24**.

**Figure 5.16** Nominal 277 VAC / 480 VAC Input Connections (Three-Phase) to a 588705400 List 04 Module Mounting Assembly



## 5.3 Make Nominal 400 Volts DC Input and Equipment Grounding Connections (if equipped)

Refer to *Nominal 400 Volts DC Input and Equipment Grounding Connections (if equipped)* in the MAKING ELECTRICAL CONNECTIONS section of the Installation Instructions (IM582127000) for a complete procedure.

NOTE THAT THIS SYSTEM MAY BE EQUIPPED WITH AC OR DC INPUTS. THESE PROCEDURES APPLY TO SYSTEMS WITH DC INPUTS. SPECIFICALLY, THESE PROCEDURES APPLY TO THE FOLLOWING EQUIPMENT:

- 582127000 List 45, 46, 47
- 588705000 List 41, 42

### **DC Input Termination Assemblies**

The available DC input options for this system are:

- The system can be equipped with a DC input termination assembly which provides a separate DC input connection for each converter position (582127000 List 45).
- The system can be equipped with a DC input termination assembly which provides a separate DC input connection for every two (2) converter positions (582127000 List 46).
- The system can be equipped with a DC input termination assembly which provides a separate DC input connection for every three (3) converter positions (582127000 List 47).

### **Direct DC Input Connections to the Module Mounting Assemblies**

- The system can be equipped with module mounting assemblies that contain DC input terminal blocks which provide a separate DC input connection for each converter position (588705000 List 41).
- The system can be equipped with module mounting assemblies that contain DC input terminal blocks which provide a separate DC input connection for every two (2) converter positions (588705000 List 42).

### **Connections to DC Input Termination Assemblies (582127000 List 45, 46, and 47)**

Refer to **Figure 25**, **Figure 26**, or **Figure 27**.



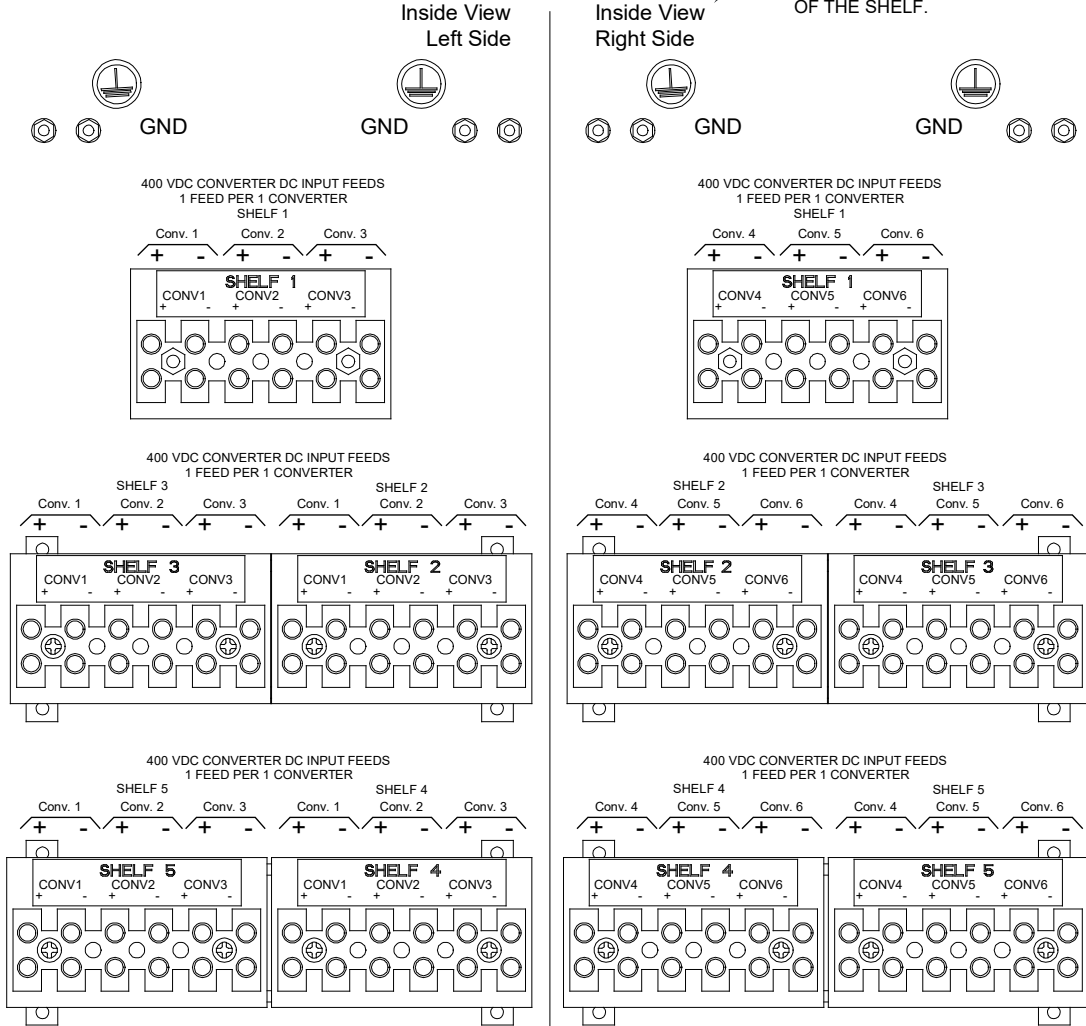
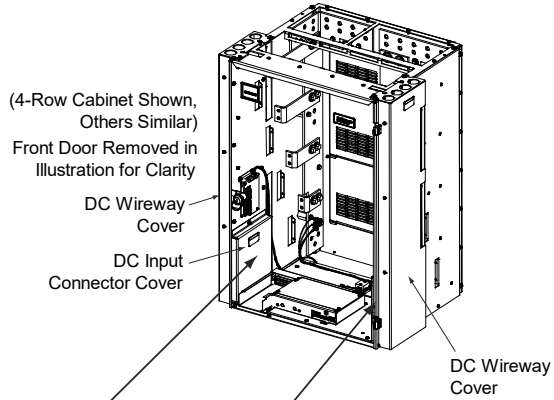
**NOTE!** Terminal blocks for a system with maximum possible converter shelves shown. Your system may have less terminal blocks than shown.

**Figure 5.17 400 Volts DC Input and Equipment Grounding Connections to DC Input Termination Assembly 582127000 List 45 (1 Feed per 1 Converter)**

DC INPUT CONNECTIONS,  
1 FEED PER 1 CONVERTER  
(582127000 LIST 45)

Conv. 1	Conv. 2	Conv. 3	Conv. 4	Conv. 5	Conv. 6	Shelf #1 Shelf #2 Shelf #3 Shelf #4 Shelf #5
Conv. 1	Conv. 2	Conv. 3	Conv. 4	Conv. 5	Conv. 6	
Conv. 1	Conv. 2	Conv. 3	Conv. 4	Conv. 5	Conv. 6	
Conv. 1	Conv. 2	Conv. 3	Conv. 4	Conv. 5	Conv. 6	
Conv. 1	Conv. 2	Conv. 3	Conv. 4	Conv. 5	Conv. 6	

Converter Module Mounting Slots



Note: For fewer power shelves than shown, only the connections for the installed shelves are present.

**Figure 5.18 400 Volts DC Input and Equipment Grounding Connections to DC Input Termination Assembly 582127000 List 46 (1 Feed per 2 Converters)**

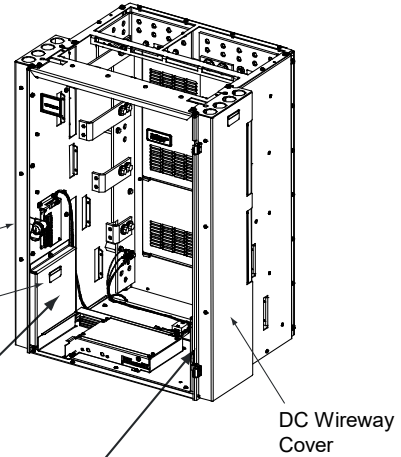
**DC INPUT CONNECTIONS,  
1 FEED PER 2 CONVERTERS  
(582127000 LIST 46)**

Conv. 1	Conv. 2	Conv. 3	Conv. 4	Conv. 5	Conv. 6	Shelf #1 Shelf #2 Shelf #3 Shelf #4
Conv. 1	Conv. 2	Conv. 3	Conv. 4	Conv. 5	Conv. 6	
Conv. 1	Conv. 2	Conv. 3	Conv. 4	Conv. 5	Conv. 6	
Conv. 1	Conv. 2	Conv. 3	Conv. 4	Conv. 5	Conv. 6	

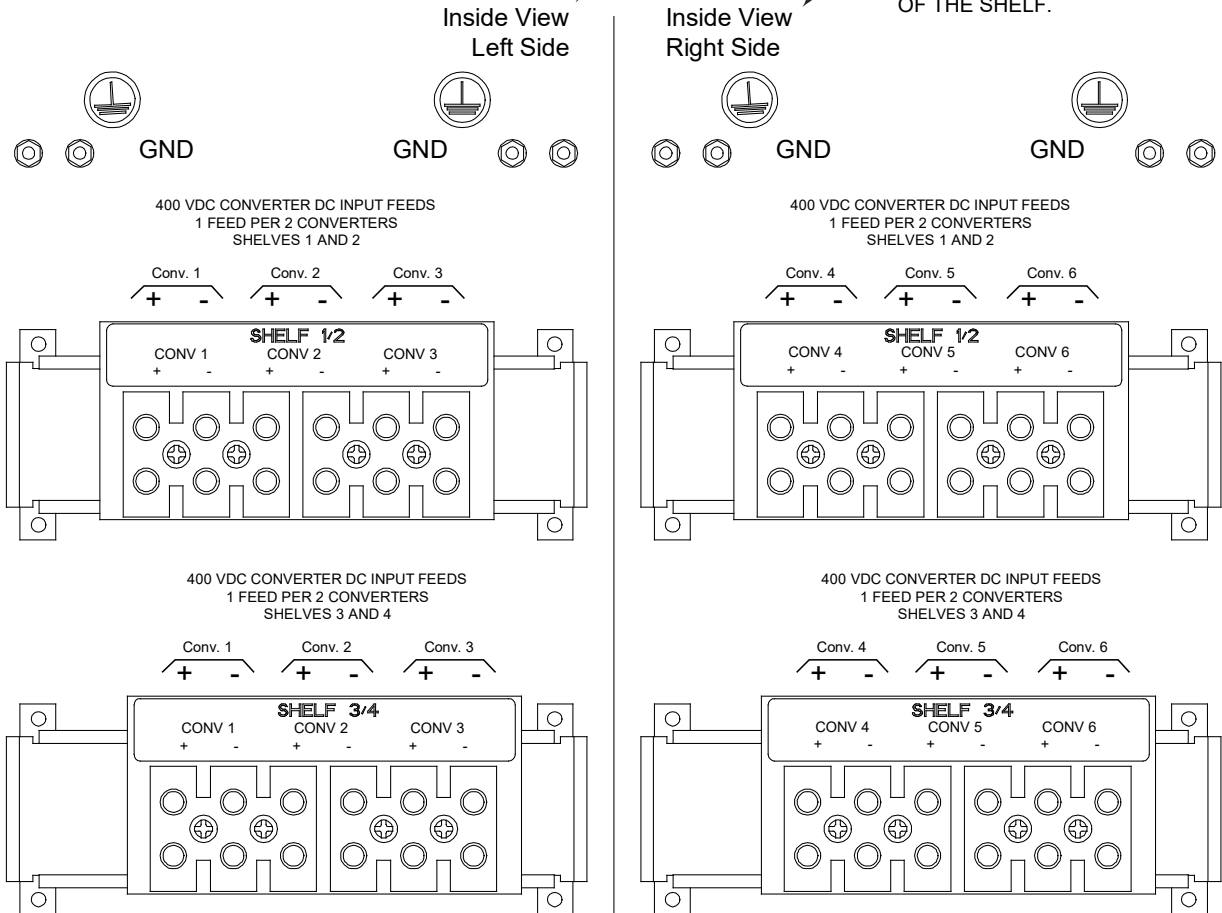
Converter Module Mounting Slots

(4-Row Cabinet Shown, Others Similar)  
Front Door Removed in Illustration for Clarity

DC Wireway Cover  
DC Input Connector Cover



NOTE:  
WIRING TO A FIELD INSTALLED SHELF IS DONE AT THE REAR OF THE SHELF.



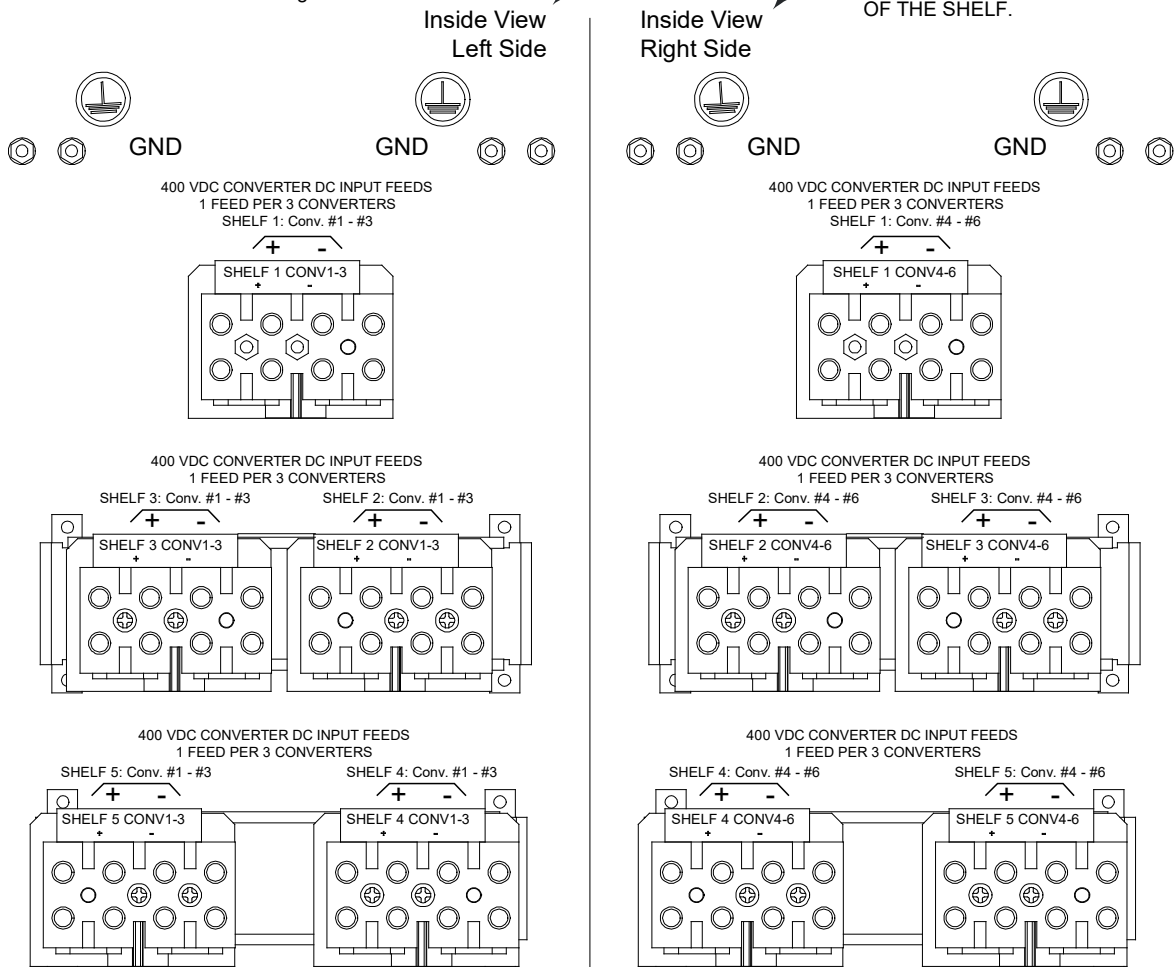
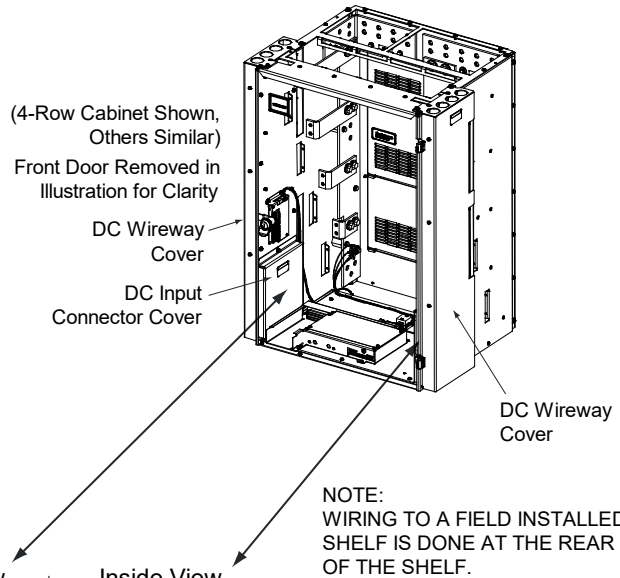
Note: For fewer power shelves than shown, only the connections for the installed shelves are present.

**Figure 5.19 400 Volts DC Input and Equipment Grounding Connections to DC Input Termination Assembly 582127000 List 47 (1 Feed per 3 Converters)**

**DC INPUT CONNECTIONS,  
1 FEED PER 3 CONVERTERS  
(582127000 LIST 47)**

Conv. 1	Conv. 2	Conv. 3	Conv. 4	Conv. 5	Conv. 6	Shelf #1
Conv. 1	Conv. 2	Conv. 3	Conv. 4	Conv. 5	Conv. 6	Shelf #2
Conv. 1	Conv. 2	Conv. 3	Conv. 4	Conv. 5	Conv. 6	Shelf #3
Conv. 1	Conv. 2	Conv. 3	Conv. 4	Conv. 5	Conv. 6	Shelf #4
Conv. 1	Conv. 2	Conv. 3	Conv. 4	Conv. 5	Conv. 6	Shelf #5

Converter Module Mounting Slots



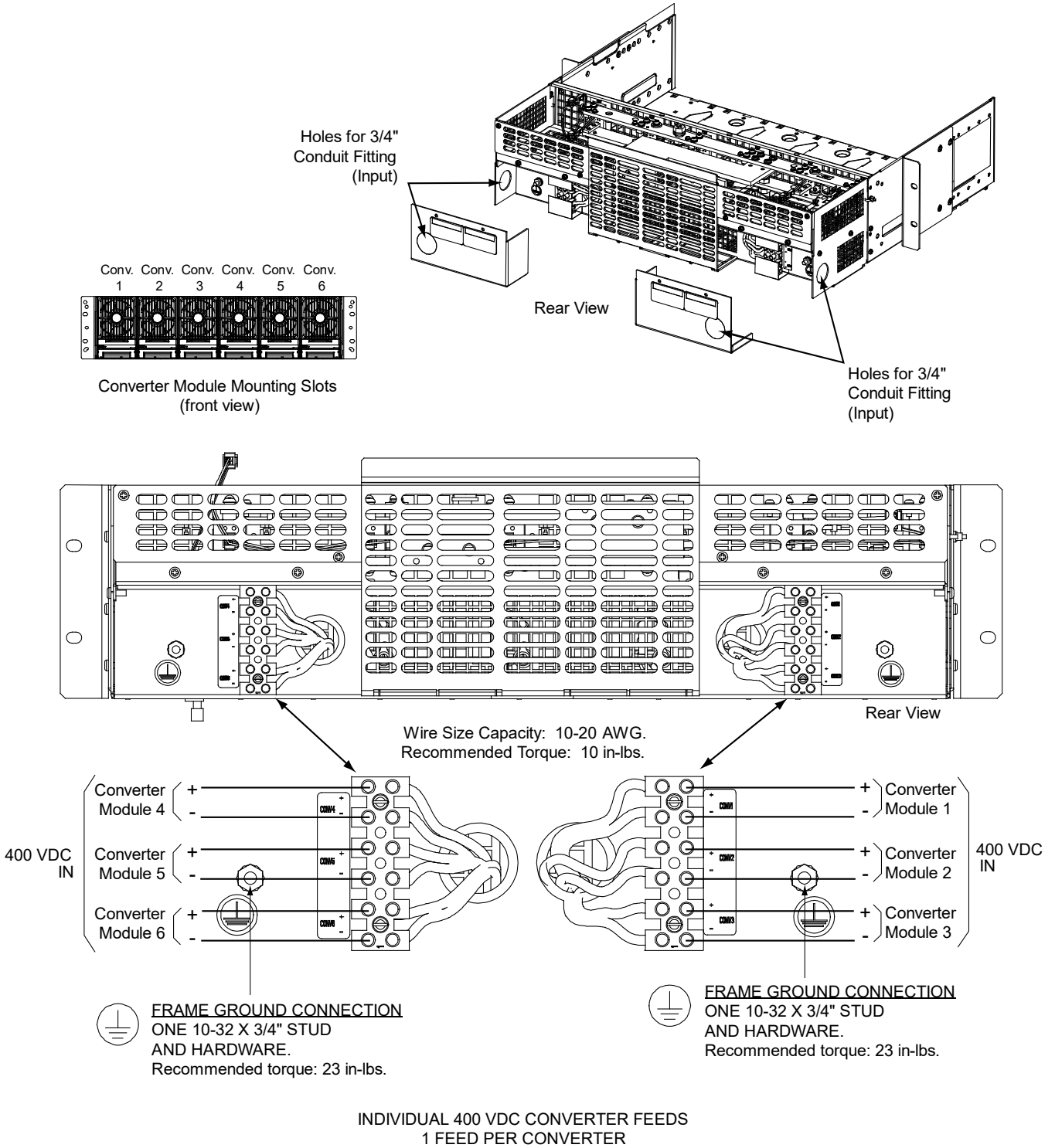
Note: For fewer power shelves than shown, only the connections for the installed shelves are present.



### Direct DC Input Connections to 588705000 List 41 Module Mounting Assemblies

Refer to **Figure 28**.

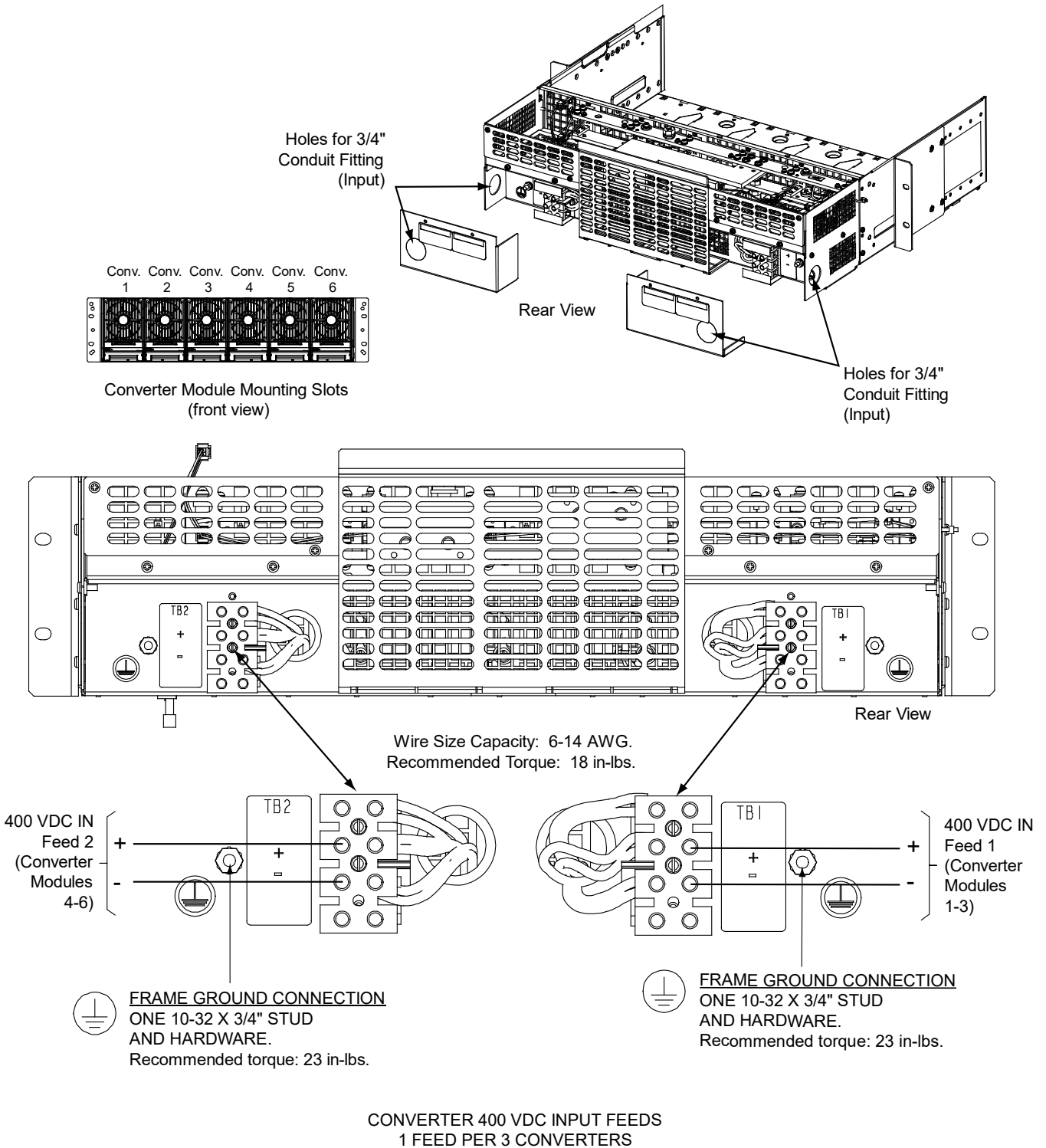
**Figure 5.20** 400 Volts DC Input and Equipment Grounding Connections to Module Mounting Assembly 588705000 List 41 (1 Feed per 1 Converter)



### Direct DC Input Connections to 588705000 List 42 Module Mounting Assemblies

Refer to **Figure 29**.

**Figure 5.21** 400 Volts DC Input and Equipment Grounding Connections to Module Mounting Assembly 588705000 List 42 (1 Feed per 3 Converters)



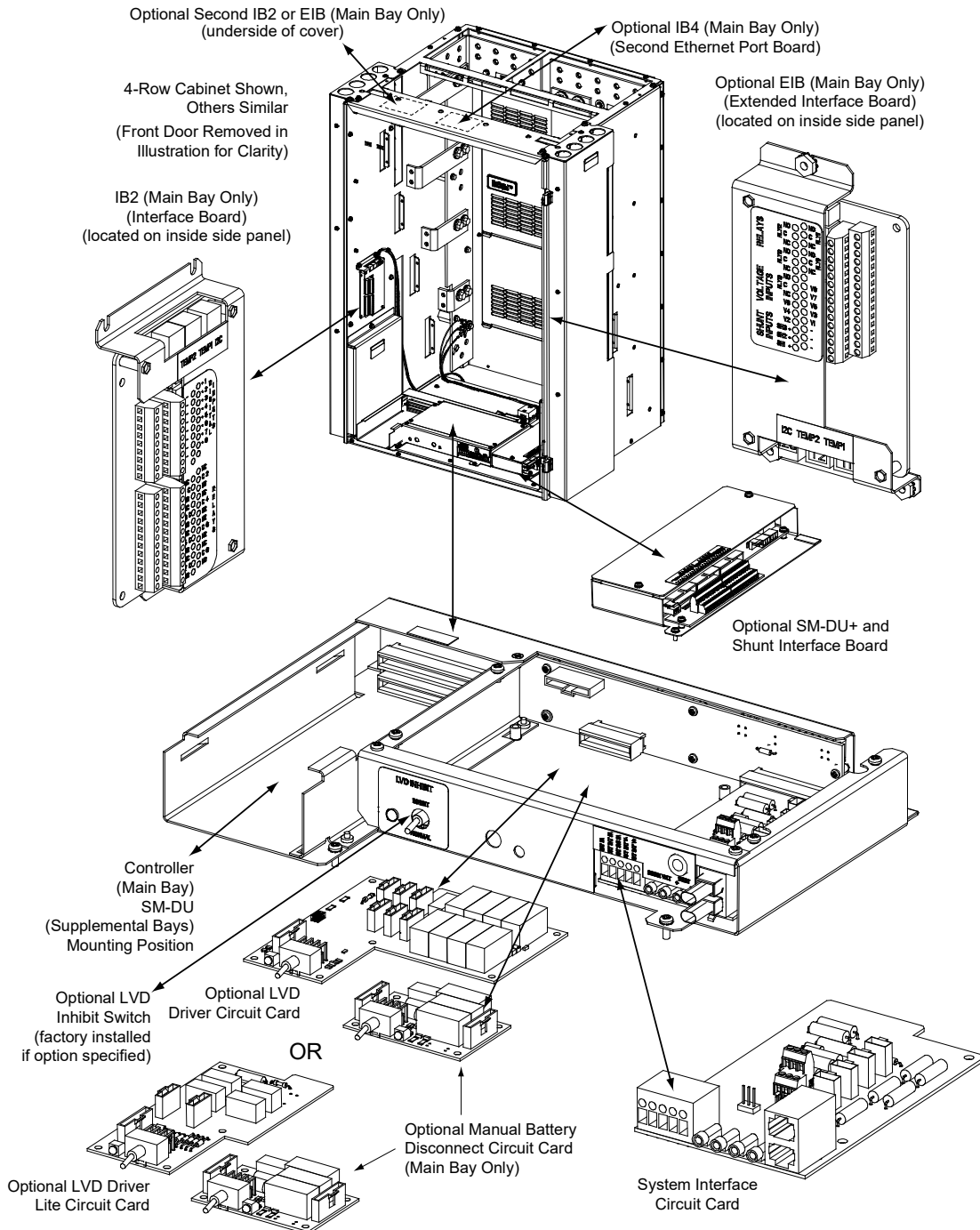
## 5.4 Make External Alarm, Reference, Monitoring, and Control Connections

Refer to *External Alarm, Reference, Monitoring, and Control Connections* in the MAKING ELECTRICAL CONNECTIONS section of the Installation Instructions (IM582127000) for complete procedures.

### 5.4.1 Circuit Card Locations

Refer to **Figure 30**.

**Figure 5.22** Circuit Card Locations



## 5.4.2 System Interface Circuit Card

The System Interface Circuit Card provides connections for the following. Refer to **Figure 31**.

- **Battery Tray FA Signal:** This input is used to provide a battery tray fuse alarm (FA) on the controller due to a tripped battery disconnect breaker on a battery tray in the power system rack. Application of system voltage to pin TB1-1 activates this alarm. The lead should be protected at the source with an in-line fusible resistor. The source should be originated from the system side of the disconnect device, not the battery side. If used with List 93 battery tray option this connection is applied in the factory.
- **External Battery FA Signal (circuit card installed in Main Bay only):** This input is used to provide an external battery fuse alarm (FA) on the controller due to a tripped battery disconnect device (fuse, breaker or contactor) external to the power system rack. Application of system voltage to pin TB1-2 activates this alarm. The lead should be protected at the source with an in-line fusible resistor. The source should be originated from the system side of the disconnect device, not the battery side.
- **External System FA Signal (circuit card installed in Main Bay only):** This input is used to provide an external system fuse alarm (FA) on the controller due to a tripped distribution device (fuse or breaker) on the system output external to the power system distribution cabinet. Application of system voltage to pin TB1-3 activates this alarm. The lead should be protected at the source with an in-line fusible resistor. This input is not to be used for any voltage bus (such as converter output) other than the system bus.
- **External Battery Monitoring (circuit card installed in Main Bay only):** If the jumper J10 is set to External (see **Figure 8**), connect TB1-4 and TB1-5 to the desired battery voltage sensing point. Observe proper polarity per the **Figure 8**. The hot sense lead should be protected at the source with an in-line fuse or fusible resistor.

- RS-485 (used for communication with SM modules)

(Also used when an NCU configuration is furnished that enables NCU capability to receive status information sent from Fiamm SoNick [Sodium Nickel] batteries. Connect leads from the Fiamm SoNick batteries to the RS-485 terminals. See **Figure 31**. Refer to the battery manufacturer documentation and the NCU controller manual UM1M830BNA for details.)

- RS-232 (used for communication with a DPU)
- **Bay Voltage Monitoring Test Points:** Provide system bus voltage measurement for an external meter. The leads are protected against fault with 10kohm series resistors in each lead.
- **Bay Load Shunt Monitoring Test Points:** Provide for measurement of the system load shunt in the bay. See below for shunt ratings. The leads are protected against fault with 10kohm series resistors in each lead.

List 21, 1-Row Distribution Cabinet: 800A / 25mV (32A per mV)

List 22, 2-Row Distribution Cabinet: 2000A / 25mV (80A per mV)

List 23, 3-Row Distribution Cabinet: 2500A / 25mV (100A per mV)

List 24, 4-Row Distribution Cabinet: 2500A / 25mV (100A per mV)

**Figure 5.23 System Interface Circuit Card Connections**

\* When an NCU configuration is furnished that enables NCU capability to receive status information sent from Fiamm SoNick [Sodium Nickel] batteries. Connect leads from the Fiamm SoNick batteries to the RS-485 terminals. Refer to the battery manufacturer documentation and the NCU controller manual UM1M830BNA for details.

**TB2**

**RS485 Connection\***

TB2 1A: RS485+  
TB2 2A: RS485-

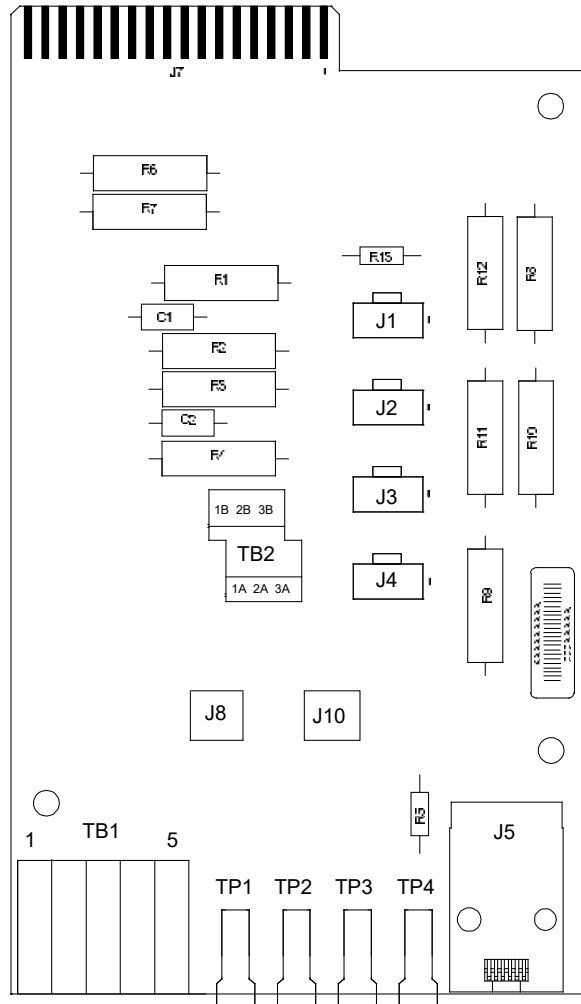
**RS232 Connection**

TB2 1B: CGND  
TB2 2B: TXD232  
TB2 3B:RXD232

TB2 3A: Internally used by system.

**TB2**

Wire Size Capacity: 16-26 AWG.  
Recommended Torque: 2.0 in-lbs.

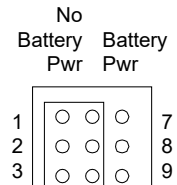


**J1, J2, J3, J4**

Distribution Panels FA Inputs

**J8 (Main Bay Only)**

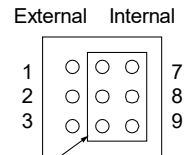
Selects to power Controller from "Battery Power" or not.



Shorting Jumper

**J10 (Main Bay Only)**

Battery Monitoring External / Internal (see TB1-4 and TB1-5 for external monitoring points)



Shorting Jumper

**J5**

CAN2 (top)  
CAN1 (bottom)

- TB1-1: Battery Tray FA
- TB1-2: External Battery FA
- TB1-3: External System FA
- TB1-4: External Battery Monitoring (-)
- TB1-5: External Battery Monitoring (+)
- TP1 (+) and TP2 (-): Bay Voltage Monitoring
- TP3 (+) and TP4 (-): Bay Load Shunt Monitoring

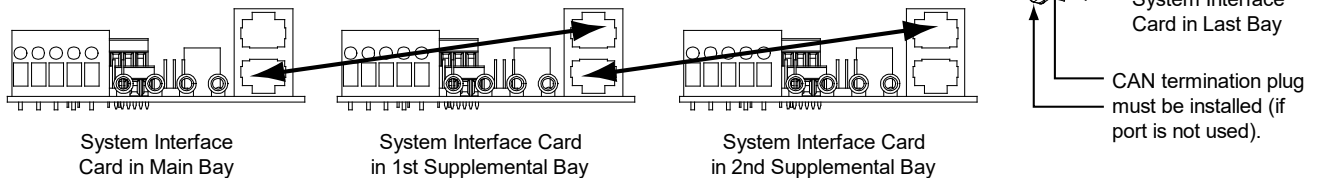
**TB1**

TB1-2, TB1-3, TB1-4, TB1-5 Main Bay Only.

Wire Size Capacity: 22-12 AWG.

Recommended Torque: 3.0 in-lbs.

FA Signals: System voltage applied to the terminal turns in an alarm.



### 5.4.3 IB2 (Controller Interface Board) Connections (if required) (Main Bay Only)



**NOTE!** The system may have one (1) or two (2) IB2 boards installed. The first IB2 is standard while the second IB2 is optional.

Each IB2 (Controller Interface Board) provides connection points for digital inputs, programmable relay outputs, and temperature probes. The IB2 interface boards are mounted inside the distribution cabinet. Refer to **Figure 30**.

#### **Digital Inputs and Programmable Relay Outputs**

Digital input and relay output leads are connected to screw-type terminal blocks located on the IB2. Recommended torque for these connections is 2.2 in-lbs. Refer to **Figure 32** for terminal locations. Refer to **Table 1** and **Table 2** for pin-out information.

#### **Digital Inputs**

Connect up to eight (8) digital inputs to each IB2. Note that you must supply both paths for the digital input (either a positive or negative signal and the opposite polarity return path). Observe proper polarity. Refer to **Figure 32** for terminal locations and **Table 1** for pin-out information.



**NOTE!** First IB2 Board Only: -48V is factory wired to the Digital Input #8 (-) terminal for your convenience and function predefined for ESTOP. Customer-furnished system ground applied to terminal Digital Input #8 (+) activates the ESTOP function. The ESTOP function shuts down and locks out the rectifiers or 400V DC input converters, opens the LVD's, and shuts down the optional -48V to +24V DC converters. When the ESTOP signal is removed, LVD's close (if battery present) and -48V to +24V DC converters restart. To restart the rectifiers or 400V DC input converters; turn input power to the rectifiers/converters OFF, wait 30 seconds or more (until the LEDs on the module extinguish), then turn input power to the rectifiers/converters ON.

The digital inputs can be programmed to provide an alarm when the signal is applied (HIGH) or removed (LOW). Refer to the ACU+ Instructions (UM1M820BNA or UM1M820DNA400) or NCU Instructions (UM1M830BNA) for programming information.

Digital Input Ratings: Refer to the following.

- a) Maximum Voltage Rating: 60V DC.
- b) Active High: > 19V DC.
- c) Active Low: < 1V DC.

The digital inputs may be preprogrammed for specific functions. Refer to the configuration drawing (C-drawing) supplied with your system for your system's specific configuration.

#### **Programmable Relay Outputs**

Each IB2 provides eight (8) programmable alarm relays with dry Form-C contacts. Connect up to eight (8) relay outputs to the IB2. Refer to **Figure 32** for terminal locations and **Table 2** for pin-out information.



**NOTE!** The relay assigned to "Critical Summary" alarm (Relay 1 on first IB2 by default) will operate in the "Fail Safe Mode". "Fail Safe Mode" means Relay 1 is de-energized during an alarm condition, opening the contacts between the C and NO terminals, and closing the contacts between the C and NC terminals.

The remaining 7 relays energize during an alarm condition, closing the contacts between the C and NO terminals, and opening the contacts between the C and NC terminals.

Refer to the ACU+ Instructions (UM1M820BNA or UM1M820DNA400) or NCU Instructions (UM1M830BNA) for programming information.

Relay Ratings: Refer to the following.

- a) Steady State: 0.5 A @ 60V DC; 1.0 A @ 30V DC.
- b) Peak: 3 A @ 30V DC.

Each relays may be preprogrammed for specific functions. Refer to the configuration drawing (C-drawing) supplied with your system for your system's specific configuration.

## **Temperature Probes**



**NOTE!** Each temperature probe consists of two or three pieces that plug together to make a complete probe. See SAG582127000 for part numbers and descriptions.

Temperature probes can be connected to the IB2 (Controller Interface Board) and/or EIB (Controller Extended Interface Board) mounted inside the distribution cabinet. See **Figure 32** and **Figure 34**.

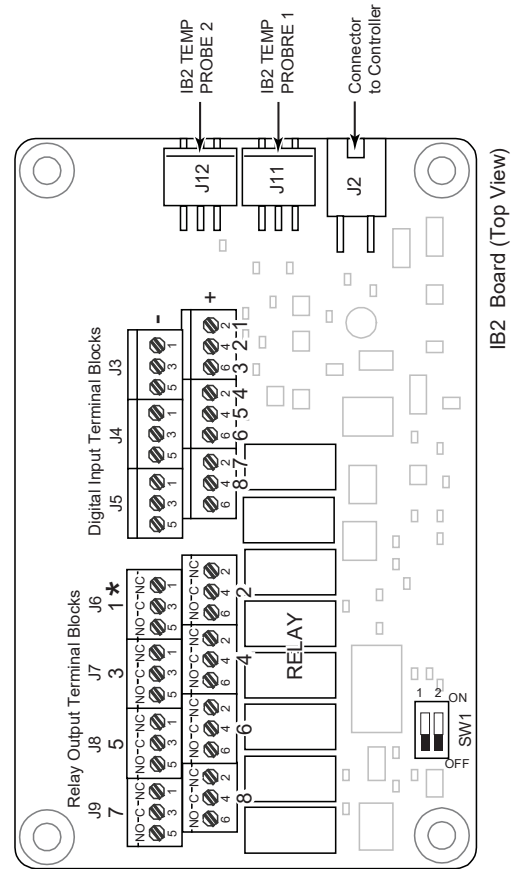
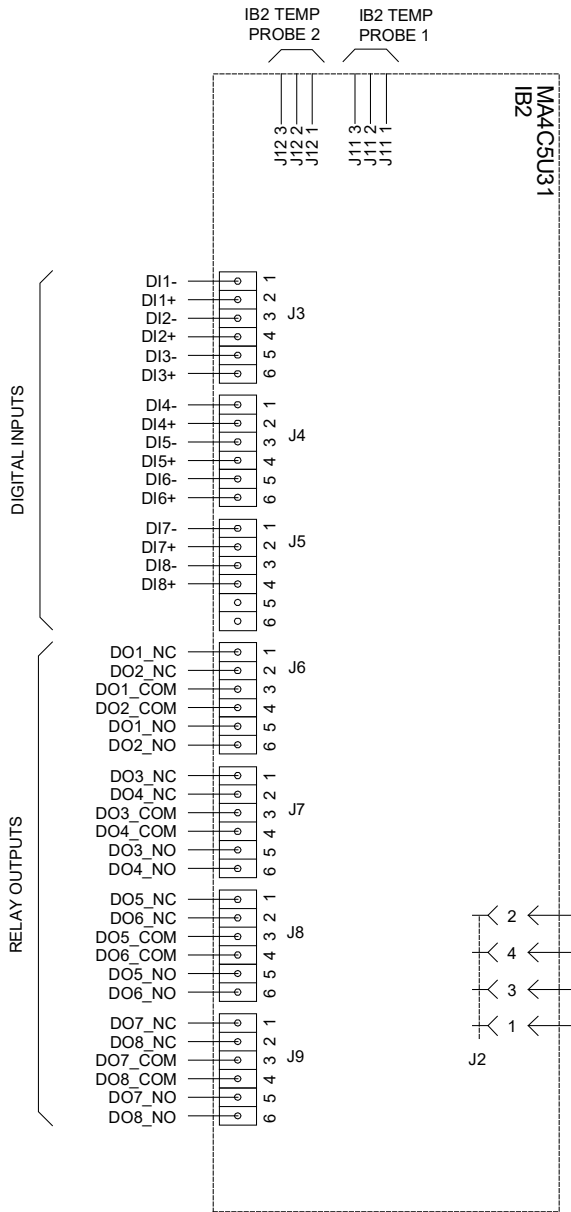
The IB2 and EIB board allows for the connection of two (2) temperature probes. Any combination of the temperature probes can be programmed to monitor ambient temperature and/or battery temperature. A temperature probe set to monitor battery temperature can also be used for the rectifier battery charge temperature compensation feature, or the battery charge temperature compensation feature can be programmed to use the average or highest value of all battery temperature probes. The battery charge temperature compensation feature allows the controller to automatically increase or decrease the output voltage of the system to maintain battery float current as battery temperature decreases or increases, respectively. Battery life can be extended when an optimum charge voltage to the battery with respect to temperature is maintained. A temperature probe set to monitor battery temperature can also be used for the BTRM (Battery Thermal Runaway Management) feature. The BTRM feature lowers output voltage when a high temperature condition exists to control against battery thermal runaway.

The temperature sensor end of the probe contains a tab with a 5/16" clearance hole for mounting.

A temperature probe programmed to monitor battery temperature should be mounted on the negative post of a battery cell to sense battery temperature. A temperature probe used for battery charge temperature compensation and/or BTRM (Battery Thermal Runaway Management) should also be mounted on the negative post of a battery cell. A temperature probe programmed to monitor ambient temperature should be mounted in a convenient location, away from direct sources of heat or cold.

**Figure 5.24 IB2-1 and IB2-2 (Interface Board) Connections**

**Schematic Diagram of IB2 Board**



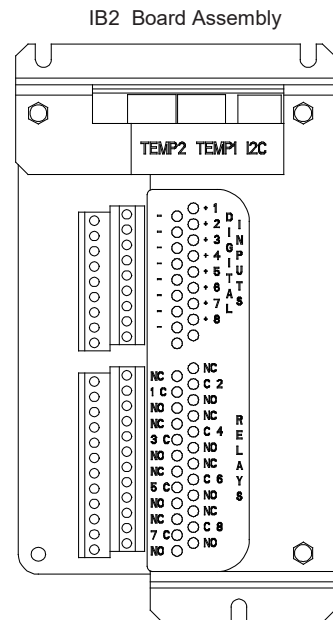
**J3-J9:**  
 Wire Size Capacity: 16-26 AWG.  
 Recommended Torque: 2.2 in-lbs.

\* The relay assigned to "Critical Summary" alarm (Relay 1 on first IB2 by default) will operate in the "Fail Safe Mode". "Fail Safe Mode" means Relay 1 is de-energized during an alarm condition, opening the contacts between the C and NO terminals, and closing the contacts between the C and NC terminals.

The remaining seven (7) relays energize during an alarm condition, closing the contacts between the C and NO terminals, and opening the contacts between the C and NC terminals.

Refer to the configuration drawing (C-drawing) supplied with your system for your system's specific relay labeling.

Not all I/O points are available for customer connection (some are used for factory system connections).





**Table 5.1 Programmable Digital Inputs – IB2 Board**

Programmable Digital Input	IB2 Pin No.		Factory Wiring	Default Digital Input Function	Customer Defined Digital Input Function
1	J3-2	+	The digital inputs may be preprogrammed for specific functions and have factory wiring connected. Refer to the configuration drawing (C-drawing) supplied with your system for your system's specific configuration.	The digital inputs may be preprogrammed for specific functions. Refer to the configuration drawing (C-drawing) supplied with your system for your system's specific configuration.	
	J3-1	-			
2	J3-4	+			
	J3-3	-			
3	J3-6	+			
	J3-5	-			
4	J4-2	+			
	J4-1	-			
5	J4-4	+			
	J4-3	-			
6	J4-6	+			
	J4-5	-			
7	J5-2	+			
	J5-1	-			
8	J5-4	+	(to customer ESTOP switch)	ESTOP	
	J5-3	-	-48 VDC		
--	J5-5		not used	not used	not used
--	J5-6				



**NOTE!** -48V is factory wired to the Digital Input #8 (-) terminal for your convenience and function predefined for ESTOP. Customer-furnished system ground applied to terminal Digital Input #8 (+) activates the ESTOP function. The ESTOP function shuts down and locks out the rectifiers or 400V DC input converters, opens the LVD's, and shuts down the optional -48V to +24V DC converters. When the ESTOP signal is removed, LVD's close (if battery present) and -48V to +24V DC converters restart. To restart the rectifiers or 400V DC input converters; turn input power to the rectifiers/converters OFF, wait 30 seconds or more (until the LEDs on the module extinguish), then turn input power to the rectifiers/converters ON.

**Table 5.2 Programmable Relay Outputs – IB2 Board**

Programmable Relay Output		IB2 Pin No.	Alarms Assigned to this Relay (Default)	Alarms Assigned to this Relay (Custom)	
1	NO	J6-5	The relays may be preprogrammed for specific functions. Refer to the configuration drawing (C-drawing) supplied with your system for your system's specific configuration.		
	COM	J6-3			
	NC	J6-1			
2	NO	J6-6			
	COM	J6-4			
	NC	J6-2			
3	NO	J7-5			
	COM	J7-3			
	NC	J7-1			
4	NO	J7-6			
	COM	J7-4			
	NC	J7-2			
5	NO	J8-5			
	COM	J8-3			
	NC	J8-1			
6	NO	J8-6			
	COM	J8-4			
	NC	J8-2			
7	NO	J9-5			
	COM	J9-3			
	NC	J9-1			
8	NO	J9-6			
	COM	J9-4			
	NC	J9-2			



**NOTE!** The relay assigned to “Critical Summary” alarm (relay 1 by default) will operate in the “Fail Safe Mode”. “Fail Safe Mode” means Relay 1 is de-energized during an alarm condition, opening the contacts between the C and NO terminals, and closing the contacts between the C and NC terminals.

The remaining 7 relays energize during an alarm condition, closing the contacts between the C and NO terminals, and opening the contacts between the C and NC terminals.

Refer to the configuration drawing (C-drawing) supplied with your system for your system’s specific relay labeling.

## 5.4.4 Optional EIB (Controller Extended Interface Board) Connections (if required) (Main Bay Only)



**NOTE!** The system may have one (1) or two (2) EIB boards installed.

Each optional EIB (Controller Extended Interface Board) provides additional connection points for voltage and current inputs, programmable relay outputs, and temperature probes. The EIB extended interface board is mounted inside the distribution cabinet. Refer to **Figure 30**.

### **Current Inputs, Voltage Inputs, and Programmable Relay Outputs**

Current input, voltage input, and relay output leads are connected to screw-type terminal blocks located on the optional EIB. Recommended torque for these connections is 2.2 in-lbs. Refer to **Figure 34** for terminal locations. Refer to **Table 3**, **Table 4**, and **Table 5** for pin-out information.

#### **Current Inputs**

Connect up to three (3) shunt inputs to the EIB. Observe proper polarity. Refer to **Figure 34** for terminal locations and **Table 3** for pin-out information.

Refer to the ACU+ Instructions (UM1M820BNA or UM1M820DNA400) or NCU Instructions (UM1M830BNA) and program the shunt input parameters.



**NOTE!** The shunt needs to be installed in the hot (-48V) bus. Connect the plus side of the shunt to the positive shunt input on the EIB. Connect the negative side of the shunt to the negative shunt input on the EIB.

#### **Voltage Inputs for Battery Block and Battery Midpoint Monitoring**

The controller can monitor battery blocks (12V blocks) or midpoint battery voltage of battery strings connected to the EIB. The EIB provides a total of eight (8) DC voltage inputs for these connections. An alarm is issued when either battery block voltage or battery midpoint voltage is abnormal. Refer to **Figure 34** for terminal locations and **Table 4** for pin-out information.

Refer to **Figure 33** for connection details. Refer to the ACU+ Instructions (UM1M820BNA or UM1M820DNA400) or NCU Instructions (UM1M830BNA) and program the following parameters.

- **Battery Block Monitoring**

Voltage Type: Set to "48 (Block 4)". This selects the EIB to monitor up to two (2) 48V battery strings with four (4) 12V blocks per string.

BlockVDiff(12V): This menu item appears if "48 (Block 4)" is selected above. Set to the alarm threshold for battery block monitoring per site requirements. The controller issues an alarm when any block voltage of any battery string has an abnormal value. The alarm is issued when the difference between any block voltage and a reference voltage is greater than the value of the block voltage difference setting.

Block In-Use: Set to the number of 12V battery blocks being used.

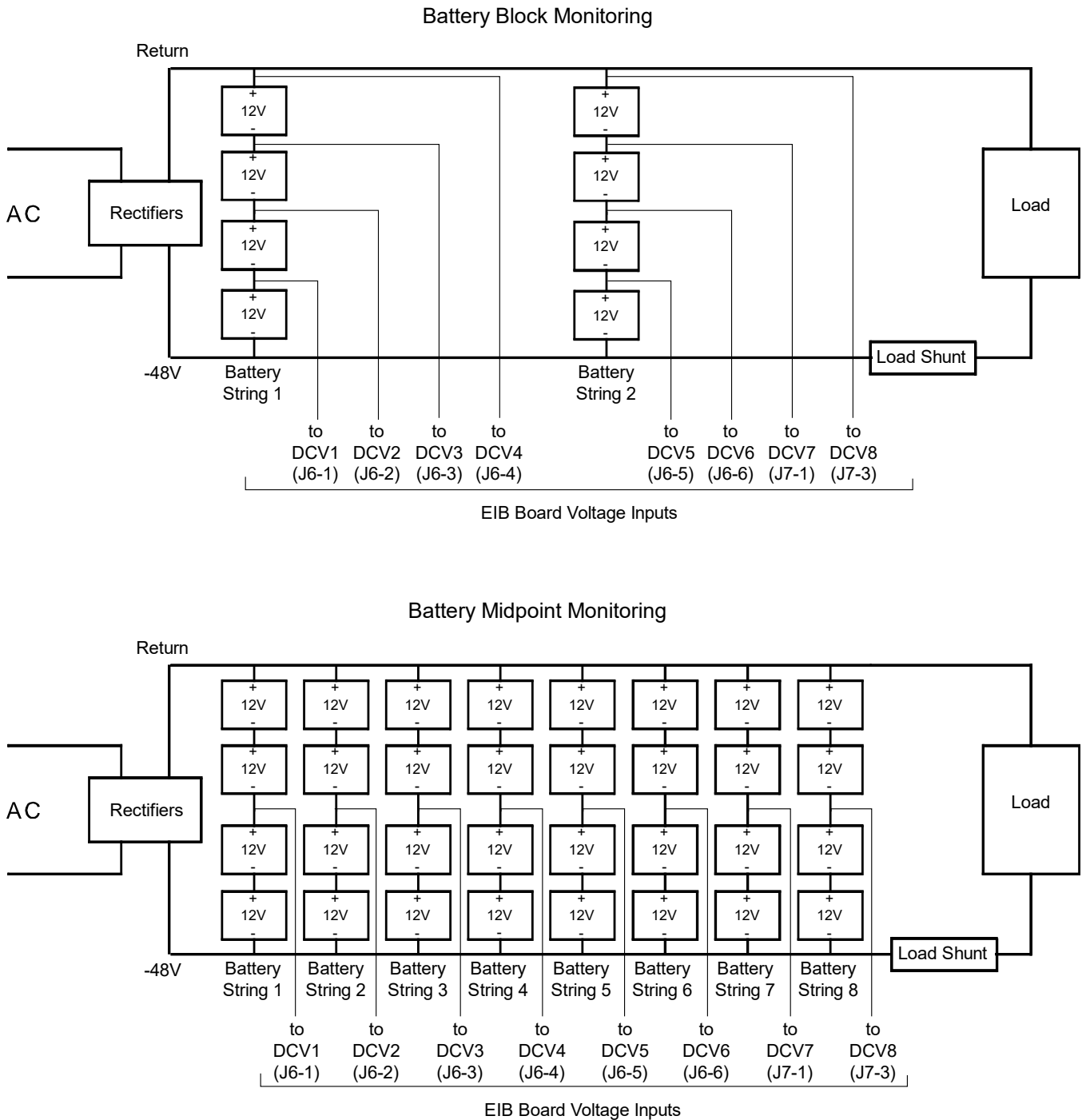
- **Midpoint Monitoring**

Voltage Type: Set to "Midpoint". This selects the EIB to monitor the midpoint voltage of up to eight (8) battery strings.

BlockVDiff(Mid): This menu item appears if "Midpoint" is selected above. Set to the alarm threshold for battery midpoint monitoring per site requirements. The controller issues an alarm when any battery midpoint voltage of any battery string has an abnormal value. The alarm is issued when the difference between any battery midpoint voltage and a reference voltage is greater than the value of the block voltage difference setting.

Block In-Use: Set to number of 12V battery blocks being used.

**Figure 5.25 Sample Battery Block or Battery Midpoint Monitoring Connections**



### **Programmable Relay Outputs**

The EIB provides five (5) programmable alarm relays with dry Form-C contacts. Connect up to five (5) relay outputs to the EIB. Refer to **Figure 34** for terminal locations and **Table 4** for pin-out information.

Refer to the ACU+ Instructions (UM1M820BNA or UM1M820DNA400) or NCU Instructions (UM1M830BNA) for programming information.

Relay Ratings: Refer to the following.

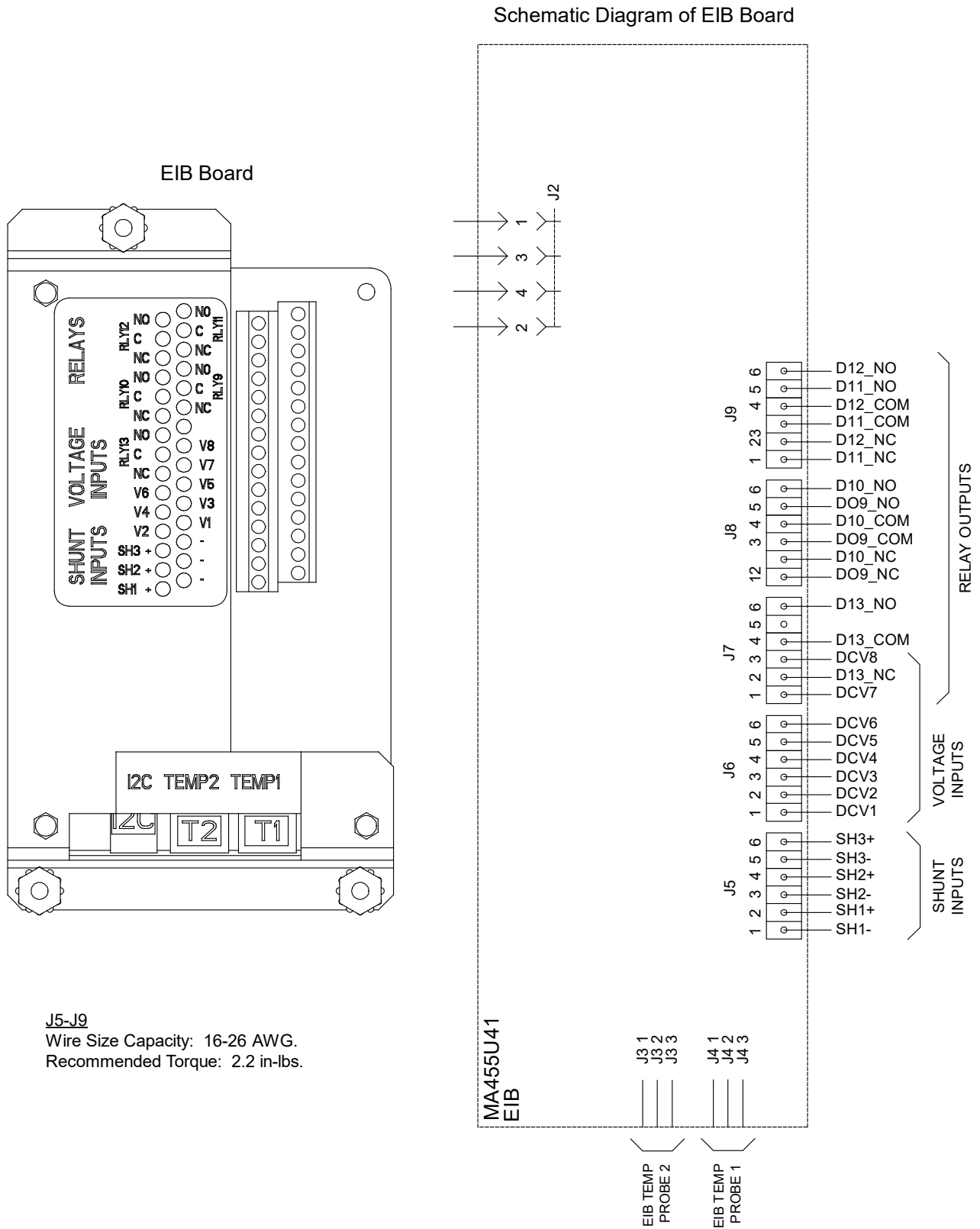
- a) Steady State: 0.5 A @ 60V DC; 1.0 A @ 30V DC.
- b) Peak: 3 A @ 30V DC.

The relays may be preprogrammed for specific functions. Refer to the configuration drawing (C-drawing) supplied with your system for your system's specific configuration.

### **Temperature Probes**

Temperature probes can be connected to the optional EIB (Controller Extended Interface Board) mounted inside the distribution cabinet. Refer to "Temperature Probes" on page 49.

Figure 5.26 EIB (Extended Interface Board) Connections



**Table 5.3 Shunt Inputs – EIB**

Shunt Input	EIB Pin No.		Factory Wiring	Default Function	Customer Defined Function
Sh1	J5-2	+	--	none	
	J5-1	-	--		
Sh2	J5-4	+	--	none	
	J5-3	-	--		
Sh3	J5-6	+	--	none	
	J5-5	-	--		

**Table 5.4 Voltage Inputs – EIB**

Voltage Input	EIB Pin No.	Default Function
1	J6-1	Battery Block Monitoring
2	J6-2	
3	J6-3	
4	J6-4	
5	J6-5	
6	J6-6	
7	J7-1	
8	J7-3	

**Table 5.5 Programmable Relay Outputs – EIB**

Programmable Relay Output		EIB Pin No.	Alarms Assigned to this Relay (Default)	Alarms Assigned to this Relay (Custom)			
9	NO	J8-5	The relays may be preprogrammed for specific functions. Refer to the configuration drawing (C-drawing) supplied with your system for your system's specific configuration.				
	COM	J8-3					
	NC	J8-1					
10	NO	J8-6		The relays may be preprogrammed for specific functions. Refer to the configuration drawing (C-drawing) supplied with your system for your system's specific configuration.			
	COM	J8-4					
	NC	J8-2					
11	NO	J9-5			The relays may be preprogrammed for specific functions. Refer to the configuration drawing (C-drawing) supplied with your system for your system's specific configuration.		
	COM	J9-3					
	NC	J9-1					
12	NO	J9-6				The relays may be preprogrammed for specific functions. Refer to the configuration drawing (C-drawing) supplied with your system for your system's specific configuration.	
	COM	J9-4					
	NC	J9-2					
13	NO	J7-6					The relays may be preprogrammed for specific functions. Refer to the configuration drawing (C-drawing) supplied with your system for your system's specific configuration.
	COM	J7-4					
	NC	J7-2					



**NOTE!** The relays energize during an alarm condition, closing the contacts between the C and NO terminals, and opening the contacts between the C and NC terminals.

Refer to the configuration drawing (C-drawing) supplied with your system for your system's specific relay labeling.

### 5.4.5 Optional SM-DU+ and Shunt Interface Board

The optional SM-DU+ and Shunt Interface Board provides connections for up to twenty-five (25) shunt inputs. Inputs are factory connected to any distribution positions/devices containing shunts. Refer to **Figure 35**.

**Procedure**

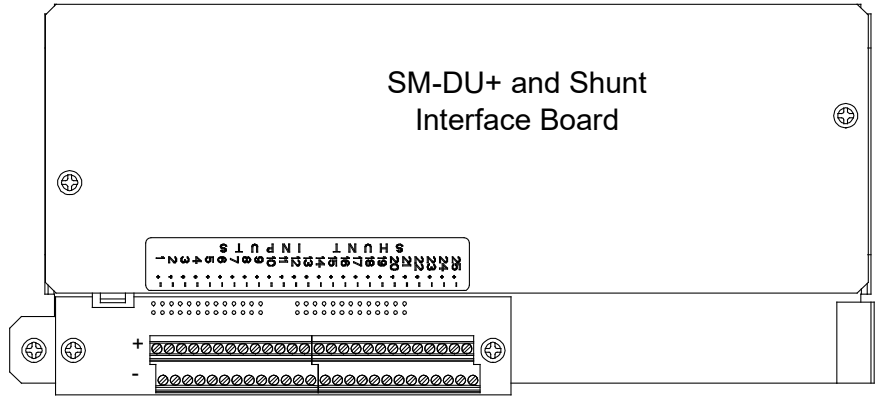
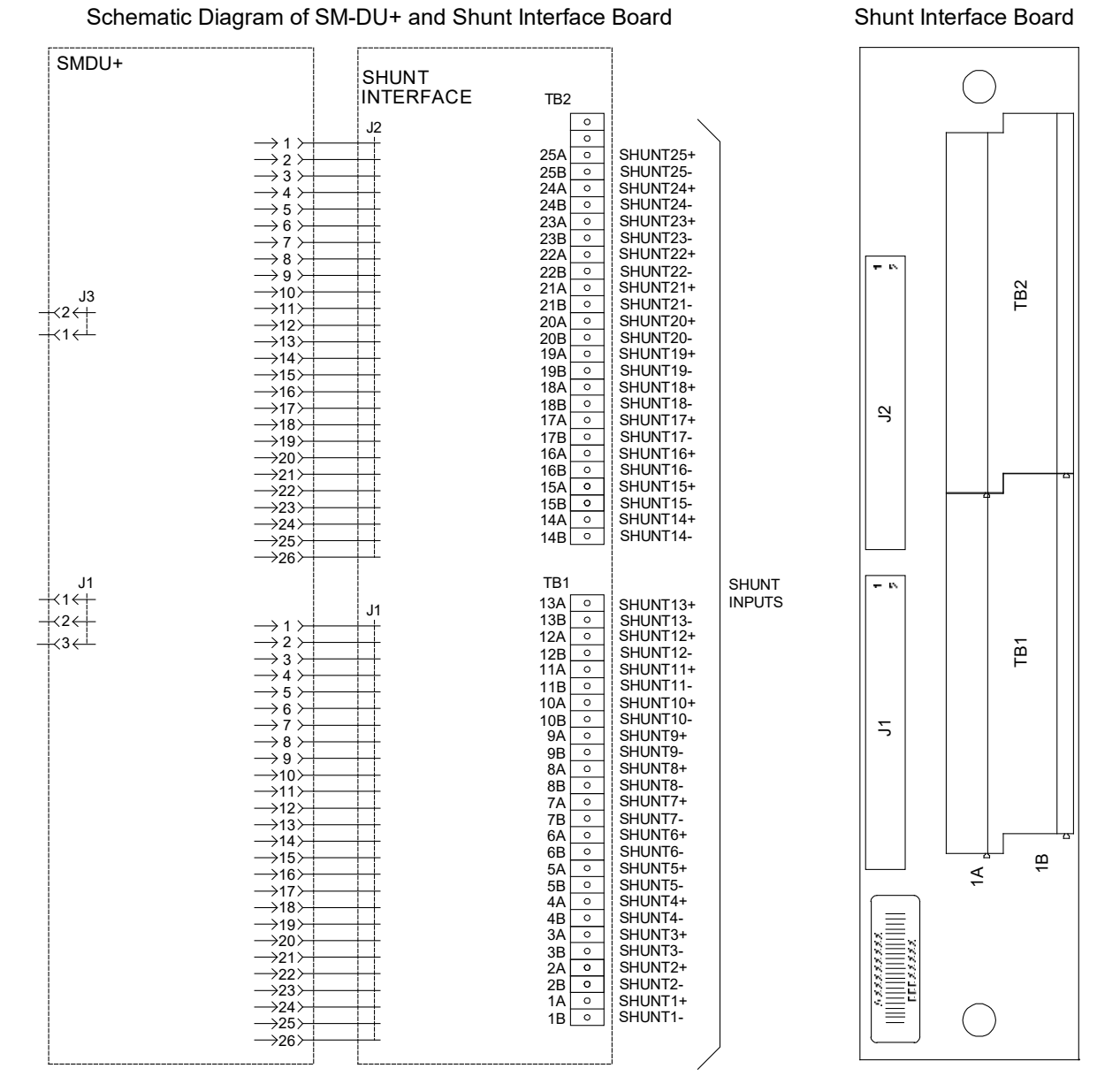
Current Inputs: Connect up to twenty-five (25) shunt inputs to the Shunt Interface Board. Observe proper polarity. Note that some inputs may be factory connected, depending on distribution devices installed. Refer to the ACU+ Instructions (UM1M820BNA or UM1M820DNA400) or NCU Instructions (UM1M830BNA) for programming information for the unused inputs.



**NOTE!** The shunt needs to be installed in the hot (-48V) bus. Connect the plus side of the shunt to the positive shunt input on the SM-DU+. Connect the negative side of the shunt to the negative shunt input on the SM-DU+.



Figure 5.27 SM-DU+ and Shunt Interface Board Connections



**TB1 - TB2**  
 Wire Size Capacity: 16-26 AWG.  
 Recommended Torque: 2.2 in-lbs.

## 5.4.6 Connecting a Device or System to the Controller's CAN Bus

A supporting device or system may be connected to the Controller's CAN Port. Refer to **Figure 31** for location. Refer to **Table 6** for pin-outs. Refer also to the external device's or system's instruction manual.

### General Procedure

1. Remove the CAN termination plug from the bottom CAN connector on the System Interface circuit card of the last bay (see **Figure 31** for location). Connect the device or system to the bottom CAN connector on the System Interface circuit card of the last bay. Refer to **Table 6** for pin-outs. Ensure that the last device on the controller's CAN bus has a CAN termination plug. Refer also to the external device's or system's instruction manual.

### Optional SM-Temp Module Procedure

The analog output of the SM-Temp Module may be connected to a controller's temperature port input. In lieu of connecting the analog output of the SM-TEMP module to a temperature port input, the SM-TEMP module can simply be connected at the end of the Controller's CAN Bus (for system's equipped with an ACU+, requires ACU+ version 3.02 or later). Refer to the SM-Temp Module Instructions (UM547490) for details.

### Connecting the SM-Temp Module to the Controller's CAN Bus

1. Remove the CAN termination plug from the bottom CAN connector on the System Interface circuit card of the last bay. Connect the SM-Temp Module CAN bus to the bottom CAN connector on the System Interface circuit card of the last bay. Refer to **Table 6** for pin-outs. Ensure the last SM-Temp Module (or if only one) has a CAN termination strap as shown in the SM-Temp Module Instructions (UM547490).

**Table 5.6 CAN Connections**

Controller CAN Port (RJ-45)		SM-Temp Module CAN Port Pin Number
Pin Number	Function	
1	CAN L	TB1-5 (CAN L)
2	CAN H	TB1-3 (CAN H)
3	--	--
4	--	--
5	--	--
6	--	--
7	--	--
8	--	--

## 5.5 Make Controller Ethernet Connection (if required)

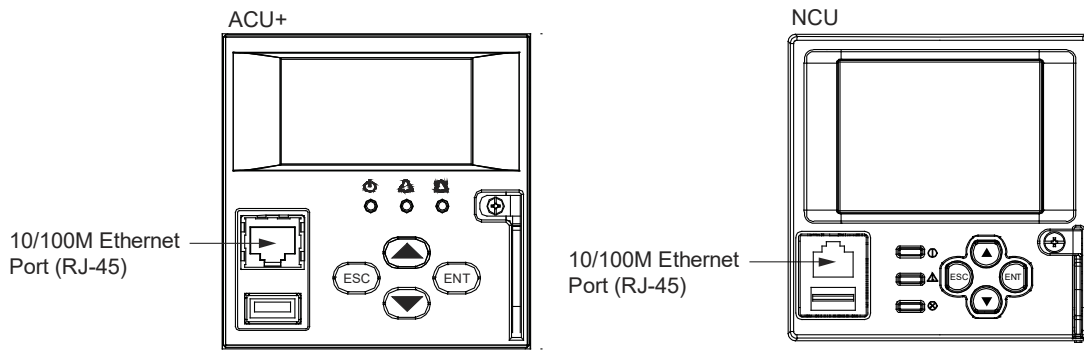
If the Web Interface will be used, connect to the Ethernet port on the front of the Controller. Location is shown in **Figure 36**.

Refer to *External Alarm, Reference, Monitoring, and Control Connections* in the MAKING ELECTRICAL CONNECTIONS section of the Installation Instructions (IM582127000) for Ethernet connection details.



**NOTE!** You can access the Web pages of the power system locally by using a "crossover" or "straight" cable connected directly between your PC and the controller.

**Figure 5.28** Controller Ethernet Port



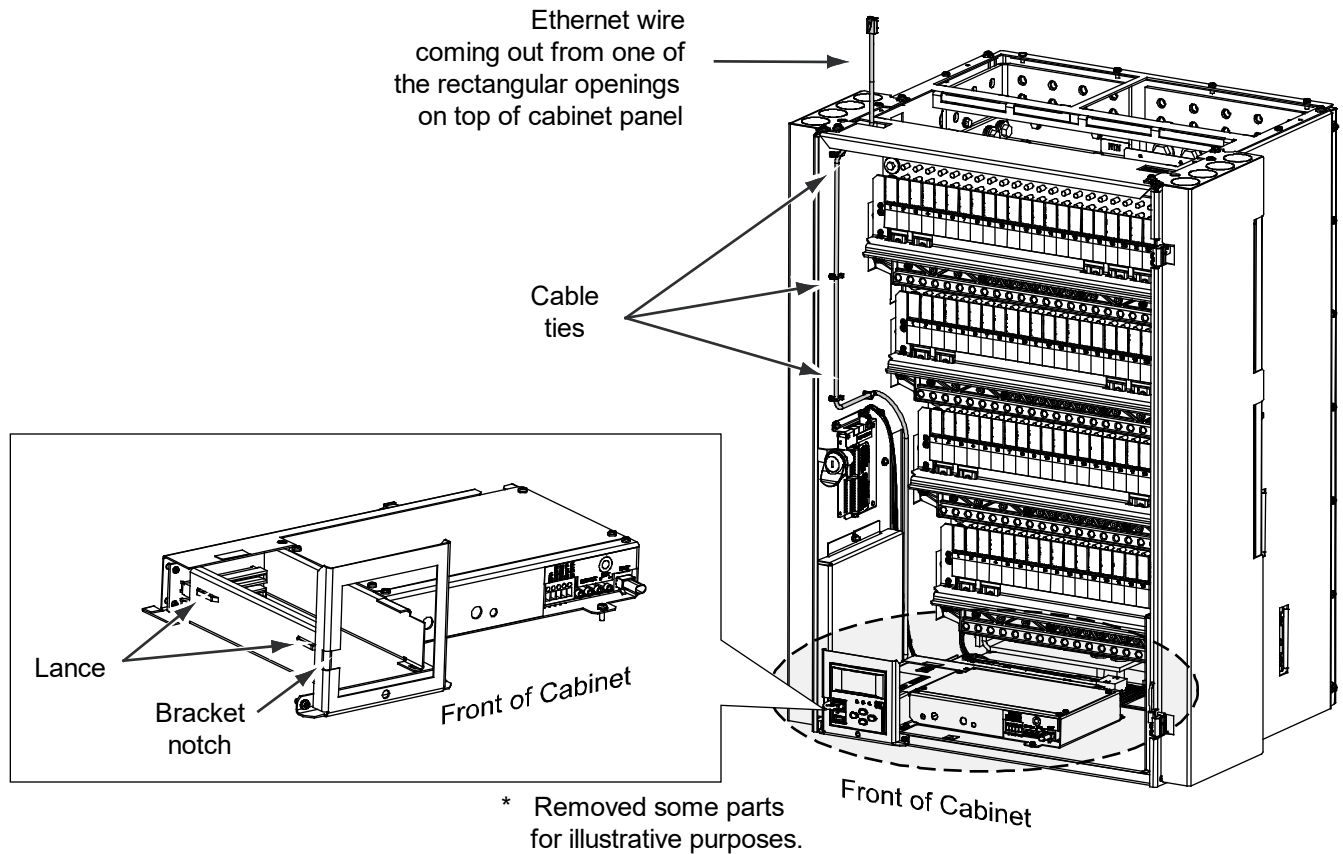
**NOTE!** NCU ONLY: If your system has an IB4 board, DO NOT connect your Local Area Network (LAN) to the NCU front Ethernet port. See "NCU Controller Second Ethernet Port Connection (if IB4 board furnished)" on page 63.

### Ethernet Connection through the Power System

The Ethernet cable can be routed from the notch on the left side of the bracket. It goes through the lances on the chassis, then goes up to be bundled with the harness and all other customer alarm and signal cables.

The existing cable ties can also be used to secure the Ethernet cable as it goes up to the top panel.

**Figure 5.29 Network Connection through Power System**



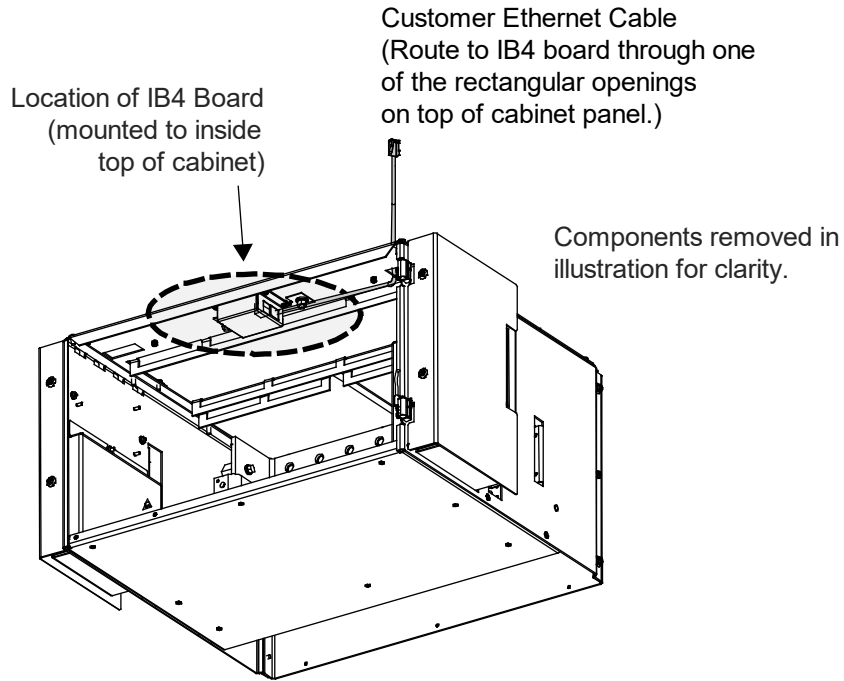
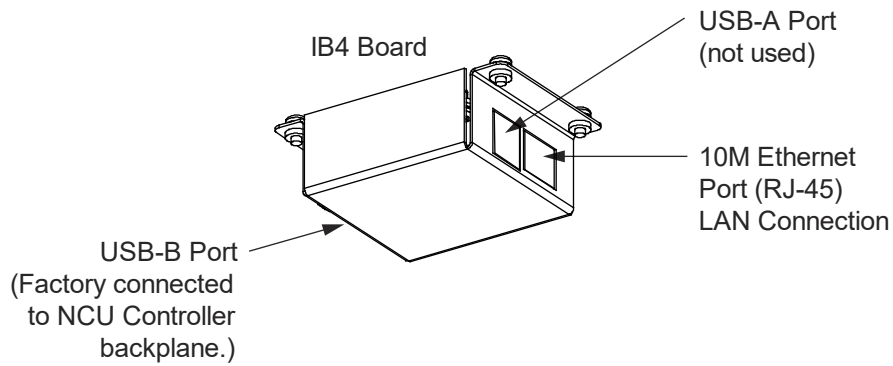
**NCU Controller Second Ethernet Port Connection (if IB4 board furnished)**

Your system may be furnished with an IB4 board connected to the NCU backplane via a factory furnished and connected cable. The IB4 board provides a second Ethernet port. The Ethernet port located on the NCU Controller’s front panel can ONLY be used to connect a computer directly to the NCU. The Ethernet port located on the IB4 board can be used to connect the NCU to your Local Area Network (LAN).



**NOTE!** If your system has an IB4 board, DO NOT connect your Local Area Network (LAN) to the NCU front Ethernet port.

**Figure 5.30 IB4 Board NCU Controller Second Ethernet Port**



List 21 Distribution Cabinet  
(others similar)

## 5.6 Make Bay-to-Bay Communications Cable Connections

Refer to *Bay-to-Bay Communications Cable Connections* in the MAKING ELECTRICAL CONNECTIONS section of the Installation Instructions (IM582127000) for a complete procedure.

The bays are interconnected using standard Cat5 communications cables. Supplemental bays are provided with a 25' cable. Refer to **Figure 39** for a bay-to-bay cable diagram.



**NOTE!** Maximum combined length of the Cat5 communications cables is 328' (100m) per industry standards.

## 5.7 Installing Bay-to-Bay Busbars (582127000 List 1 with List 2 / List 3) (for system mounted in a relay rack)

Refer to *Installing Bay-to-Bay Busbars (582127000 List 1 with List 2 / List 3)* in the MAKING ELECTRICAL CONNECTIONS section of the Installation Instructions (IM582127000) for a complete procedure.

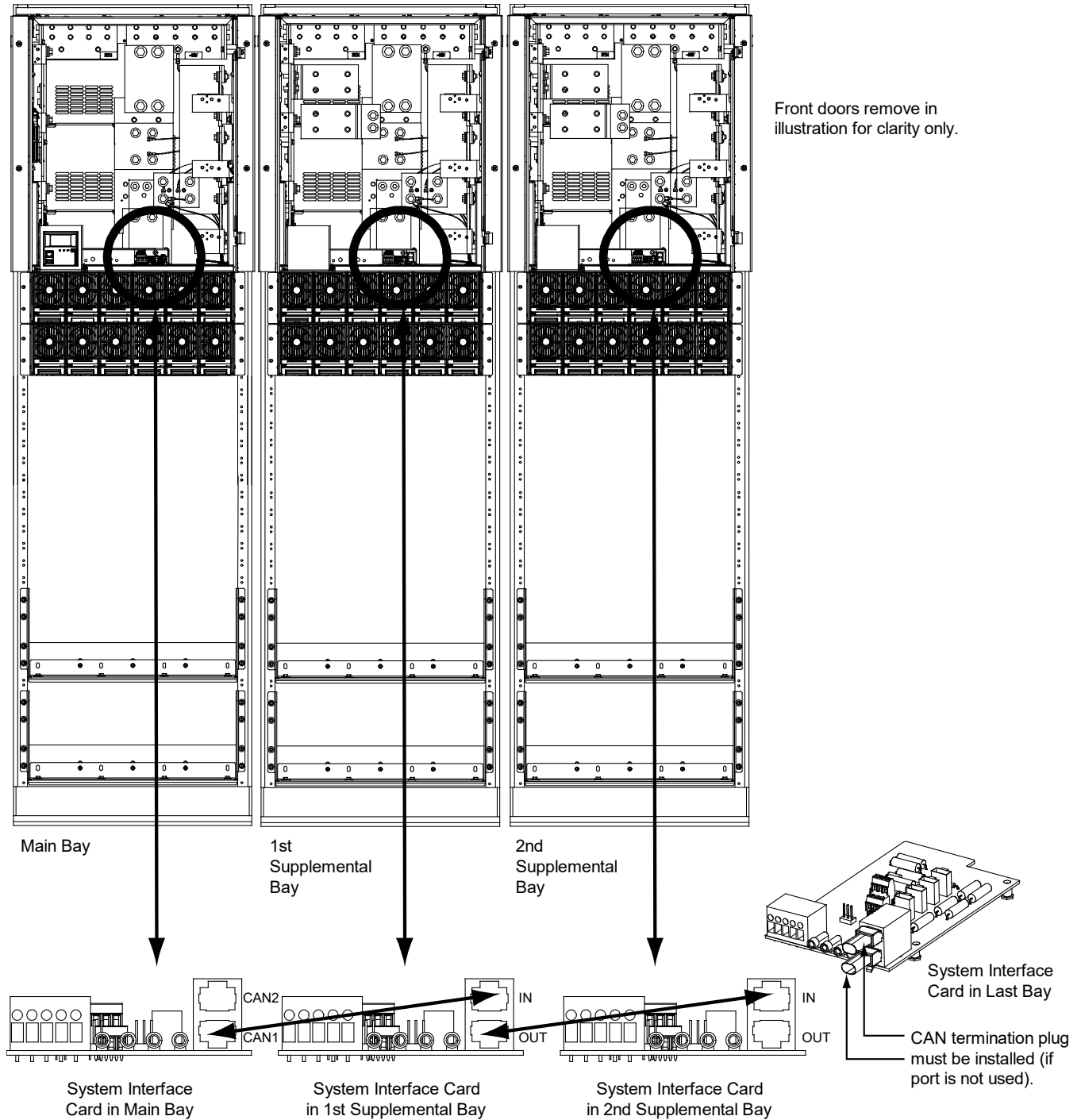
When 582127000 List 3 and/or List 2 is ordered, bay-to-bay busbars and hardware are provided for system power connections between distribution cabinets. Interconnect per **Figure 40**.

## 5.8 Installing Bay-to-Bay Busbars (582127000 List 1 with List 7 / List 8) (for system mounted in an enclosure)

Refer to *Installing Bay-to-Bay Busbars (582127000 List 1 with List 7 / List 8)* in the MAKING ELECTRICAL CONNECTIONS section of the Installation Instructions (IM582127000) for a complete procedure.

When 582127000 List 8 and/or List 7 is ordered, bay-to-bay busbars and hardware are provided for system power connections between distribution cabinets. Interconnect per **Figure 41**.

Figure 5.31 Bay-to-Bay Communications Cable Connections



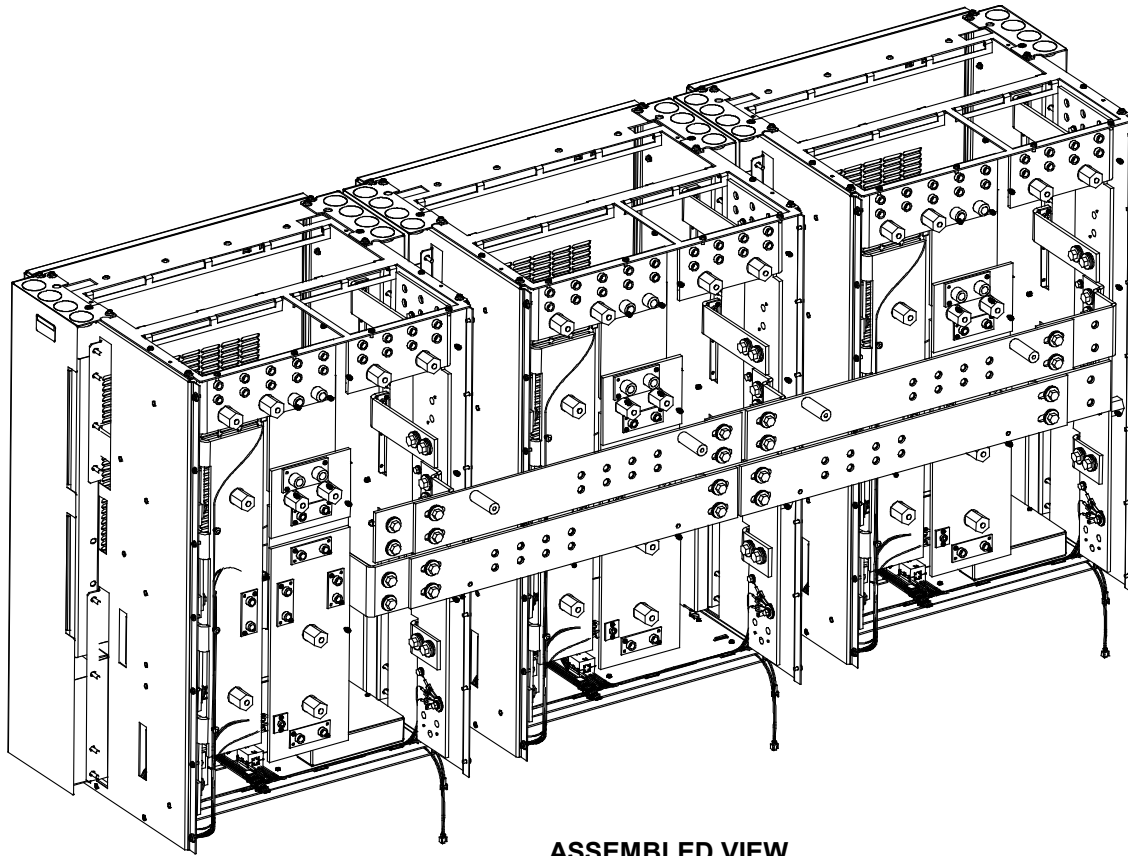
Use standard Cat5 communications cables.

1. Remove terminating plug from bottom connector on the System Interface Circuit Card installed in the Main Bay and place in bottom connector on the System Interface Circuit Card in the last bay.
2. Connect the bottom connector on the System Interface Circuit Card installed in the Main Bay to the top connector on the System Interface Circuit Card installed in the 1st Supplemental Bay.
3. Connect the bottom connector on the System Interface Circuit Card installed in the 1st Supplemental Bay to the top connector on the System Interface Circuit Card installed in the 2nd Supplemental Bay.

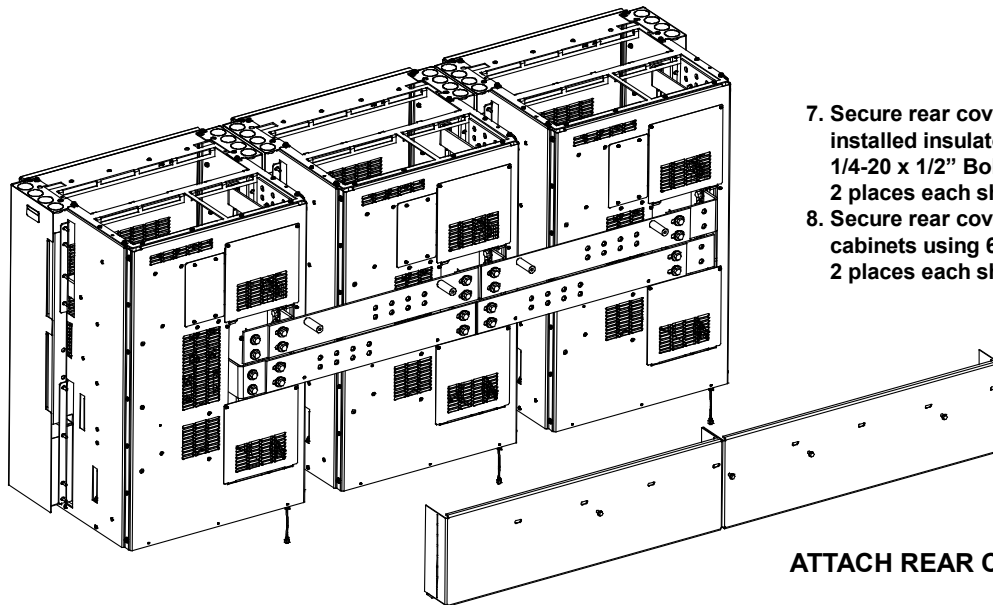




Figure 40 Installing Bay-to-Bay Busbars (List 2 and 3 Only) (for system mounted in a relay rack) (cont'd from previous page)



**ASSEMBLED VIEW**

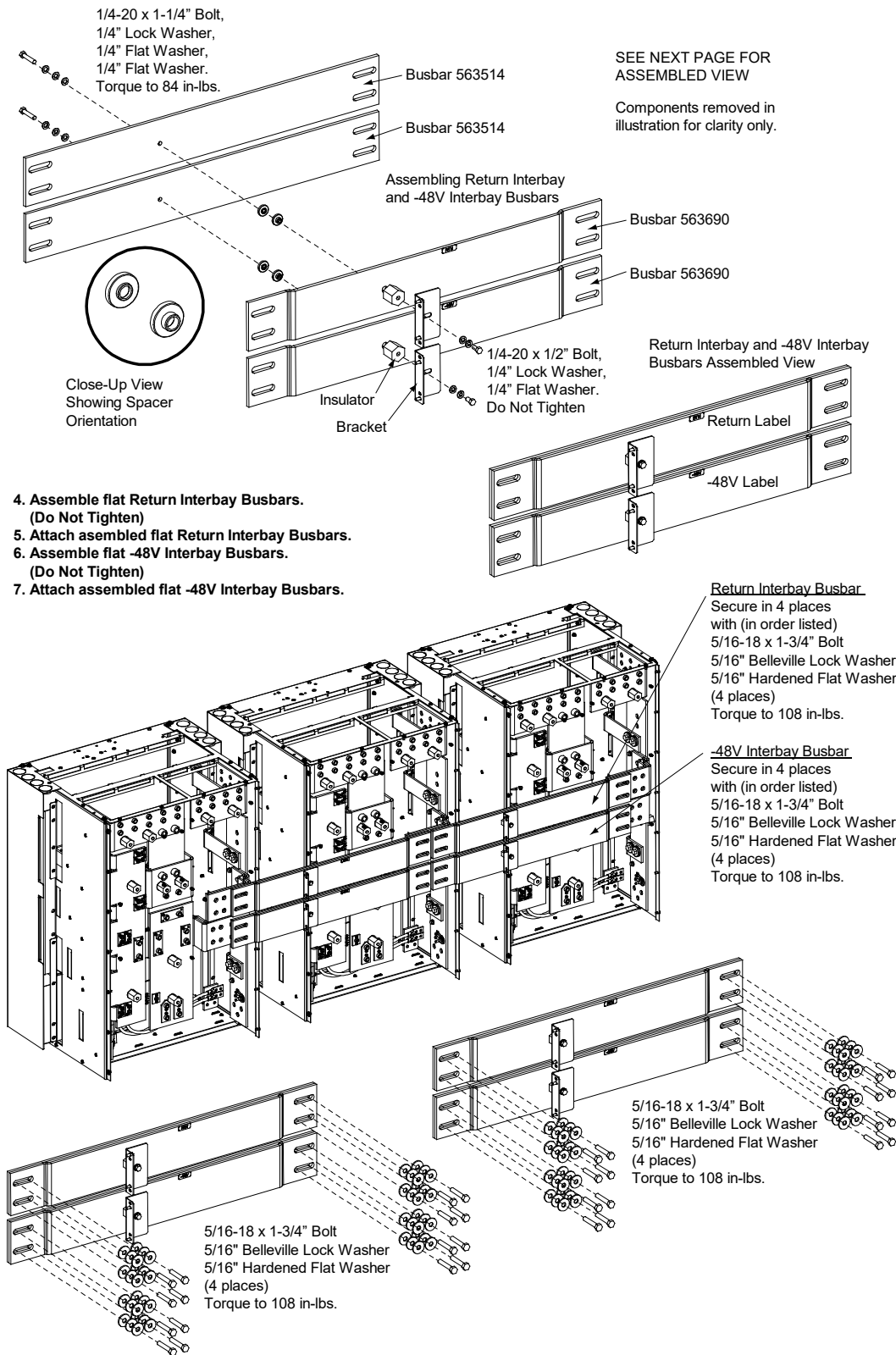


7. Secure rear cover shields to previously installed insulator standoffs using 1/4-20 x 1/2" Bolt and 1/4" Flat Washer, 2 places each shield.
8. Secure rear cover shields to distribution cabinets using 6-32 x 3/8" screws, 2 places each shield.

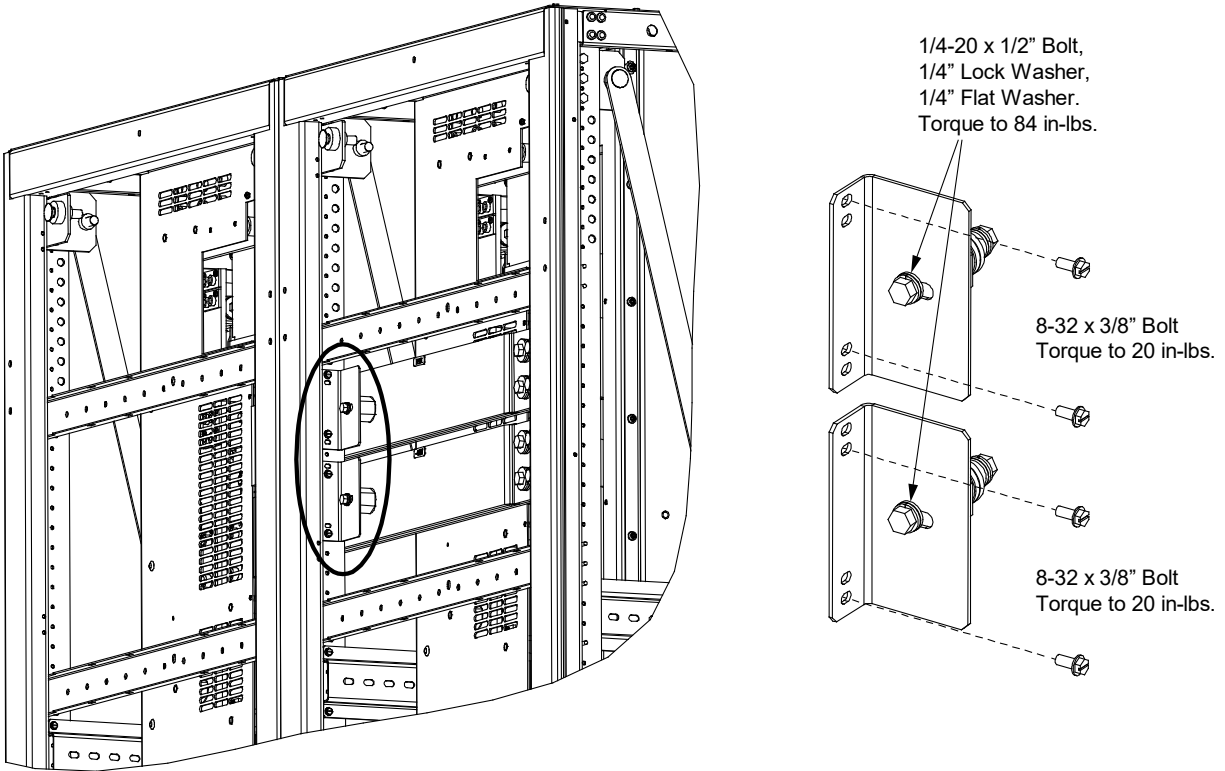
**ATTACH REAR COVER SHIELDS**



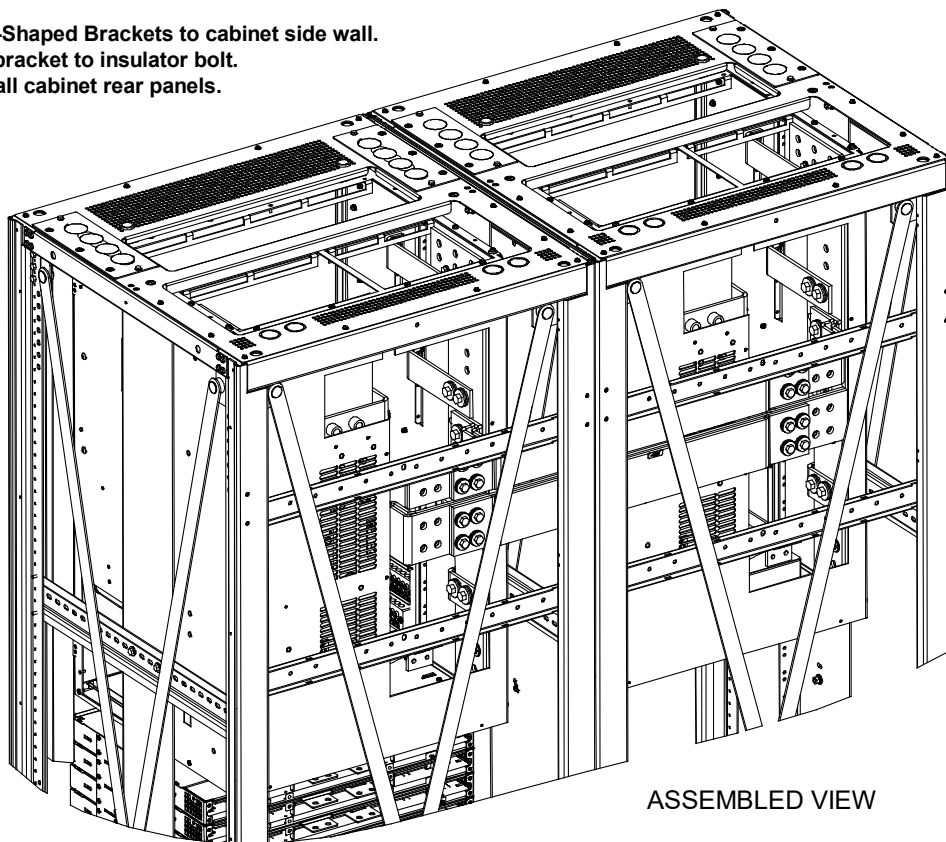
**Figure 41 Installing Bay-to-Bay Busbars (List 7 and 8 Only) (for system mounted in an enclosure) (cont'd from previous page, cont'd on next page)**



**Figure 41** Installing Bay-to-Bay Busbars (List 7 and 8 Only) (for system mounted in an enclosure) (cont'd from previous page)



- 8. Attach L-Shaped Brackets to cabinet side wall.
- 9. Tighten bracket to insulator bolt.
- 10. Re-Install cabinet rear panels.



## 5.9 Connecting Converter Output Cables 582127000 List 60



**NOTE!** *These connections are factory made for shelves factory installed. The connection must be made if a field expansion shelf is installed.*

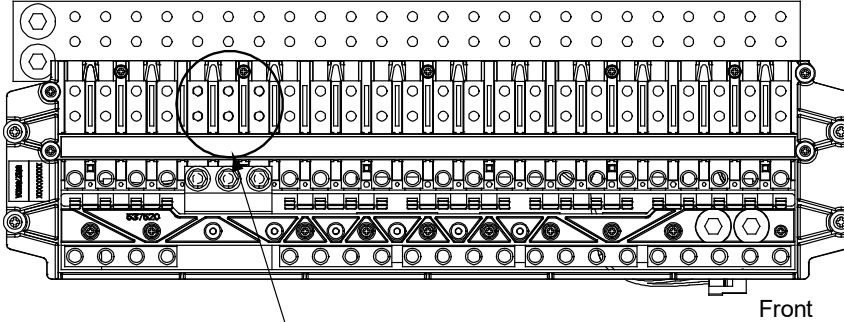
Refer to *Connecting Converter Output Cables 582127000 List 60* in the MAKING ELECTRICAL CONNECTIONS section of the Installation Instructions (IM582127000) for complete procedures.

Refer to **Figure 42** to connect the converter output cables between the dual voltage distribution panel and the rectifier/converter module mounting assembly Spec. No. 588705300.

**Figure 5.34** Installing Converter Output Cables (cont'd on next page)

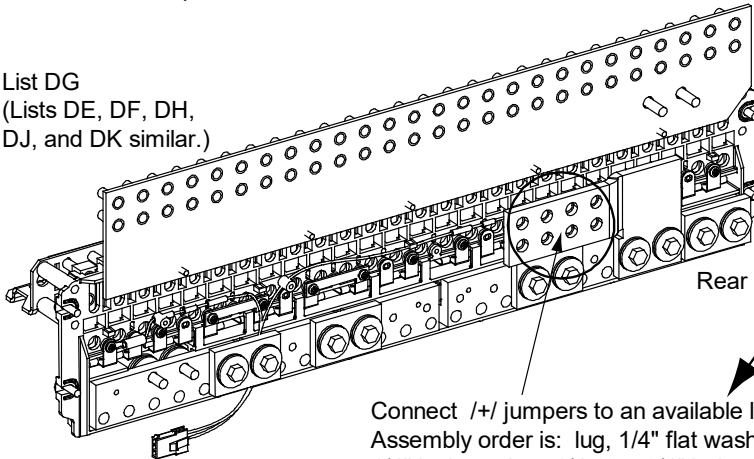
### Dual Voltage Distribution Panel

List DA (Lists DB, DC, and DD similar.)



Connect +/- jumpers to an available landing here.  
 Assembly order is: lug, 1/4" flat washer,  
 1/4" lock washer, 1/4-20 x 3/4" bolt.  
 Torque to 84 in-lbs.

List DG  
 (Lists DE, DF, DH,  
 DJ, and DK similar.)



Connect +/- jumpers to an available landing here.  
 Assembly order is: lug, 1/4" flat washer,  
 1/4" lock washer, 1/4-20 x 3/4" bolt.  
 Torque to 84 in-lbs.

Lugs may be mounted  
 back to back.



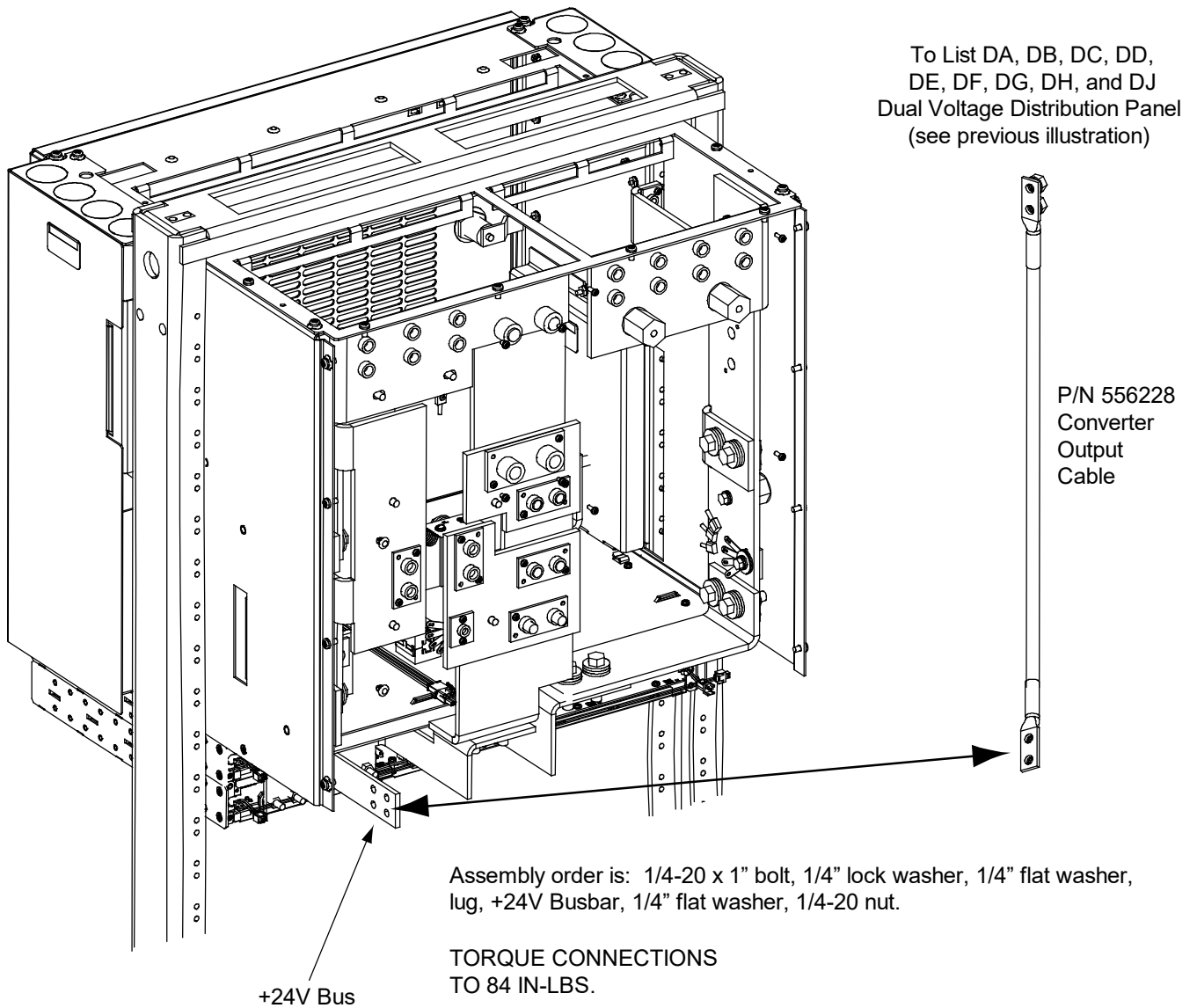
To List DA,  
 DB, DC, DD,  
 DE, DF, DG,  
 DH, and DJ  
 Dual Voltage  
 Distribution Panel

P/N 556228  
 Converter  
 Output Cable

This end is connected to  
 rectifier/converter shelf  
 +24V bus (see next  
 illustration).

Hardware provided  
 with Converter Option Kit.

Figure 42 Installing Converter Output Cables (cont'd from previous page, cont'd on next page)



## 5.10 Make Load Connections

Refer to *Load Connections* in the MAKING ELECTRICAL CONNECTIONS section of the Installation Instructions (IM582127000) for complete procedures.

Loads are connected to the various distribution panels located inside the distribution cabinet. See Figure 43 through Figure 65.

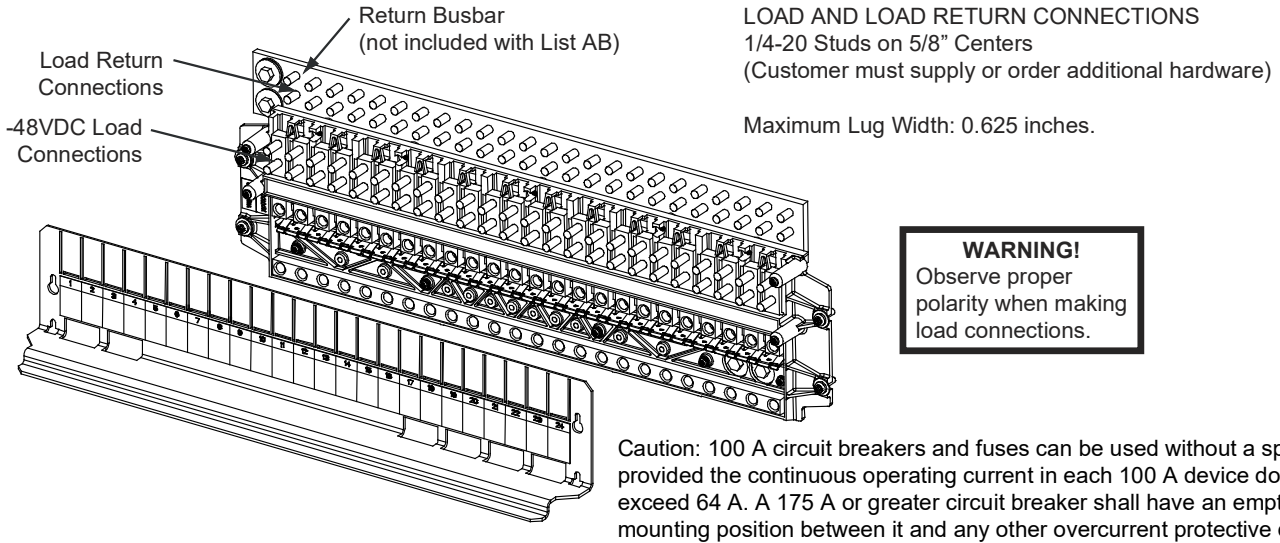
### 5.10.1 Recommended Torques

- 72 in-lbs for 1/4-inch hardware (when using standard flat and lock washer).
- 300 in-lbs for 3/8-inch hardware (when using standard flat and lock washer).



### 5.10.2 Load Connections to Single Voltage Distribution Panels

**Figure 5.35** List AA: -48V Distribution Panel (with Return Busbar) and List AB: -48V Distribution Panel (without Return Busbar), (24) Bullet/TPS/TLS Circuit Breaker/Fuse Positions



**Figure 5.36** List AC: -48V Distribution Panel (with Return Busbar) and List AD: -48V Distribution Panel (without Return Busbar), (4) GJ/218 Circuit Breaker Positions

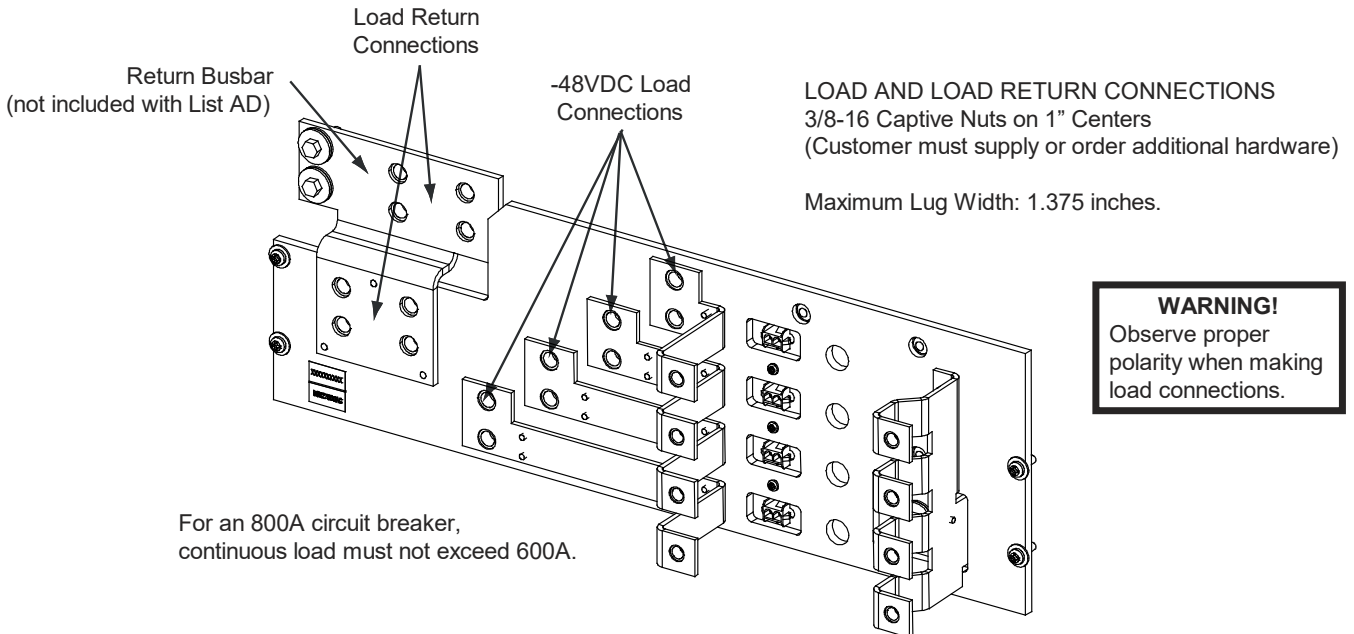


Figure 5.37 List AE: -48V Distribution Panel, (2) TPH Fuse Positions (without Shunts) (without Return Busbar)

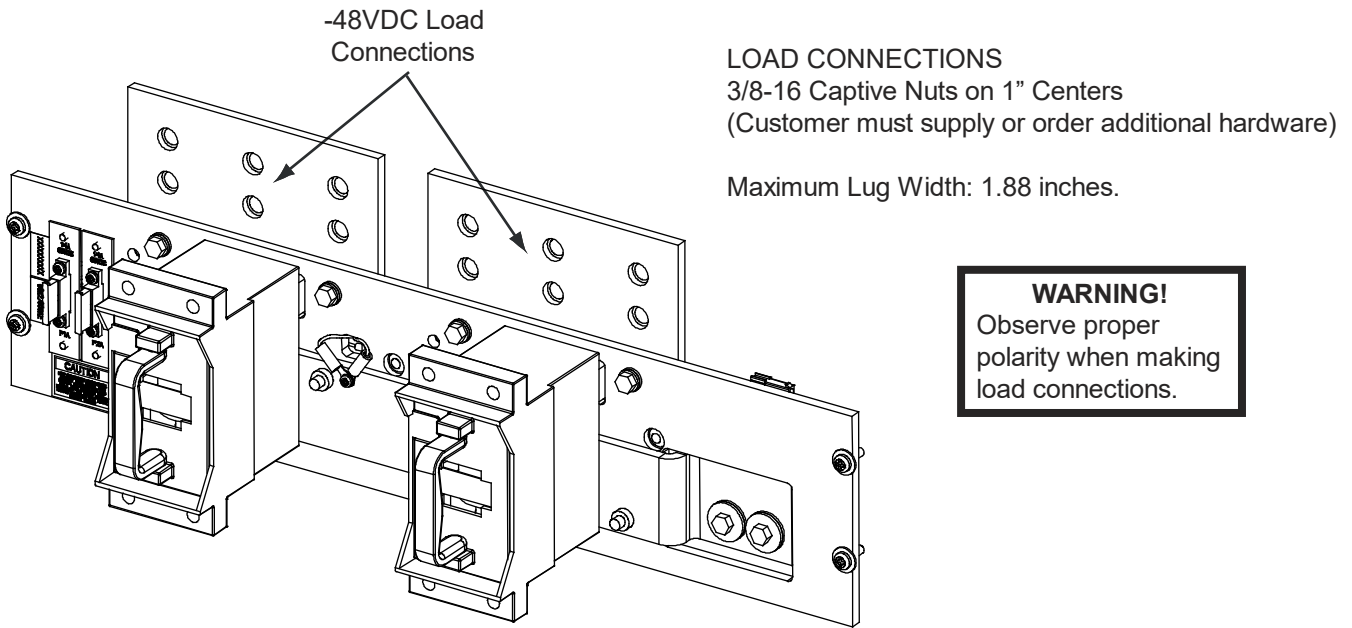


Figure 5.38 List AF: -48V Distribution Panel, (2) TPH Fuse Positions (with Shunts) (without Return Busbar)

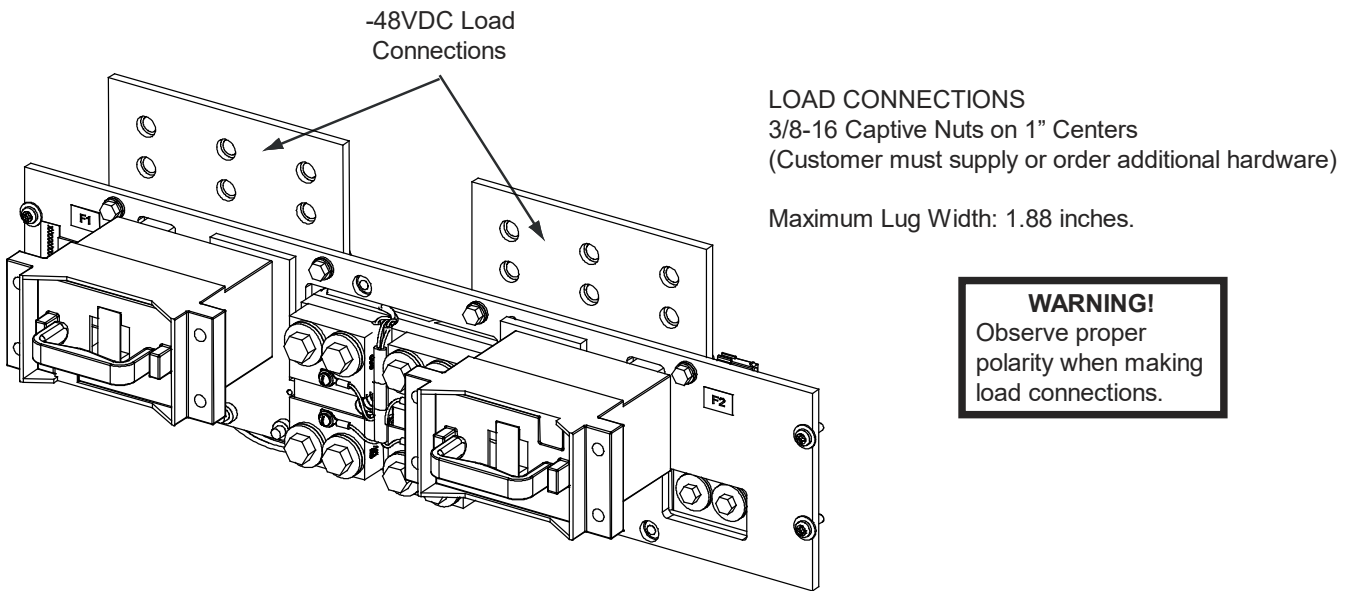


Figure 5.39 List AG: -48V Distribution Panel, (4) TPH Fuse Positions (without Shunts) (without Return Busbar)

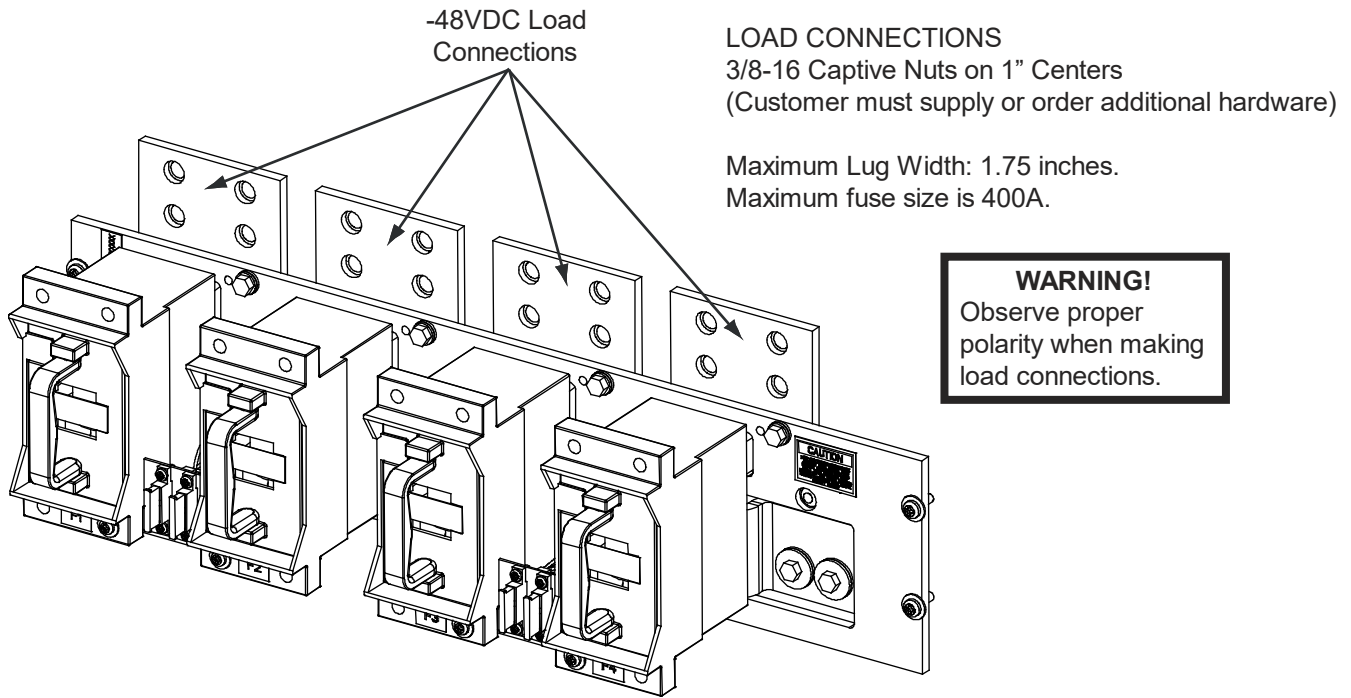


Figure 5.40 List AH: -48V Distribution Panel, (4) TPH Fuse Positions (with Shunts) (without Return Busbar)

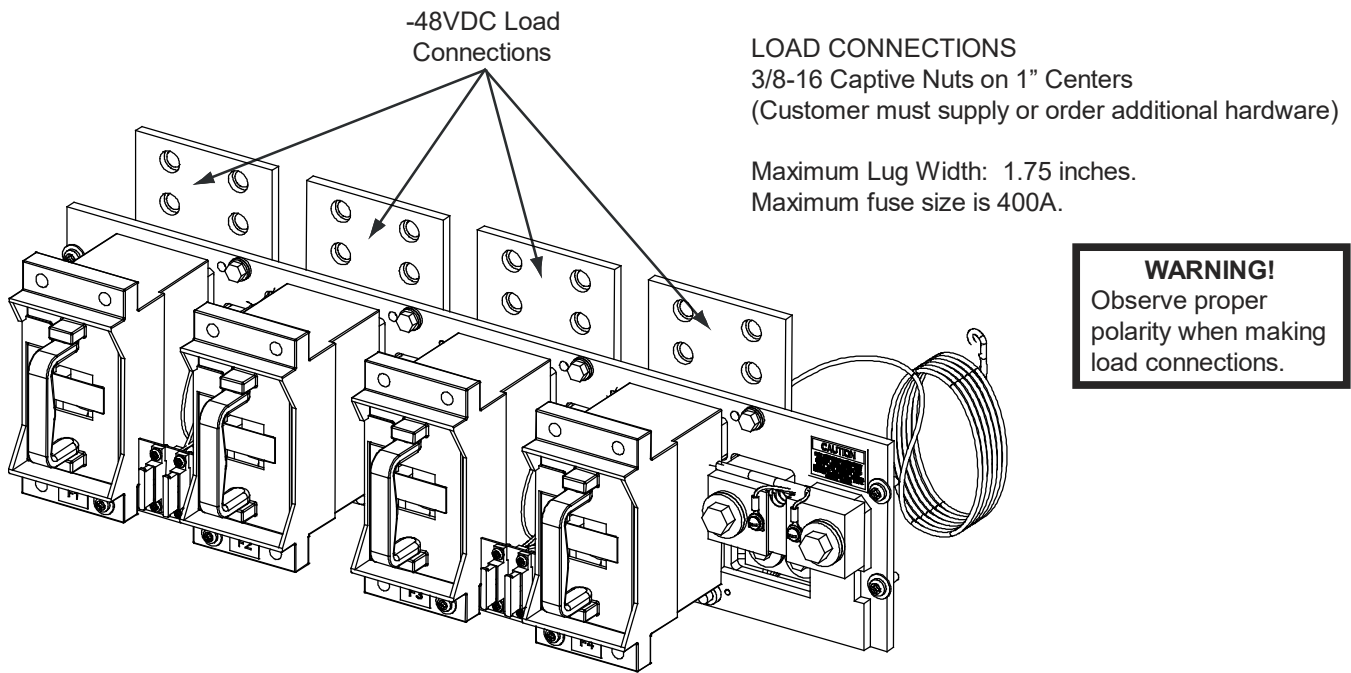


Figure 5.41 List AJ: -48V Distribution Panel, (4) TPL-B Fuse Positions (without Shunts) (without Return Busbar)

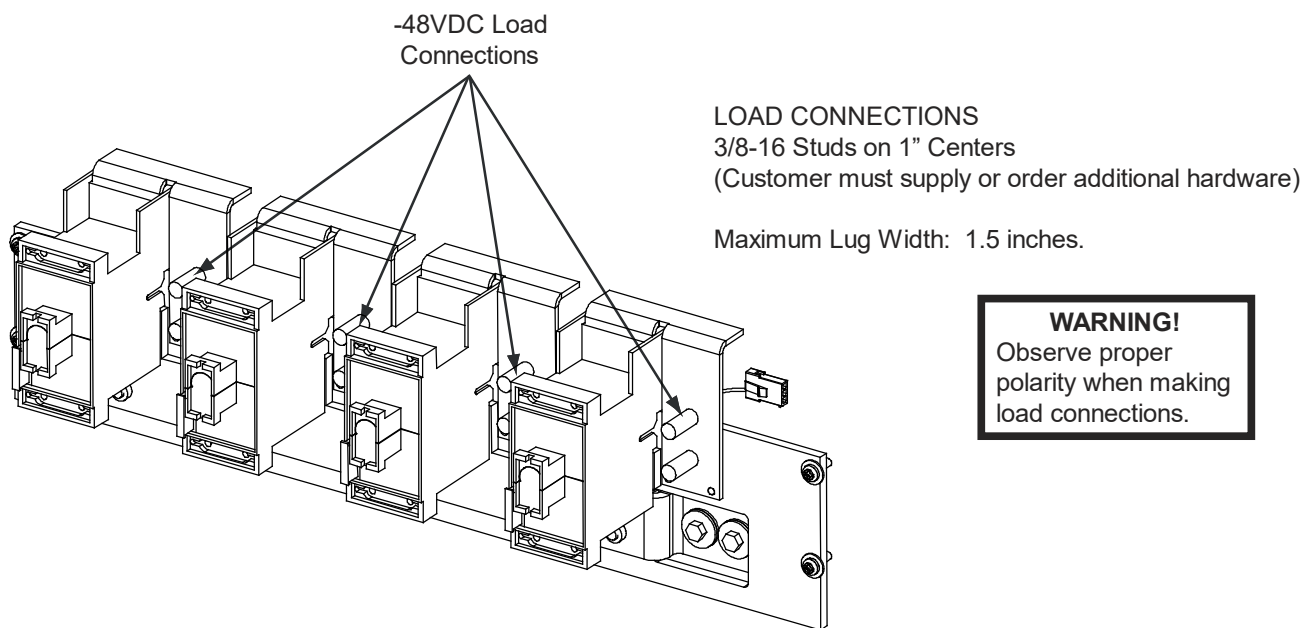
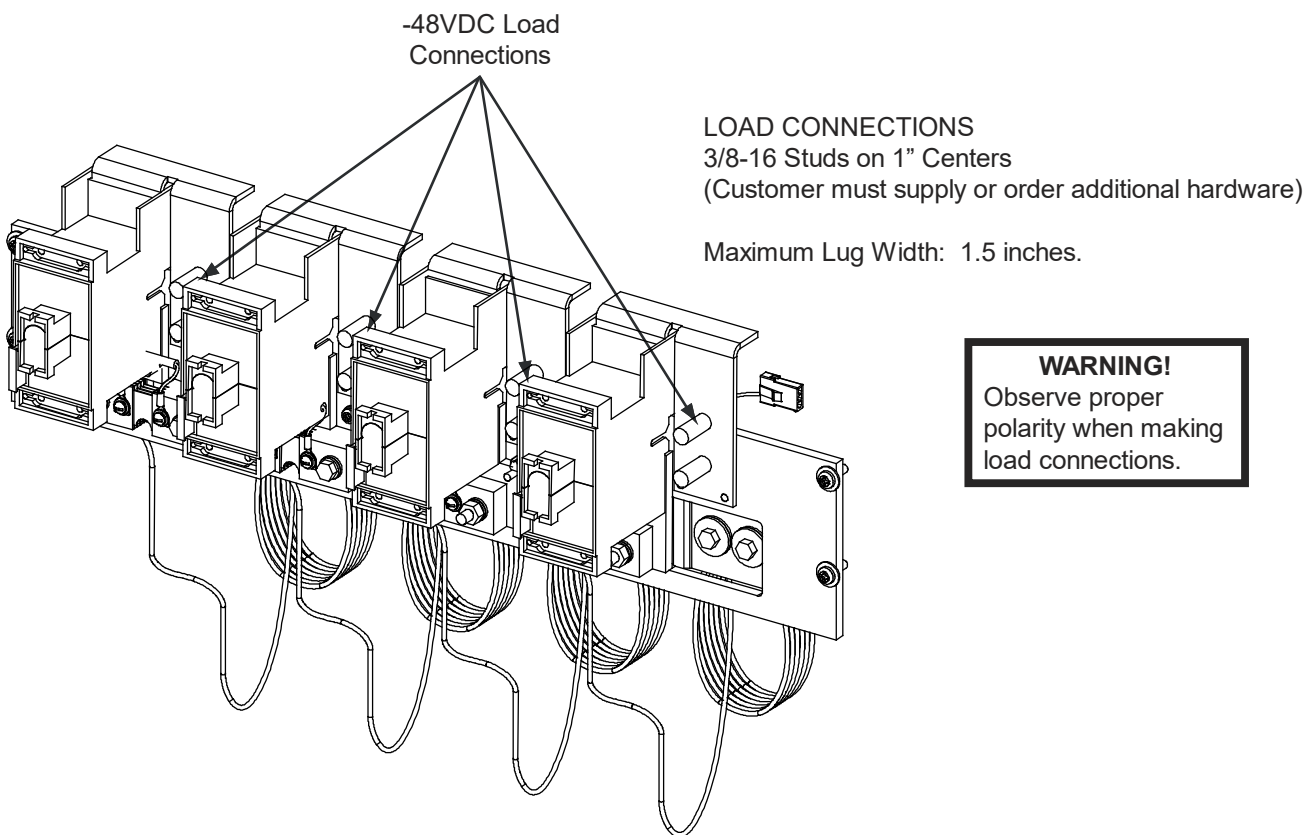


Figure 5.42 List AK: -48V Distribution Panel, (4) TPL-B Fuse Positions (with Shunts) (without Return Busbar)



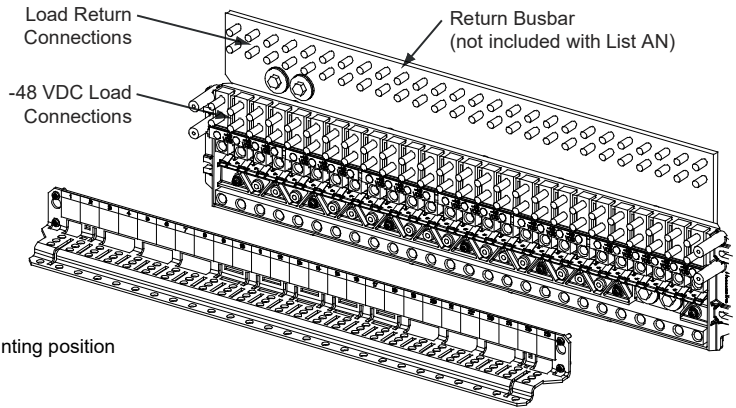
**Figure 5.43 List AL and List AN: -48 VDC Distribution Panel, (26) Bullet/TPS/TLS Circuit Breaker/Fuse Positions**

LOAD AND LOAD RETURN CONNECTIONS  
 1/4-20 Studs on 5/8" Centers  
 (Customer must supply or order additional hardware)

Maximum Lug Width: 0.625 inches.

**WARNING!**  
 Observe proper polarity when making load connections.

Caution: A 100 A circuit breakers and fuses can be used without a space provided the continuous operating current in each 100 A device does not exceed 64 A. A 175 A or greater circuit breaker shall have an empty mounting position between it and any other overcurrent protective device.



**Figure 5.44 List AM and List AP: -48 VDC Distribution Panel, (12) GJ/218 Circuit Breaker Positions**

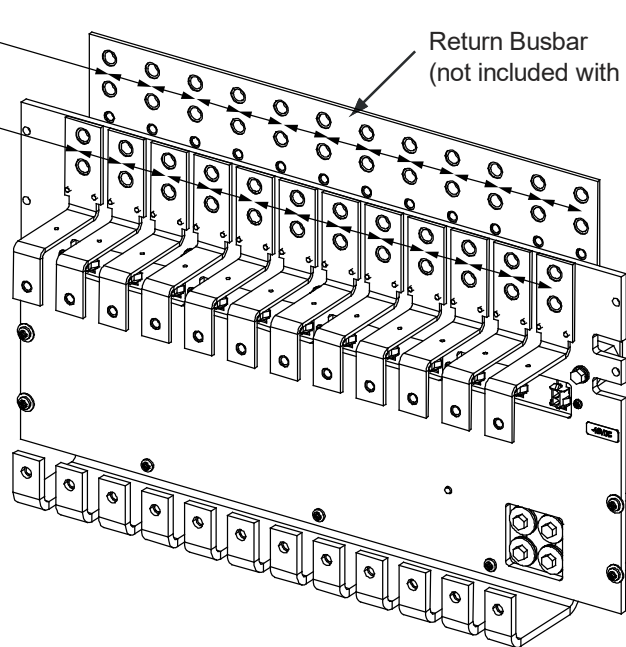
Load Return Connections  
 -48 VDC Load Connections

Return Busbar  
 (not included with List AP)

LOAD AND LOAD RETURN CONNECTIONS  
 3/8-16 Captive Nuts on 1" Centers  
 (Customer must supply or order additional hardware)

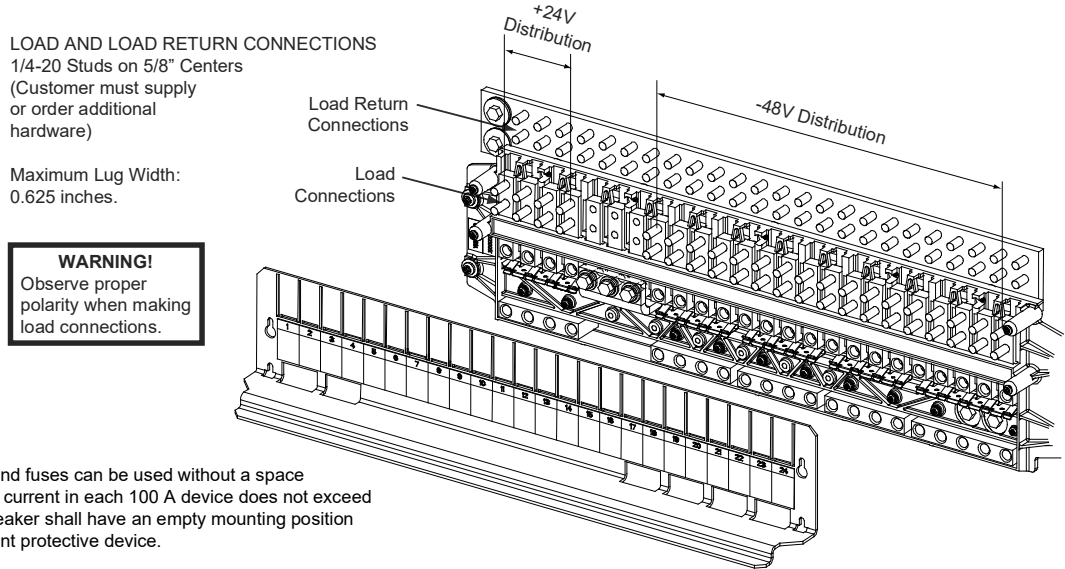
Maximum Lug Width: 1.375 inches.

**WARNING!**  
 Observe proper polarity when making load connections.



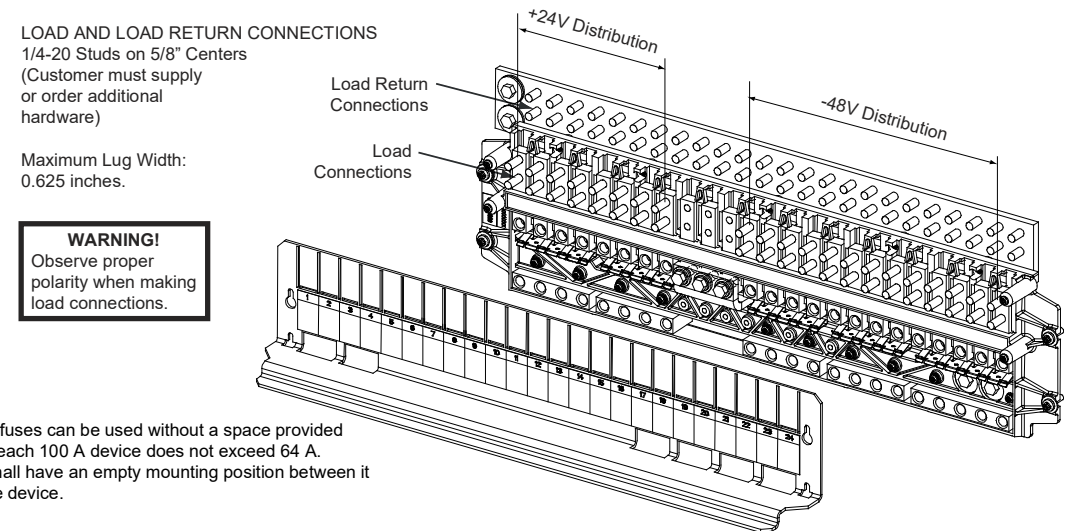
### 5.10.3 Load Connections to Dual Voltage Distribution Panels

**Figure 5.45 List DA: -48V/+24V Distribution Panel, (17) -48V Bullet/TPS/TLS Circuit Breaker/Fuse Positions (with Return Busbar) and (4) +24V Bullet/TPS/TLS Circuit Breaker/Fuse Positions (with Return Busbar)**



Caution: A 100 A circuit breakers and fuses can be used without a space provided the continuous operating current in each 100 A device does not exceed 64 A. A 175 A or greater circuit breaker shall have an empty mounting position between it and any other overcurrent protective device.

**Figure 5.46 List DB: -48V/+24V Distribution Panel, (13) -48V Bullet/TPS/TLS Circuit Breaker/Fuse Positions (with Return Busbar) and (8) +24V Bullet/TPS/TLS Circuit Breaker/Fuse Positions (with Return Busbar)**



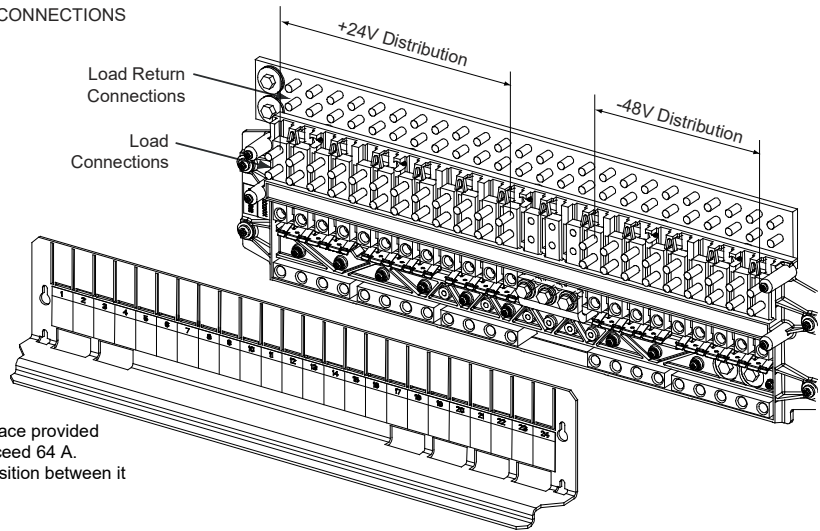
Caution: 100 A circuit breakers and fuses can be used without a space provided the continuous operating current in each 100 A device does not exceed 64 A. A 175 A or greater circuit breaker shall have an empty mounting position between it and any other overcurrent protective device.

**Figure 5.47 List DC: -48V/+24V Distribution Panel, (9) -48V Bullet/TPS/TLS Circuit Breaker/Fuse Positions (with Return Busbar) and (12) +24V Bullet/TPS/TLS Circuit Breaker/Fuse Positions (with Return Busbar)**

LOAD AND LOAD RETURN CONNECTIONS  
 1/4-20 Studs on 5/8" Centers  
 (Customer must supply or order additional hardware)

Maximum Lug Width:  
 0.625 inches.

**WARNING!**  
 Observe proper polarity when making load connections.



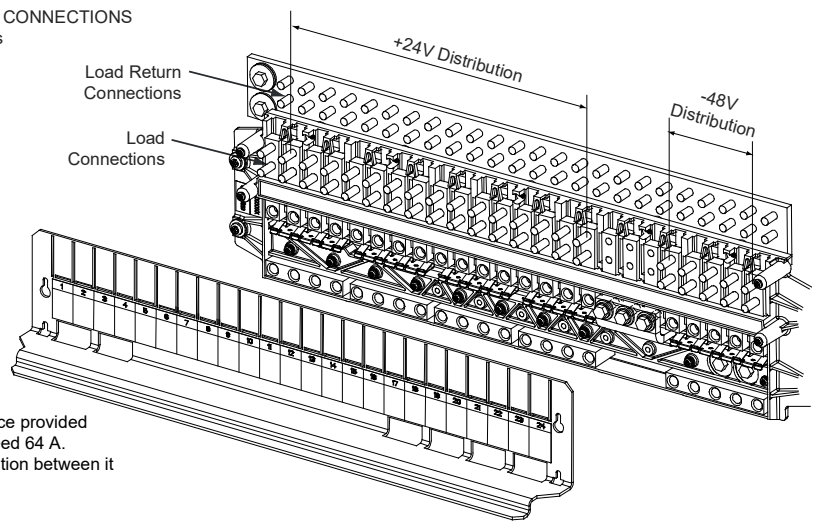
Caution: 100 A circuit breakers and fuses can be used without a space provided the continuous operating current in each 100 A device does not exceed 64 A. A 175 A or greater circuit breaker shall have an empty mounting position between it and any other overcurrent protective device.

**Figure 5.48 List DD: -48V/+24V Distribution Panel, (5) -48V Bullet/TPS/TLS Circuit Breaker/Fuse Positions (with Return Busbar) and (16) +24V Bullet/TPS/TLS Circuit Breaker/Fuse Positions (with Return Busbar)**

LOAD AND LOAD RETURN CONNECTIONS  
 1/4-20 Studs on 5/8" Centers  
 (Customer must supply or order additional hardware)

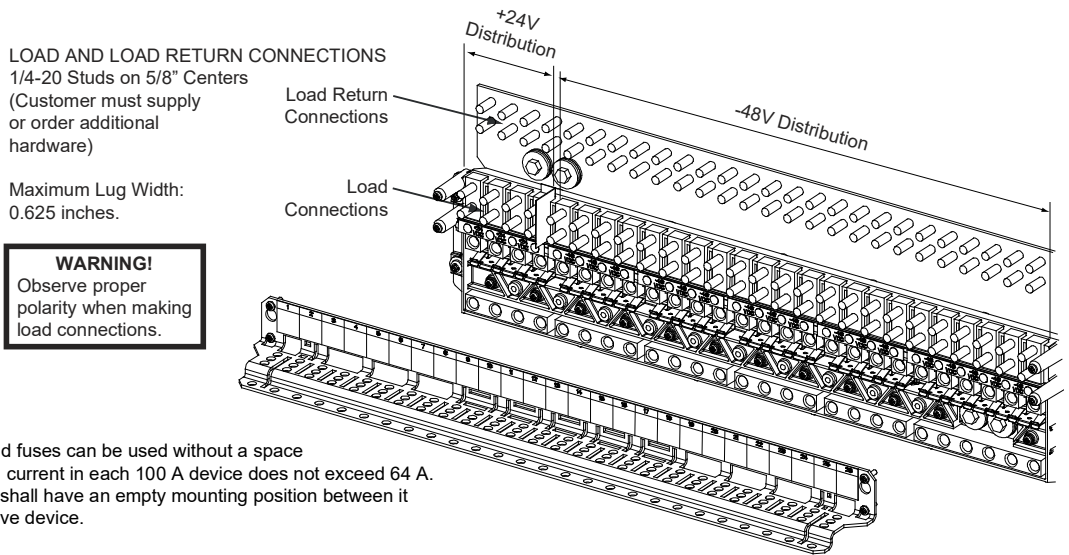
Maximum Lug Width:  
 0.625 inches.

**WARNING!**  
 Observe proper polarity when making load connections.



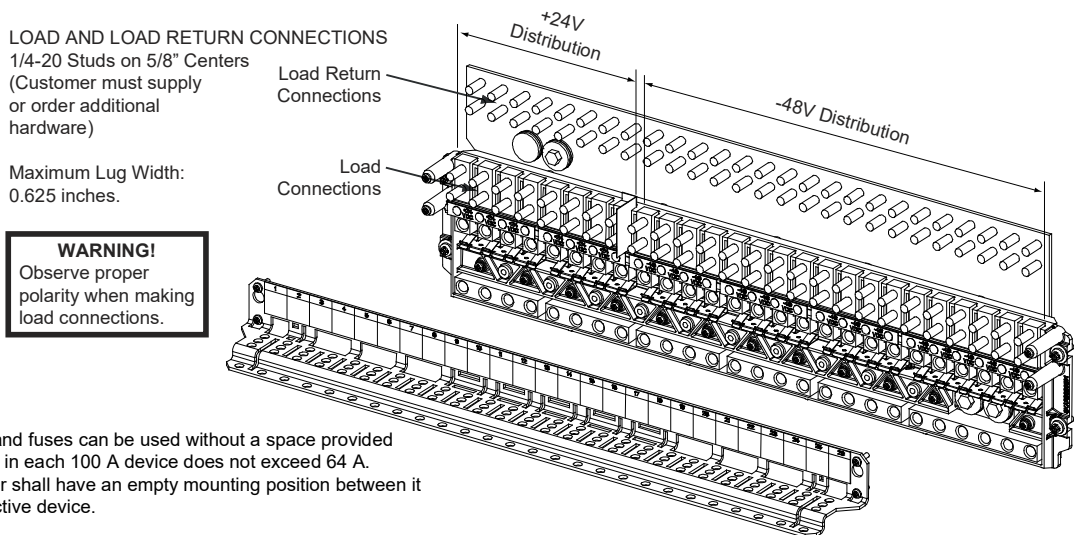
Caution: 100 A circuit breakers and fuses can be used without a space provided the continuous operating current in each 100 A device does not exceed 64 A. A 175 A or greater circuit breaker shall have an empty mounting position between it and any other overcurrent protective device.

**Figure 5.49 List DE: -48 VDC / +24 VDC Distribution Panel, (22) -48 VDC Bullet/TPS/TLS Circuit Breaker/Fuse Positions (with Return Busbar) and (4) +24 VDC Bullet/TPS/TLS Circuit Breaker/Fuse Positions (with Return Busbar)**



Caution: 100 A circuit breakers and fuses can be used without a space provided the continuous operating current in each 100 A device does not exceed 64 A. A 175 A or greater circuit breaker shall have an empty mounting position between it and any other overcurrent protective device.

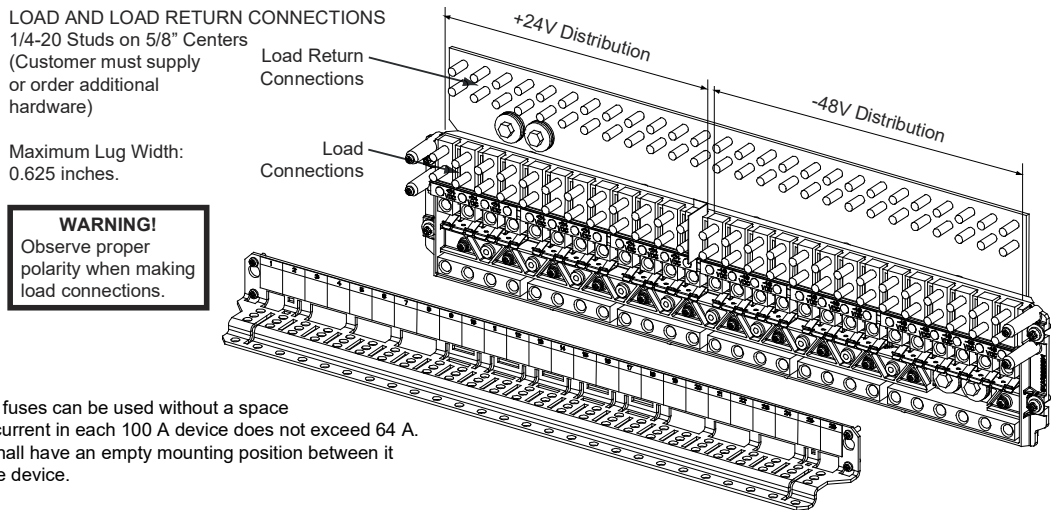
**Figure 5.50 List DF: -48 VDC / +24 VDC Distribution Panel, (18) -48 VDC Bullet/TPS/TLS Circuit Breaker/Fuse Positions (with Return Busbar) and (8) +24 VDC Bullet/TPS/TLS Circuit Breaker/Fuse Positions (with Return Busbar)**



Caution: 100 A circuit breakers and fuses can be used without a space provided the continuous operating current in each 100 A device does not exceed 64 A. A 175 A or greater circuit breaker shall have an empty mounting position between it and any other overcurrent protective device.

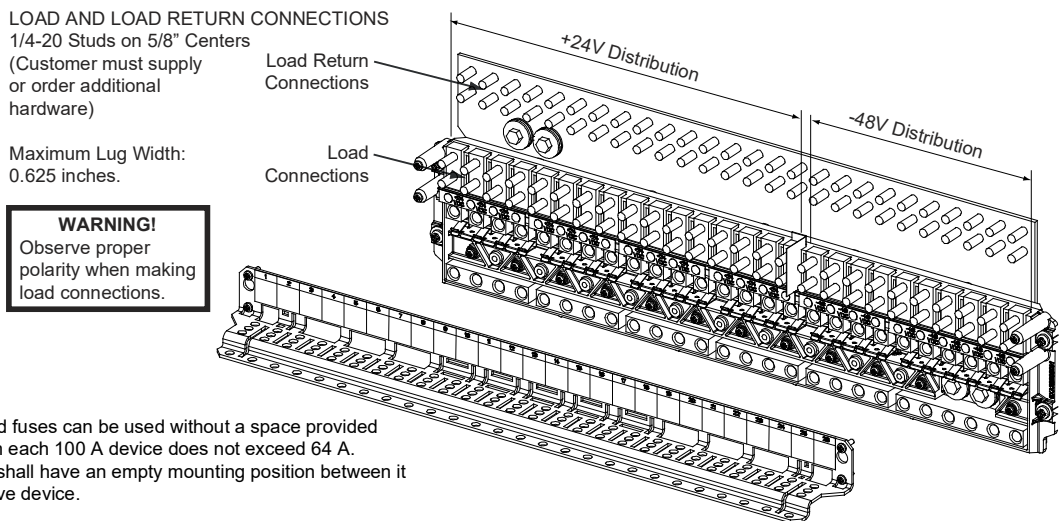


**Figure 5.51 List DG: -48 VDC / +24 VDC Distribution Panel, (14) -48 VDC Bullet/TPS/TLS Circuit Breaker/Fuse Positions (with Return Busbar) and (12) +24 VDC Bullet/TPS/TLS Circuit Breaker/Fuse Positions (with Return Busbar)**



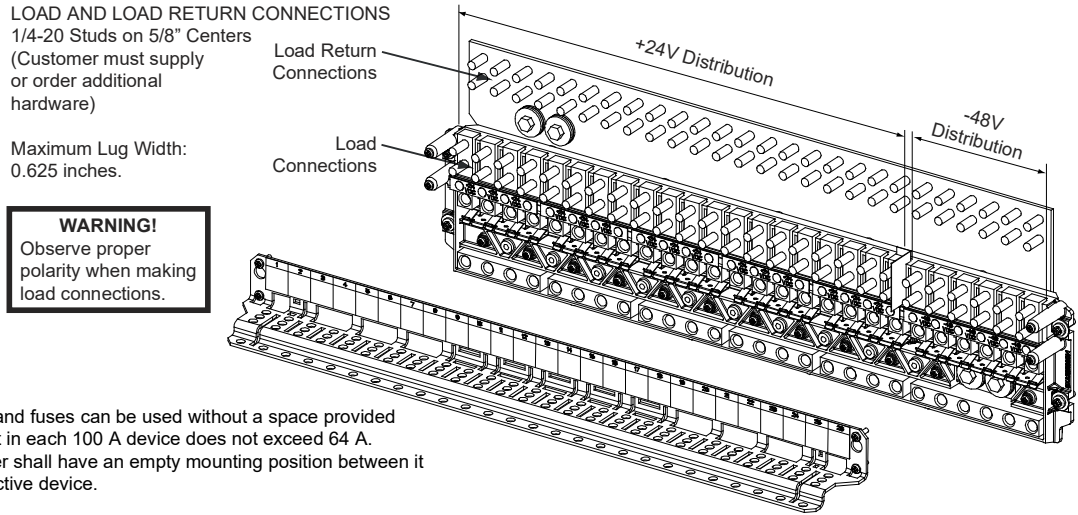
Caution: 100 A circuit breakers and fuses can be used without a space provided the continuous operating current in each 100 A device does not exceed 64 A. A 175 A or greater circuit breaker shall have an empty mounting position between it and any other overcurrent protective device.

**Figure 5.52 List DH: -48 VDC / +24 VDC Distribution Panel, (10) -48 VDC Bullet/TPS/TLS Circuit Breaker/Fuse Positions (with Return Busbar) and (16) +24 VDC Bullet/TPS/TLS Circuit Breaker/Fuse Positions (with Return Busbar)**



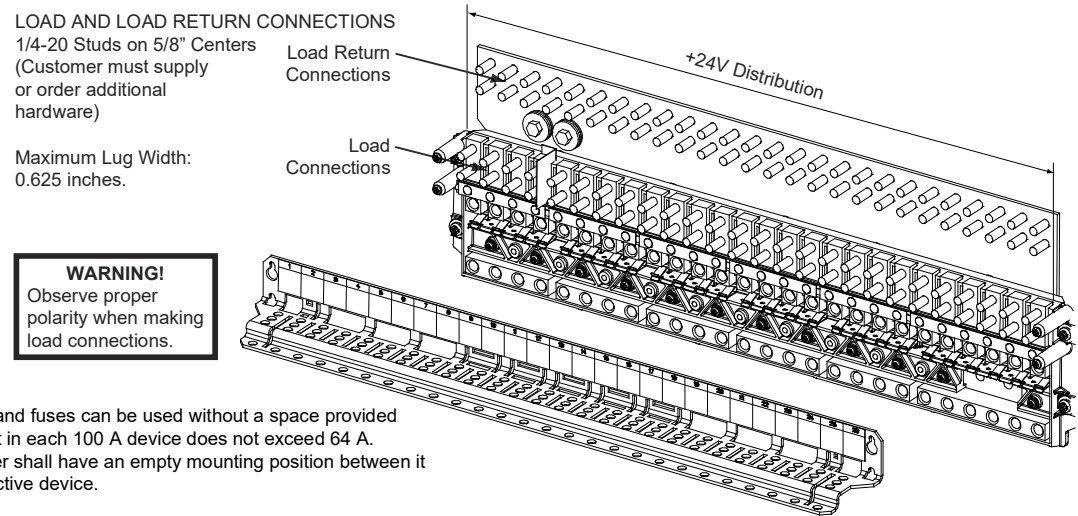
Caution: 100 A circuit breakers and fuses can be used without a space provided the continuous operating current in each 100 A device does not exceed 64 A. A 175 A or greater circuit breaker shall have an empty mounting position between it and any other overcurrent protective device.

**Figure 5.53 List DJ: -48 VDC / +24 VDC Distribution Panel, (6) -48 VDC Bullet/TPS/TLS Circuit Breaker/Fuse Positions (with Return Busbar) and (20) +24 VDC Bullet/TPS/TLS Circuit Breaker/Fuse Positions (with Return Busbar)**



Caution: 100 A circuit breakers and fuses can be used without a space provided the continuous operating current in each 100 A device does not exceed 64 A. A 175 A or greater circuit breaker shall have an empty mounting position between it and any other overcurrent protective device.

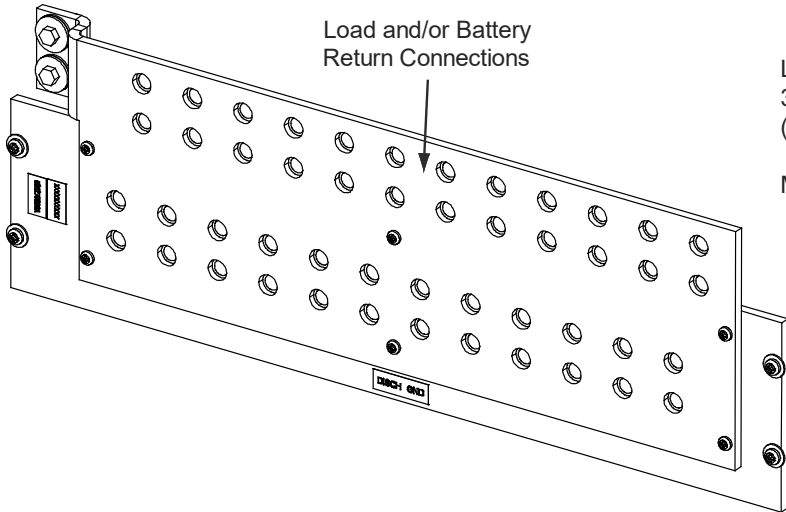
**Figure 5.54 List DK: -48 VDC / +24 VDC Distribution Panel, (26) +24 VDC Bullet/TPS/TLS Circuit Breaker/Fuse Positions (with Return Busbar)**



Caution: 100 A circuit breakers and fuses can be used without a space provided the continuous operating current in each 100 A device does not exceed 64 A. A 175 A or greater circuit breaker shall have an empty mounting position between it and any other overcurrent protective device.

### 5.10.4 Load Connections to Return Bar

Figure 5.55 List GA: Return Bar Panel



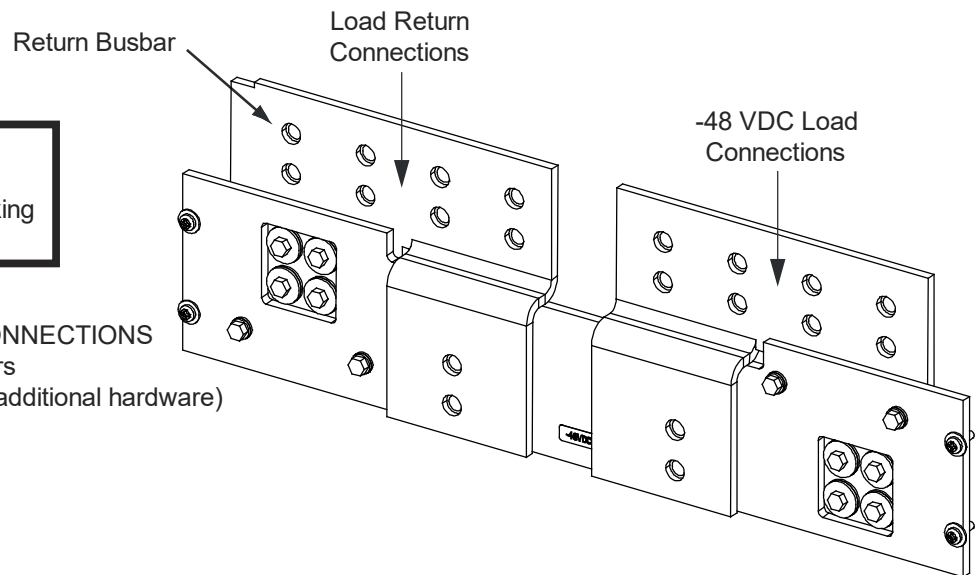
LOAD AND/OR BATTERY RETURN CONNECTIONS  
3/8-16 Captive Nuts on 1" Centers  
(Customer must supply or order additional hardware)

Maximum Lug Width: 1.38 inches.

### 5.10.5 Load Connections to Bulk Output Panel

Figure 5.56 List EA: Bulk Output Panel

**WARNING!**  
Observe proper polarity when making load connections.

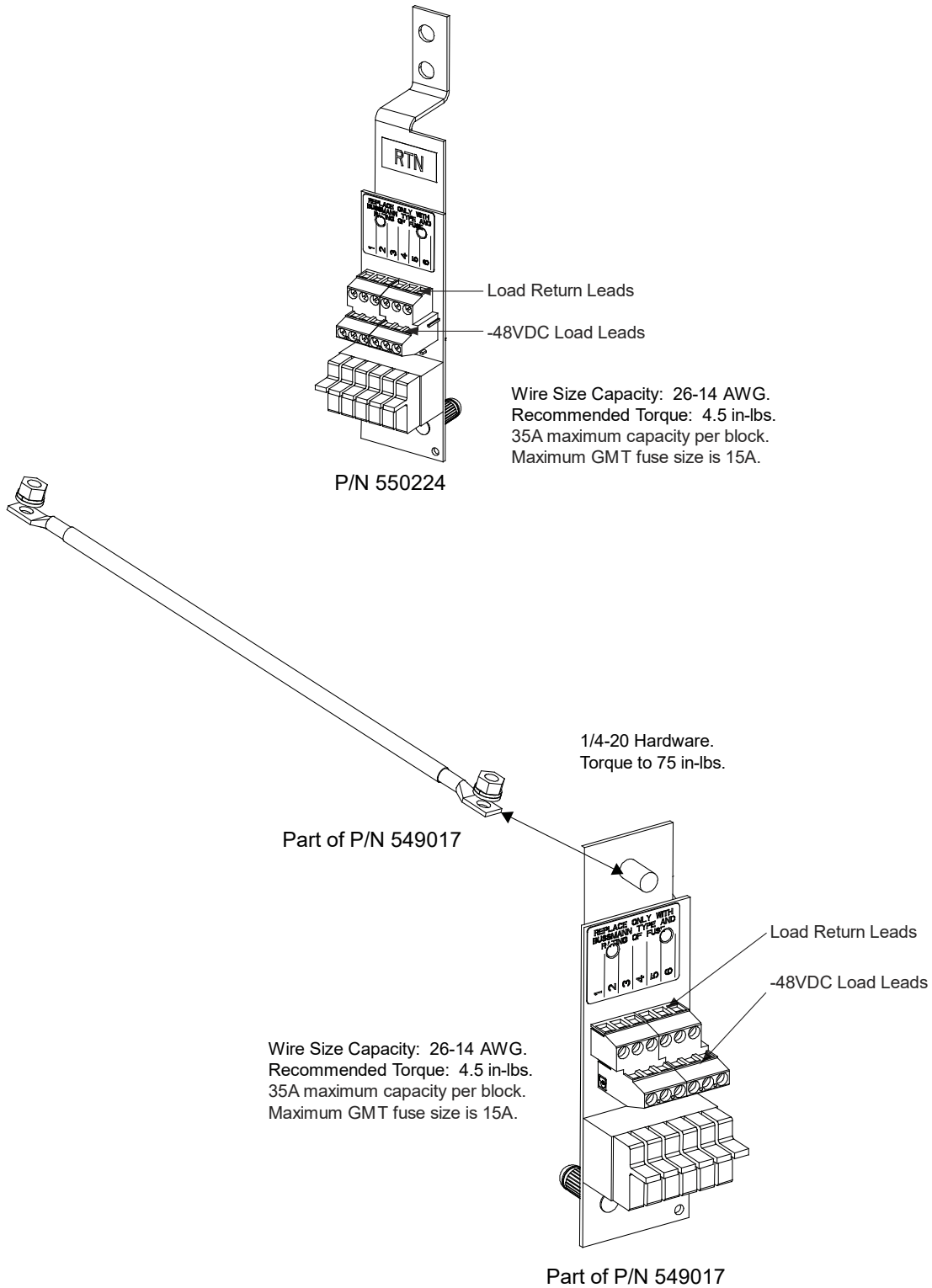


LOAD AND LOAD RETURN CONNECTIONS  
3/8-16 Captive Nuts on 1" Centers  
(Customer must supply or order additional hardware)

Maximum Lug Width: 2.0 inches.

### 5.10.6 Load Connections to GMT Distribution Fuse Block

Figure 5.57 Optional Bullet Nose 6-Position GMT Distribution Fuse Block



## 5.11 Make Battery Connections

Refer to *Battery Connections* in the MAKING ELECTRICAL CONNECTIONS section of the Installation Instructions (IM582127000) for complete procedures.

### 5.11.1 Recommended Torques

- 72 in-lbs for 1/4-inch hardware (when using standard flat and lock washer).
- 300 in-lbs for 3/8-inch hardware (when using standard flat and lock washer).
- 180 in-lbs for 3/8-inch hardware (when using a Belleville lock washer).

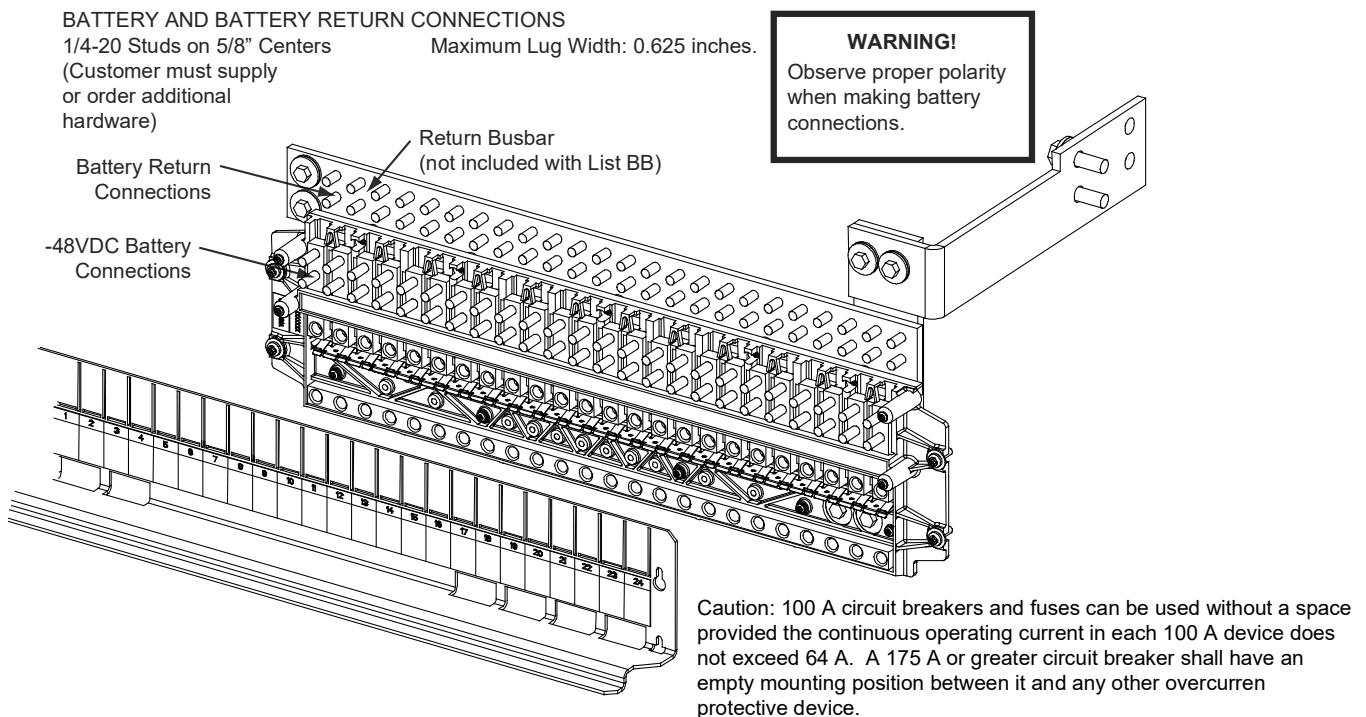
### 5.11.2 Battery Connections to Optional Battery Disconnect Distribution Panels



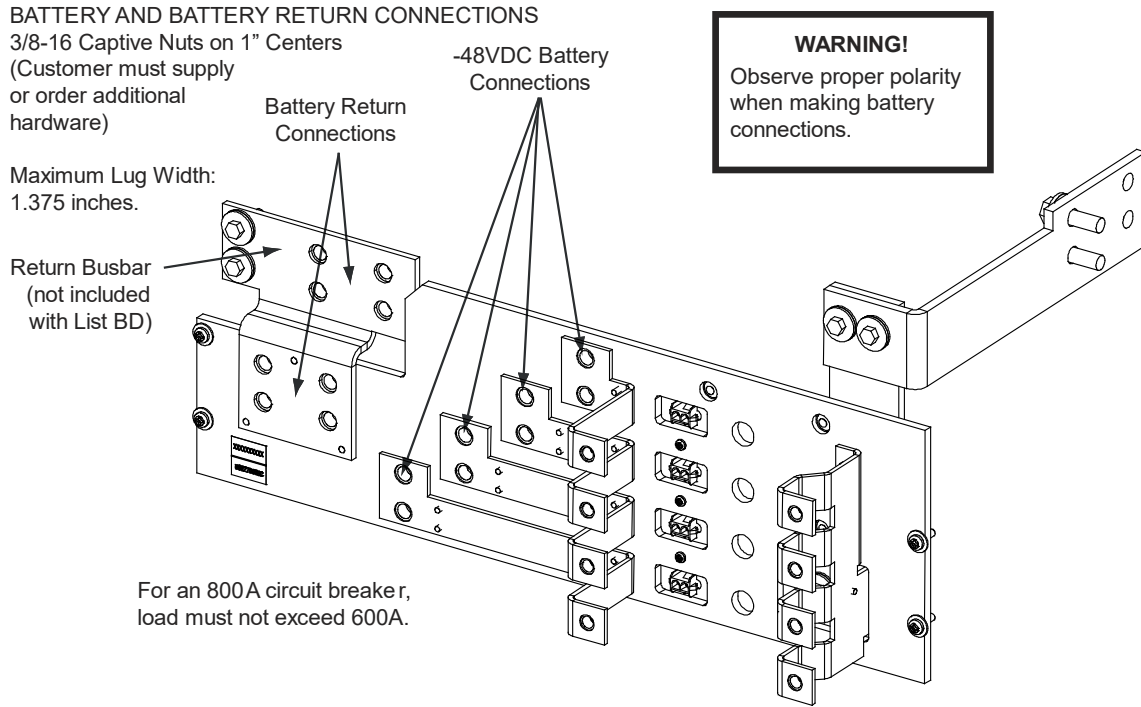
**DANGER!** Adhere to the “Important Safety Instructions” presented at the front of this document.

Battery strings are connected to the various battery disconnect distribution panels (if furnished) located inside the distribution cabinet, as detailed in the illustrations in this section.

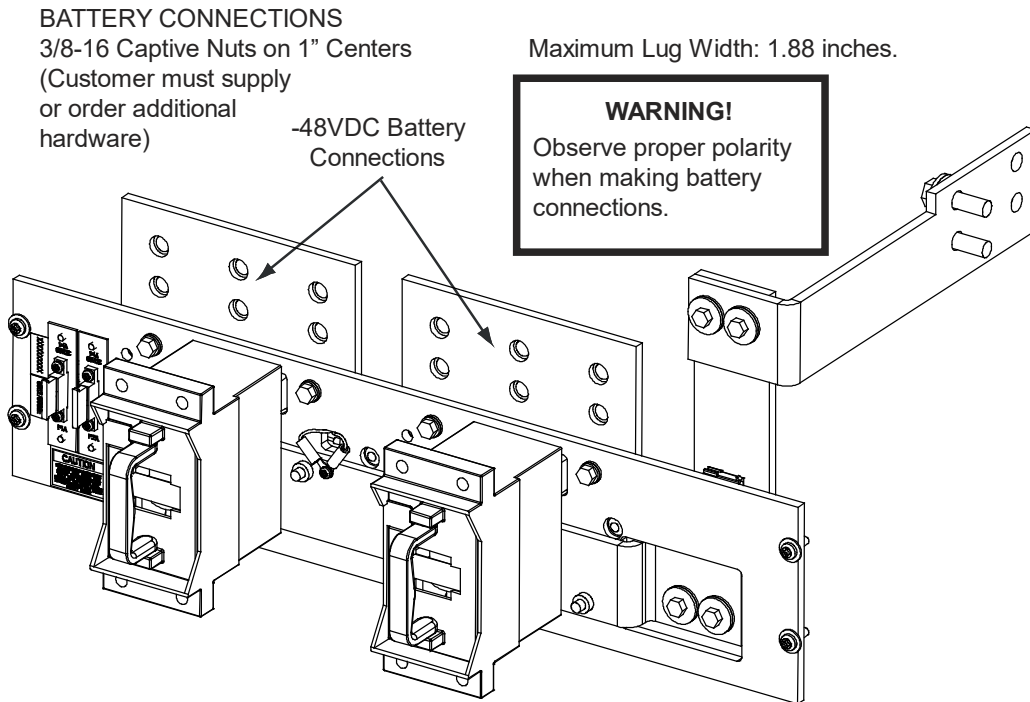
**Figure 5.58** List BA: Battery Disconnect Distribution Panel (with Return Busbar) and List BB: Battery Disconnect Distribution Panel (without Return Busbar), (24) Bullet/TPS/TLS Circuit Breaker/Fuse Battery Disconnect Positions



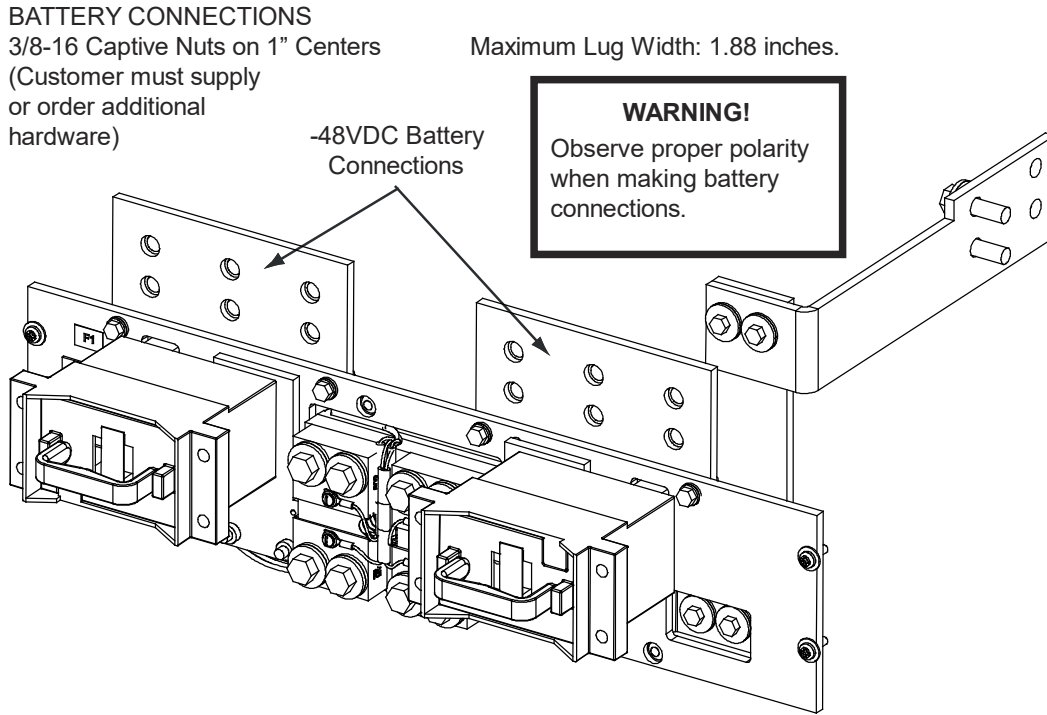
**Figure 5.59** List BC: Battery Disconnect Distribution Panel (with Return Busbar) and List BD: Battery Disconnect Distribution Panel (without Return Busbar), (4) GJ/218 Circuit Breaker Battery Disconnect Positions



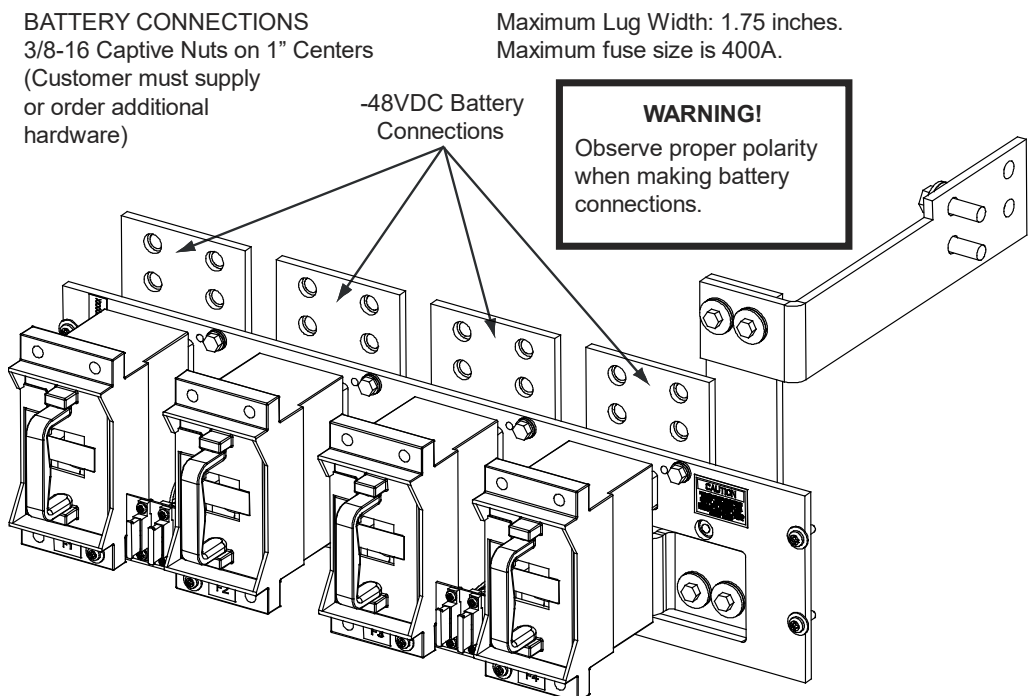
**Figure 5.60** List BE: Battery Disconnect Distribution Panel, (2) TPH Fuse Battery Disconnect Position (without Shunts) (without Return Busbar)



**Figure 5.61 List BF: Battery Disconnect Distribution Panel, (2) TPH Fuse Battery Disconnect Positions (with Shunts) (without Return Busbar)**



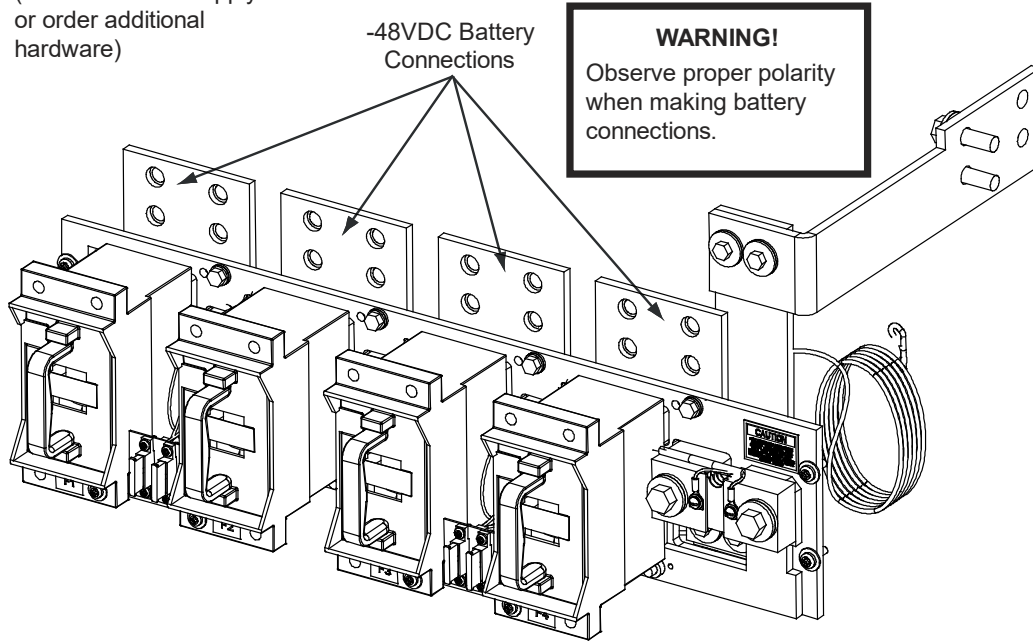
**Figure 5.62 List BG: Battery Disconnect Distribution Panel, (4) TPH Fuse Battery Disconnect Positions (without Shunts) (without Return Busbar)**



**Figure 5.63 List BH: Battery Disconnect Distribution Panel, (4) TPH Fuse Battery Disconnect Positions (with Shunts) (without Return Busbar)**

**BATTERY CONNECTIONS**  
3/8-16 Captive Nuts on 1" Centers  
(Customer must supply  
or order additional  
hardware)

Maximum Lug Width: 1.75 inches.  
Maximum fuse size is 400A.





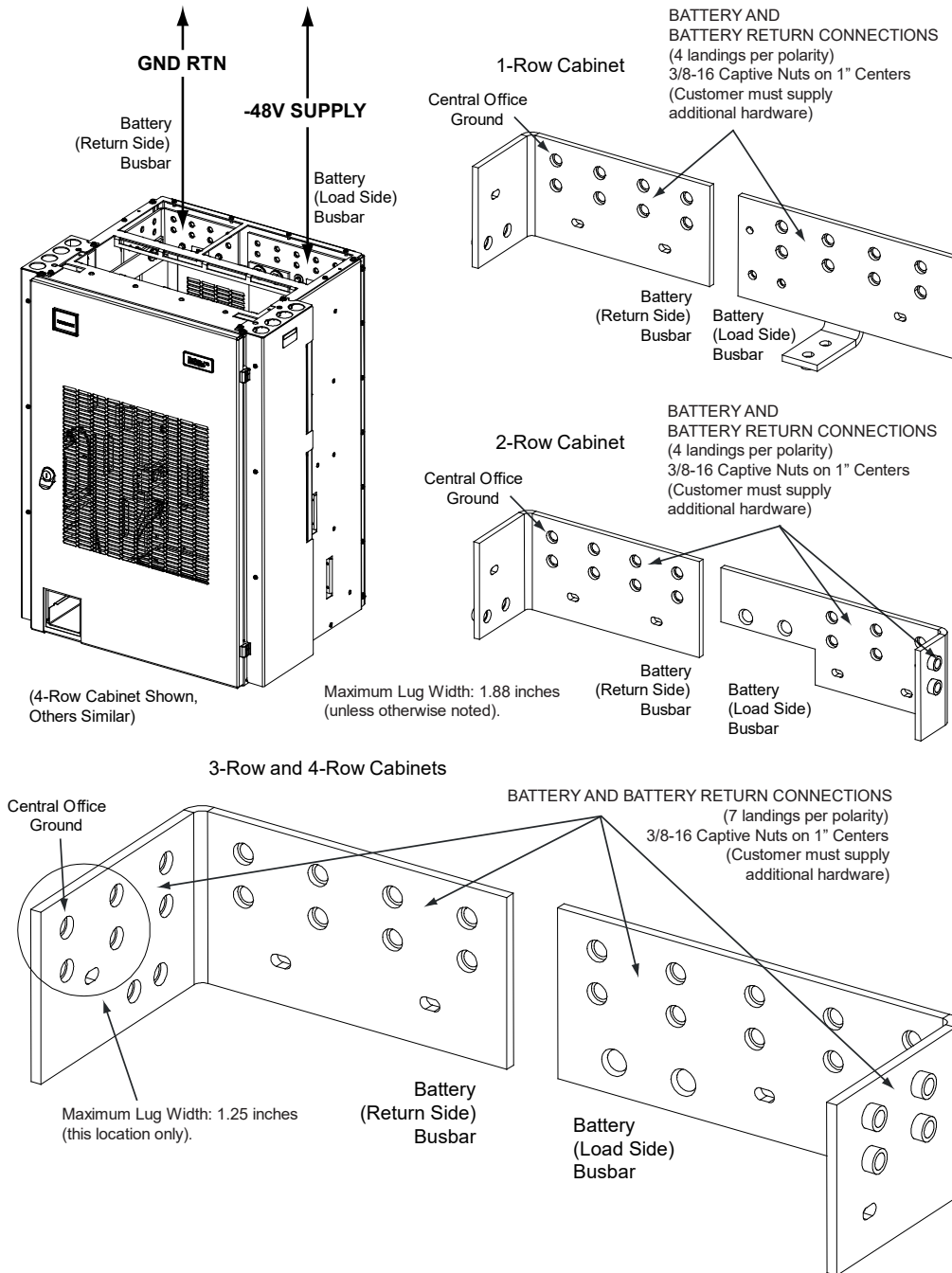
### 5.11.3 Battery Connections to Distribution Cabinet Battery Busbars (for system mounted in a relay rack or enclosure)



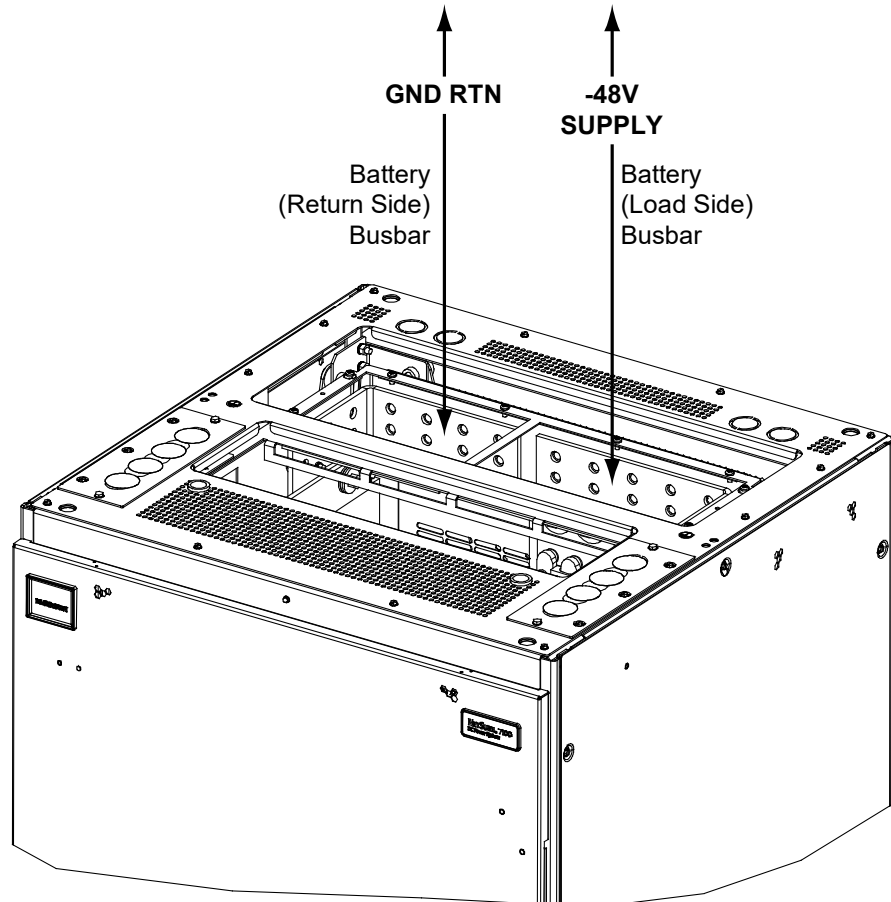
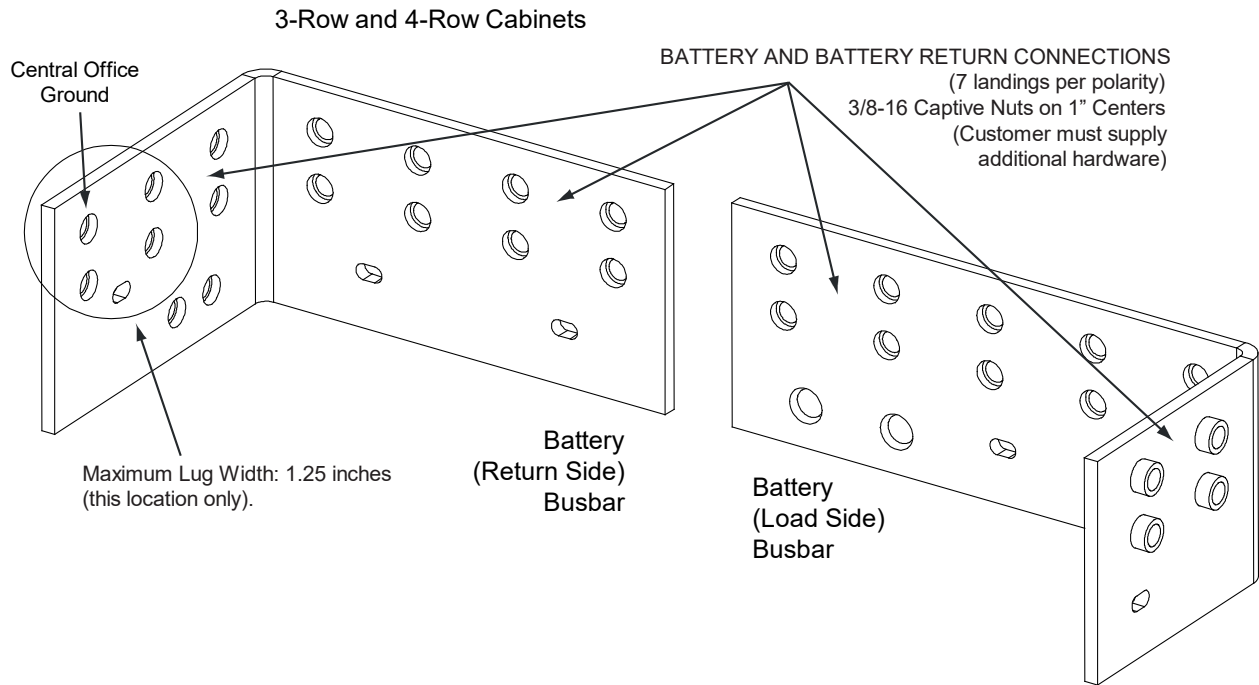
**DANGER!** Adhere to the “Important Safety Instructions” presented at the front of this document.

Battery may be connected to the battery busbars located in the distribution cabinet, as detailed in **Figure 72** and **Figure 73**, depending on site requirements.

**Figure 5.64** Battery Connections to Distribution Cabinet Battery Busbars (for system mounted in a relay rack)



**Figure 5.65 Battery Connections to Distribution Cabinet Battery Busbars (for system mounted in an enclosure)**



**Power System Installed in a Cabinet (Front View)**

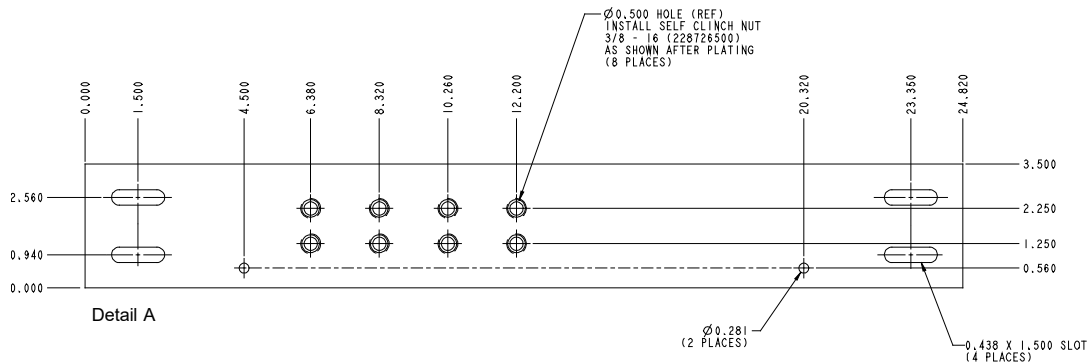
### 5.11.4 Battery Connections to Bay-to-Bay Rectifier Busbars (582127000 List 1 with List 2 / List 3) (for system mounted in a relay rack)



**DANGER!** Adhere to the “Important Safety Instructions” presented at the front of this document.

IF THE SYSTEM DOES NOT CONTAIN A BATTERY SHUNT OR BATTERY DISCONNECT CONTACTOR, battery may be connected to the 582127000 List 2 and List 3 bay-to-bay rectifier busbars located on the rear of the distribution cabinets, as detailed in **Figure 74**, depending on site requirements.

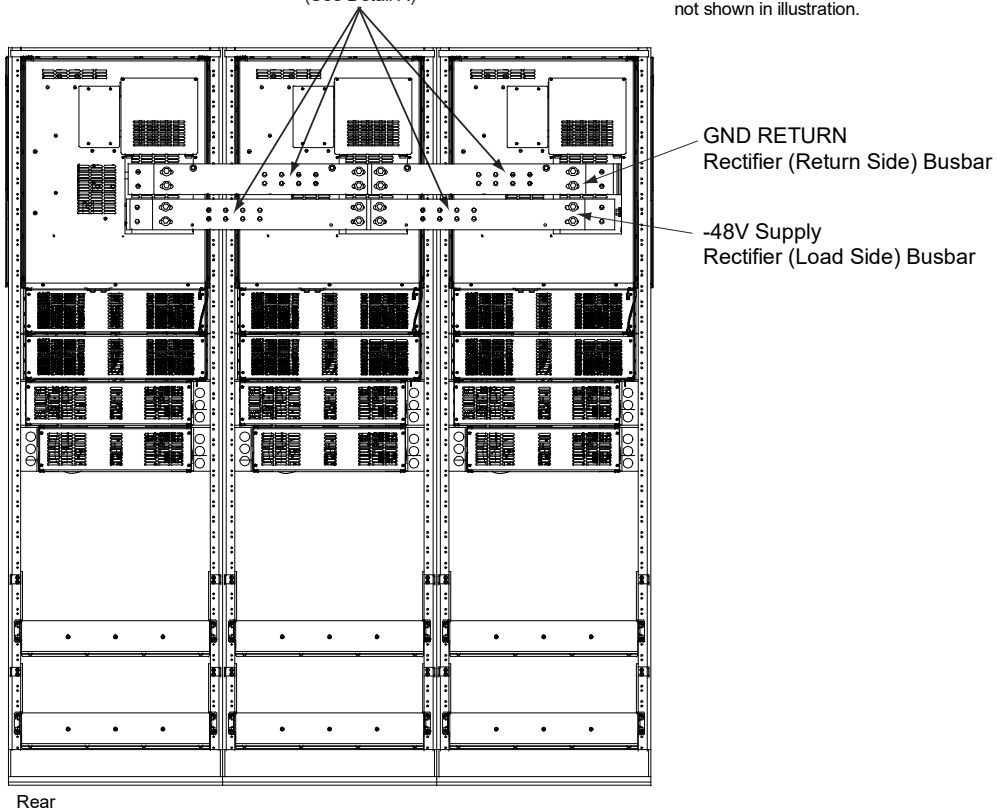
**Figure 5.66** Battery Connections to Bay-to-Bay Rectifier Busbars (for system mounted in a relay rack)



RECTIFIER AND RECTIFIER RETURN CONNECTIONS  
(CAN ONLY BE USED FOR BATTERY CONNECTIONS  
IF THE SYSTEM DOES NOT CONTAIN A BATTERY  
SHUNT OR BATTERY DISCONNECT CONTACTOR)  
3/8-16 Captive Nuts on 1" Centers  
(Customer must supply additional hardware.)  
Maximum Lug Width: 1.88 inches.  
(See Detail A)

Notes:  
1. All dimensions are in inches.

Rear busbar cover shields  
not shown in illustration.



## 5.12 List 93 Battery Tray

Refer to *Installing and Connecting Batteries in a List 93 Battery Tray (if furnished)* in the MAKING ELECTRICAL CONNECTIONS section of the Installation Instructions (IM582127000) for a complete procedure.

# 6 Installing the Modules

## 6.1 Installing Rectifier or Converter Modules into Spec. No. 588705000 Module Mounting Assemblies

Rectifier or converter modules are installed in a 588705000 module mounting assembly, depending on the shelf ordered.

- Rectifiers are installed in 588705000 List 21, List 22, 31, and 32 shelves.
- Converters are installed in 588705000 List 40, List 41, and 42 shelves.

Rectifier or converter modules can be inserted or removed with power applied (hot swappable).



**NOTE!** *The rectifier or converter module locks into the module mounting assembly through a latch located on the underside of the module. The latch and module handle are interactive. Push the handle into the module's front panel, and the latch will pop out from the module bottom. Click the handle to pop it out from the module's front panel, and the latch will retract back into the module. The latch mechanism is shown in **Figure 75**.*



**WARNING!** To prevent damage to the latching mechanism, ensure the handle is in the open position when installing or removing a module. NEVER hold the handle in the closed position when installing a module into a shelf.

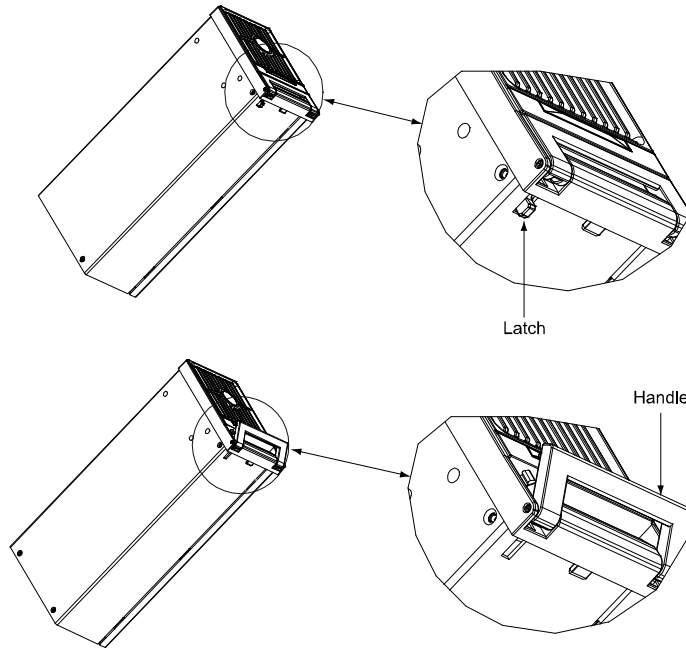


**NOTE!** *588705000 List 32 and List 33 Rectifier Mounting Assemblies Only (3-Phase Input): One three-phase input feeds the three rectifier modules on the left-hand side of the shelf. The second three-phase input feeds the modules on the right-hand side. To maintain phase balance, install rectifier modules in groups of three; that is, fill all three mounting positions on the left and/or all three on the right.*

### **Procedure**

1. Unpack the rectifier or converter modules.
2. If present, remove blank cover panels from the module mounting positions into which modules are to be installed.
3. Place the module into an unoccupied mounting slot without sliding it in completely.
4. Click the module handle in order to pop it forwards out of the module's front panel (this will also retract the latch mechanism located on the underside of the module).
5. Push the module completely into the shelf.
6. Push the handle into the front panel of the module. This will make the latch lock the module securely to the shelf.
7. Repeat the above steps for each module being installed in the system.
8. After the modules are physically installed in the mounting shelf(s), they are ready for operation immediately after power is supplied to them.

**Figure 6.1** Installing Rectifier or Converter Modules into Spec. No. 588705000 Module Mounting Assembly



## 6.2 Installing Rectifier Modules into Spec. No. 588705500 Module Mounting Assemblies

Rectifier modules can be inserted or removed with power applied (hot swappable).



**NOTE!** The rectifier module locks into the module mounting assembly through a latch located on the underside of the module. The latch and module handle are interactive. Push the handle into the module's front panel, and the latch will pop out from the module bottom. Click the handle to pop it out from the module's front panel, and the latch will retract back into the module. The latch mechanism is shown in **Figure 76**.



**WARNING!** To prevent damage to the latching mechanism, ensure the handle is in the open position when installing or removing a module. NEVER hold the handle in the closed position when installing a module into a shelf.

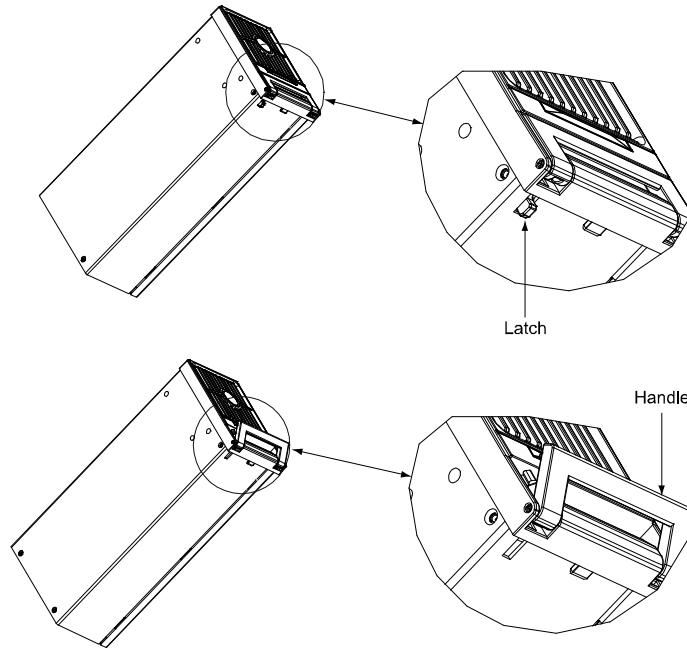


**NOTE!** *588705500 List 04 and List 05 Rectifier Mounting Assemblies Only (3-Phase Input):* One three-phase input feeds the three rectifier modules on the left-hand side of the shelf. The second three-phase input feeds the modules on the right-hand side. To maintain phase balance, install rectifier modules in groups of three; that is, fill all three mounting positions on the left and/or all three on the right.

### **Procedure**

1. Unpack the rectifier modules.
2. If present, remove blank cover panels from the module mounting positions into which modules are to be installed.
3. Place the module into an unoccupied mounting slot without sliding it in completely.
4. Click the module handle in order to pop it forwards out of the module's front panel (this will also retract the latch mechanism located on the underside of the module).
5. Push the module completely into the shelf.
6. Push the handle into the front panel of the module. This will make the latch lock the module securely to the shelf.
7. Repeat the above steps for each module being installed in the system.
8. After the modules are physically installed in the mounting shelf(s), they are ready for operation immediately after power is supplied to them.

**Figure 6.2** Installing Rectifier Modules into Spec. No. 588705500 Module Mounting Assembly



## 6.3 Installing the Rectifier and Converter Modules into Spec. No. 588705300 Module Mounting Assemblies

Rectifier and converter modules can be inserted or removed with power applied (hot swappable).

Rectifiers modules can be installed in any mounting position of each module mounting assembly. Converters modules can be installed in any of the three far right mounting positions of each module mounting assembly (as viewed from the front). See **Figure 77**.



**NOTE!** Each rectifier and converter module locks into the module mounting assembly by means of a latch located on the bottom of the module. The latch and module handle are interactive. Pushing the handle up into the module's front panel causes the latch to extend to the locking position; pulling the handle down out from the module's front panel causes the latch to retract. See **Figure 77**.



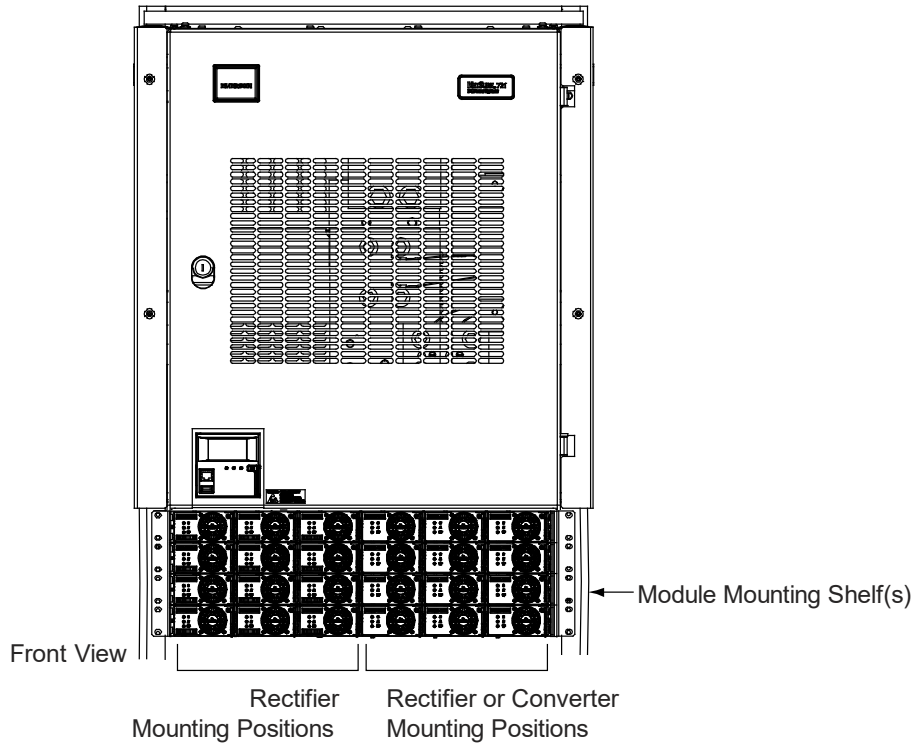
**WARNING!** To prevent damage to the latching mechanism, ensure the handle is in the open position when installing or removing a module. NEVER hold the handle in the closed position when installing a module into a shelf.

### **Procedure**

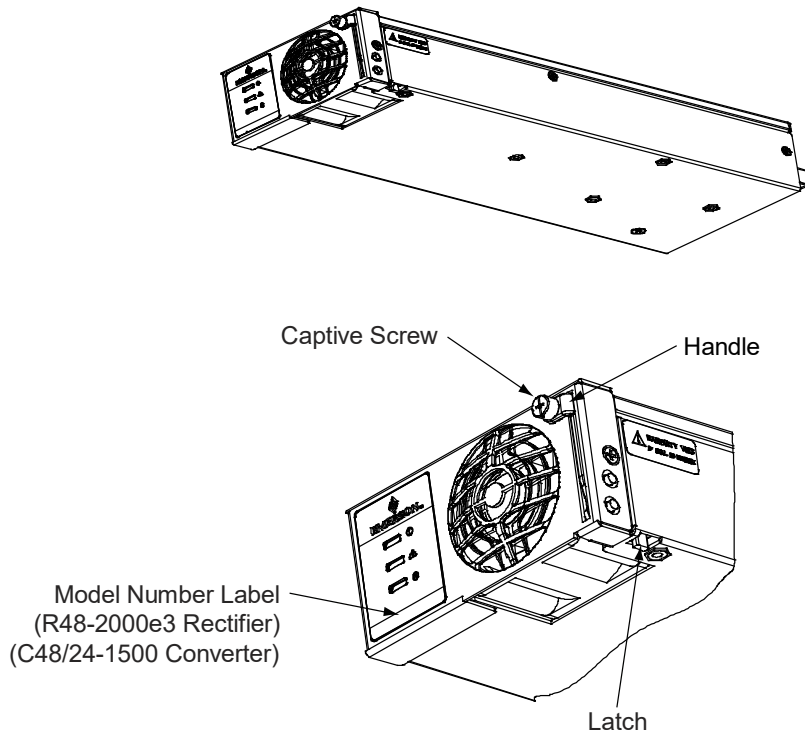
1. Unpack the modules.
2. Note the model number located on the front of each module. Model numbers starting with the letter "R" are rectifier modules. Model numbers starting with the letter "C" are converter modules.
3. Place the module into an unoccupied mounting position without sliding it in completely. Rectifiers modules can be installed in any mounting position of each module mounting assembly. Converters modules can be installed in any of the three far right mounting positions of each module mounting assembly (as viewed from the front). See **Figure 77**.
4. Loosen the captive screw on the module's handle. Pull the handle down out from the module's front panel (this will also retract the latch mechanism). See **Figure 77**.
5. Push the module completely into the shelf.
6. Push the handle up into the module's front panel. This will lock the module securely to the shelf. Tighten the captive screw on the handle.
7. Repeat the above steps for each module being installed in the system.
8. After the modules are physically installed in the mounting shelf(s), they are ready for operation immediately after power is supplied to them.



Figure 6.3 Installing Rectifier and Converter Modules into Spec. No. 588705300 Module Mounting Assembly



Rectifier or Converter Module



## 6.4 Installing Rectifier Modules into Spec. No. 588705400 Module Mounting Assemblies

Rectifiers can be inserted or removed with power applied (hot swappable).



**NOTE!** Each rectifier locks into the module mounting assembly by means of a latch located on the bottom of the rectifier. The latch and rectifier handle are interactive. Pushing the handle up into the rectifier's front panel causes the latch to extend to the locking position; pulling the handle down out from the rectifier's front panel causes the latch to retract. See **Figure 78**.



**WARNING!** To prevent damage to the latching mechanism, ensure the handle is in the open position when installing or removing a rectifier. NEVER hold the handle in the closed position when installing a rectifier into a shelf.

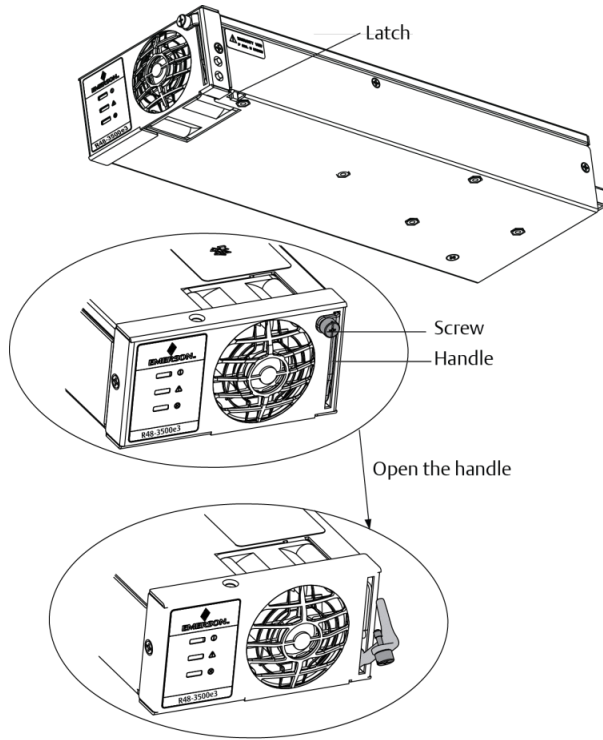


**NOTE!** *588705400 List 03 and List 04 Rectifier Mounting Assemblies Only (3-Phase Input):* One three-phase input feeds the three rectifier modules on the left-hand side of the shelf. The second three-phase input feeds the modules on the right-hand side. To maintain phase balance, install rectifier modules in groups of three; that is, fill all three mounting positions on the left and/or all three on the right.

### **Procedure**

1. Unpack the rectifiers.
2. If present, remove blank cover panels from the module mounting positions into which rectifiers are to be installed.
3. Place the rectifier into an unoccupied mounting position without sliding it in completely.
4. Loosen the captive screw on the rectifier's handle. Pull the handle down out from the rectifier's front panel (this will also retract the latch mechanism). See **Figure 78**.
5. Push the rectifier completely into the shelf.
6. Push the handle up into the rectifier's front panel. This will lock the rectifier securely to the shelf. Tighten the captive screw on the handle.
7. Repeat the above steps for each rectifier being installed in the system.
8. After the rectifiers are physically installed in the mounting assembly(s), they are ready for operation immediately after power is supplied to them.

**Figure 6.4** Installing Rectifiers into Spec. No. 588705400 Module Mounting Assembly



## 7 Initially Starting, Configuring, and Checking System Operation



**CAUTION!** Performing various steps in the following procedures may cause a service interruption and/or result in the extension of alarms. Notify any appropriate personnel before starting these procedures. Also, notify personnel when these procedures are completed.

### 7.1 Initial Startup Preparation

- Ensure that all blocks, except the last one, in the “Physical Installation” starting on page 2 have been checked.
- Ensure that module mounting positions are filled by a rectifier module, converter module, or a blank cover panel, as required. It is acceptable for positions to be left vacant.
- Refer to the configuration drawing (C-drawing) supplied with your power system documentation for factory settings of adjustable parameters.

### 7.2 Initially Starting the System

#### **Procedure**

1. Apply battery power to the system by closing the external battery disconnect(s) or protective device(s) that supplies battery power to the system, if furnished. Close the system’s internal battery disconnect circuit breakers, if furnished.
2. Apply AC or DC input power to the system (depending on configuration ordered) by closing ALL external AC or DC disconnects or protective devices that supply AC or DC input power to the module mounting assemblies. Rectifiers and/or converters automatically start.
3. Open the distribution cabinet’s front door by turning the latch in the counterclockwise position (system’s in a relay rack), or open the system’s enclosure door.
4. Place each distribution circuit breaker (if furnished) to the ON position.

### 7.3 ACU+ Controller Procedure

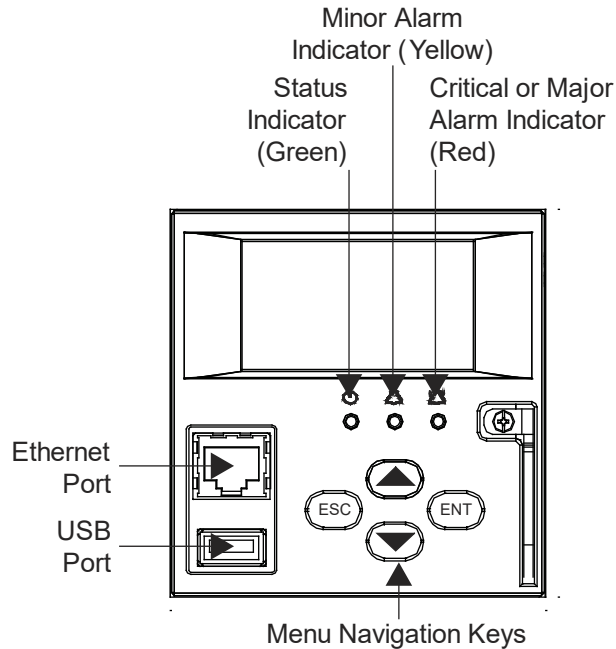
Refer to this section if your system is furnished with an ACU+ Controller.

#### **ACU+ Controller Initialization**

Refer to the ACU+ Instructions (UM1M820BNA or UM1M820DNA400) for detailed instructions.

Refer to **Figure 79** for locations of the ACU+ local indicators and navigation keys.

Figure 7.1 ACU+ Local Indicators and Navigation Keys

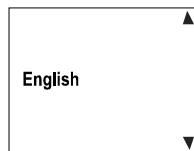


### Procedure

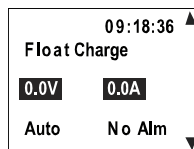


**NOTE!** The initialization routine takes several minutes. During that time various alarm indicators may illuminate on the ACU+ front panel and an audible alarm may sound. Disregard all alarms. An audible alarm can be silenced at any time by momentarily depressing the **ENT** key on the ACU+ Controller.

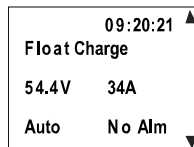
1. After the ACU+ is powered on, the display alternates between the “**logo**” screen and a screen displaying “**Advanced Control Unit Plus Version \*\*\*\*\* Starting...**”
2. Next, the language screen appears. Press the up or down arrow key to select the desired language. Press the **ENT** key to confirm the selection. If no key is pressed within 10 seconds, the ACU+ selects the displayed language automatically.



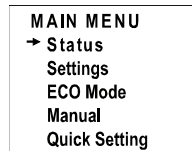
3. As initialization continues, the Main screen is displayed, but with zero volts. Initialization is not complete.



4. When initialization is complete, the Main screen displays voltage and current normally, and no alarms are active.



5. System information is displayed in multiple screens. Repetitively press the up or down arrow key to view other system information screens one by one.
6. From the Main screen, press **ENT** to go to the “Main Menu” screen.



7. From the Main Menu, select a submenu by repetitively pressing the up or down arrow key. The selected submenu will be indicated by the cursor. Press **ENT** to open the submenu.



**NOTE!** Repeatedly press the “ESC” key to return in reverse order level by level from any submenu until the Main screen appears.

8. Verify and set the ACU+ controller as required for your application. Refer to the ACU+ Instructions (UM1M820BNA or UM1M820DNA400) for procedures. Note that you will have to program the ACU+ for any temperature probes and external inputs/outputs connected to the IB2 Interface Board, optional EIB Interface Board, and optional SM-DU+ Shunt Interface Board.



**NOTE!** When setting total rectifier or total converter current limit, the set point to each unit is the total set point divided by the number of units. For example, if the system contains five rectifiers and the current limit is set to 150 amps then each rectifier has a current limit set point of 30 amps. If one or more rectifiers or converters are removed or fail it will take several seconds for the individual set points to the remaining rectifiers or converters to be reset. In the example given, if one rectifier is removed the current limit set point will drop to 120 amps (30 amps times four remaining rectifiers) until the controller can send updated set points to the remaining rectifiers. This takes a couple communication cycles (several seconds) after which each rectifier would have a new set point of 37.5 amps for a total of 150 amps. The total current limit of the rectifiers and converters should not be set such that the loss of the redundant rectifiers or converters will cause this temporary set point to drop below the actual maximum expected load. If batteries are used on the rectifier output, the batteries should support the load until the current limit set points can be re-established due to loss of a rectifier.

## **Verifying the Configuration File**

Your ACU+ was programmed with a configuration file that sets all adjustable parameters. The version number of the configuration file can be found on the configuration drawing (C-drawing) that is supplied with your power system documentation, and on a label located on the ACU+. You can verify that the correct configuration file has been loaded into your ACU+ by performing the following procedure.



**NOTE!** The quantity of LVD's and shunt values for your specific system may be different from the values shown on the C-drawing.

### **Procedure**



**NOTE!** When viewing any of the following screens, if a key is not depressed within approximately 10 seconds, the ACU+ will automatically return to the Main screen.

1. With the Main screen displayed, press **ESC**. A screen displays the serial number and software version.
2. Press **ENT**. A screen displays the hardware version and MAC address.
3. Press **ENT**. A screen displays the configuration version number.
4. Press **ESC**, or wait approximately 10 seconds, to return to the Main screen.

## Checking Basic System Settings

Navigate through the controller menus and submenus to check system settings. You can adjust any parameter as required. Note that these settings can also be checked (and changed if required) via the WEB Interface.



**NOTE!** Repeatedly press the “ESC” key to return in reverse order level by level from any submenu until the Main screen appears.

### Procedure

- To Select a Sub-Menu:**  
Press the up or down arrow keys to move the cursor up and down the list of sub-menus in the menu screen (selects the sub-menu), then press **ENT** to enter the selected sub-menu.
- To Select a User:**  
To select a User, use the UP or DOWN arrow keys to move the cursor to the Select User field. Press ENT. Use the UP and DOWN keys to select a User previously programmed into the ACU+. Press ENT to select the User. Note that only Users programmed into the ACU+ are shown. Users are programmed via the Web Interface. The default User is admin.
- To Enter a Password:**  
If a password screen opens, a password must be entered to allow the User to make adjustments. To enter a password, use the UP and DOWN keys to move the cursor to the Enter Password field. Press ENT. Use the UP and DOWN keys to choose a character. Press ENT to accept and move to the next character. Continue this process until all characters are entered. Press ENT again to accept the password. The default password is 1.
- To Change a Parameter:**  
Press the up or down arrow keys to move the cursor up and down the list of parameters in the menu screen (selects the parameter to change), then press **ENT** to change the selected parameter. The parameter field highlights. Press the up or down arrow keys to change the parameter value. Press **ENT** to confirm the change.

**Table 7** shows the menu navigation for some basic settings. Refer to the separate ACU+ Manual (UM1M820BNA or UM1M820DNA400) supplied with your power system for complete Local Display menus.

**Table 7.1 ACU+ Basic Settings Menu Navigation**

Parameter	Menu Navigation
Date	Main Menu / Settings / Controller / Date
Time	Main Menu / Settings / Controller / Time
IP Communications Parameters (IP address, subnet mask address, gateway address)	Main Menu / Settings / Communication
Float Voltage	Main Menu / Settings / Battery / Charge / Float Voltage
Equalize Voltage	Main Menu / Settings / Battery / Charge / EQ Voltage
Battery Capacity	Main Menu / Settings / Battery / Battery 1 / Rated Capacity
BTRM Feature	Main Menu / Settings / Battery / Basic / BTRM Action Main Menu / Settings / Battery / Basic / BTRM Voltage
Temperature Compensation Center Temperature	Main Menu / Settings / Battery / Temp Comp / Temp Comp Center
Temperature Compensation Slope	Main Menu / Settings / Battery / Temp Comp / Temp Comp Coeff
Temperature Compensation Sensor	Main Menu / Settings / Battery / Temp Comp / TempComp Sensor
Temperature Compensation Maximum Voltage	Main Menu / Settings / Battery / Temp Comp / Temp Comp Max V
Temperature Compensation Minimum Voltage	Main Menu / Settings / Battery / Temp Comp / Temp Comp Min V
HVSD Limit	Main Menu / Settings / Rectifier / All Rect Set / HVSD Limit
Rectifier Current Limit	Main Menu / Settings / Rectifier / All Rect Set / Curr Limit Pt
Over Voltage Alarm 1	Main Menu / Settings / Power System / General / Over Voltage 1
Over Voltage Alarm 2	Main Menu / Settings / Power System / General / Over Voltage 2
Under Voltage Alarm 1	Main Menu / Settings / Power System / General / Under Voltage 1
Under Voltage Alarm 2	Main Menu / Settings / Power System / General / Under Voltage 2



## **Changing Battery Capacity Rating in the ACU+**

To change the battery capacity setting of the ACU+ to match the battery connected to the power system, perform the following procedure.

### **Procedure**

1. With the Main screen displayed, press **ENT** to go to the Main Menu. Navigate to and select "**Settings**" (ENT).
2. If a password screen opens, a password must be entered to allow the User to make adjustments. If a password was previously entered and has not yet timed out, skip this step and proceed to step 3). Otherwise, to enter a password, with the cursor at the User Name field (default is "Admin"), press the down arrow key to move cursor down to the password line. Press **ENT**. "0" is highlighted. Press the up arrow key once to change the "0" to "1" (default password is "1"), then press **ENT** twice. (*Note: If you have been assigned a unique User Name and password, follow this procedure to enter these.*)
3. With the Settings menu screen displayed, navigate to and select "**Battery**" (ENT) / "**Battery 1**" (ENT).
4. Navigate to "**Rated Capacity**". Press **ENT**. Use the up or down keys to adjust the value as required. Press **ENT**.
5. Return to the Main screen by repeatedly pressing **ESC** (escape).

## **Configuring the ACU+ Identification of Rectifiers and Assigning which Input Phase is Connected to the Rectifiers**

When rectifiers are all installed prior to applying power and starting the system, the order in which the ACU+ identifies the rectifiers is by serial number (lowest serial number is Rect 1, next lowest is Rect 2, etc.). If you prefer the ACU+ to identify the rectifiers by position in the system, perform the following procedure.

Upon power up, the ACU+ arbitrarily assigns Phase A, B, or C to each rectifier. This assignment is used to display rectifier AC input phase voltage(s). The User may reassign the phase to each rectifier per your specific installation by following the procedure below.

### **Procedure**

1. With the Main screen displayed, press **ENT** to go to the Main Menu. Navigate to and select "**Settings**" (ENT).
2. If a password screen opens, a password must be entered to allow the User to make adjustments. If a password was previously entered and has not yet timed out, skip this step and proceed to step 3). Otherwise, to enter a password, with the cursor at the User Name field (default is "Admin"), press the down arrow key to move cursor down to the password line. Press **ENT**. "0" is highlighted. Press the up arrow key once to change the "0" to "1" (default password is "1"), then press **ENT** twice. (*Note: If you have been assigned a unique User Name and password, follow this procedure to enter these.*)
3. With the Settings menu screen displayed, navigate to and select "**Rectifier**" (ENT).
4. Navigate to "**Rect #**" (# is used here to represent the rectifier identification number). Press **ENT**. The rectifier # menu screen is displayed, and the green LED on one rectifier starts flashing. This is the rectifier currently identified by the ACU+ as rectifier #. (If this is not the rectifier you want, press **ESC** to return to rectifier menu screen and select a different rectifier.)
5. If you wish to change the Rectifier IDs, navigate to and select "**Rectifier ID**". Press **ENT**. Use the up or down keys to change the ACU+ identification number for the flashing rectifier. Press **ENT**.
6. If you wish to change the Rectifier Phase Assignment, navigate to and select "**Rect Phase**". Press **ENT**. Use the up or down keys to change the phase connected to the flashing rectifier. Press **ENT**.



**NOTE!** The new ID and/or phase assignment will not take effect until this entire procedure is completed and the new ID's have been confirmed.

7. Press **ESC** to return to rectifier menu screen.
8. Navigate to and select the next rectifier.

9. Repeat steps 4) through 8) for each of the remaining rectifiers in the system.
10. When you have finished selecting identification numbers for all rectifiers, repeatedly press **ESC** to return to the Main Menu.
11. Navigate to and select "**Manual**" (ENT) / "**Rectifier**" (ENT) / "**All Rect Ctrl**" (ENT).
12. Navigate to "**Confirm ID/PH**". Press **ENT**. "**Yes**" highlights.
13. Press **ENT** to select the operation. Press **ENT** again to confirm.



**NOTE!** Check you numbering to be sure it is correct. If there where conflicts in your numbering, rectifiers with conflicts will be assigned the next available sequential number.

14. Return to the Main screen by repeatedly pressing **ESC** (escape).

### **Configuring the ACU+ Identification of Converter Modules**

When converters are all installed prior to applying power and starting the system, the order in which the ACU+ identifies the converters is by serial number (lowest serial number is Conv 1, next lowest is Conv 2, etc.).

If you prefer the ACU+ to identify the converters by position in the system, perform the following procedure.

#### **Procedure**

1. With the Main screen displayed, press **ENT** to go to the Main Menu. Navigate to and select "**Settings**" (ENT).
2. If a password screen opens, a password must be entered to allow the User to make adjustments. If a password was previously entered and has not yet timed out, skip this step and proceed to step 3). Otherwise, to enter a password, with the cursor at the User Name field (default is "Admin"), press the down arrow key to move cursor down to the password line. Press **ENT**. "0" is highlighted. Press the up arrow key once to change the "0" to "1" (default password is "1"), then press **ENT** twice. (*Note: If you have been assigned a unique User Name and password, follow this procedure to enter these.*)
3. With the Settings menu screen displayed, navigate to and select "**Converter**" (ENT).
4. Navigate to "**Conv #**" (# is used here to represent the converter identification number). Press **ENT**. The converter # menu screen is displayed, and the green LED on one converter starts flashing. This is the converter currently identified by the ACU+ as converter #. (If this is not the converter you want, press **ESC** to return to converter menu screen and select a different converter.)
5. Navigate to and select "**Set Conv ID**". Press **ENT**. Use the up or down keys to change the ACU+ identification number for the flashing converter. Press **ENT**.
6. Press **ESC** to return to converter menu screen.
7. Navigate to and select the next converter.
8. Repeat steps 4) through 7) for each of the remaining converters in the system.
9. When you have finished selecting identification numbers for all converters, repeatedly press **ESC** to return to the Main Menu.
10. Navigate to and select "**Manual**" (ENT) / "**Converter**" (ENT) / "**All Conv Ctrl**" (ENT).
11. Navigate to "**Confirm ID**". Press **ENT**. "**Yes**" highlights.
12. Press **ENT** to select the operation. Press **ENT** again to confirm.



**NOTE!** Check you numbering to be sure it is correct. If there where conflicts in your numbering, converters with conflicts will be assigned the next available sequential number.

13. Return to the Main screen by repeatedly pressing **ESC** (escape).

### **ACU+ Alarm Relay Check**

To verify operation of the external alarm relays, use the ACU+ alarm relay test feature. Refer to the ACU+ Instructions (UM1M820BNA or UM1M820DNA400) for instructions in using this feature.



**NOTE!** *The relays may be preprogrammed for specific functions. Refer to the configuration drawing (C-drawing) supplied with your system for your system's specific configuration.*

## 7.4 NCU Controller Procedure

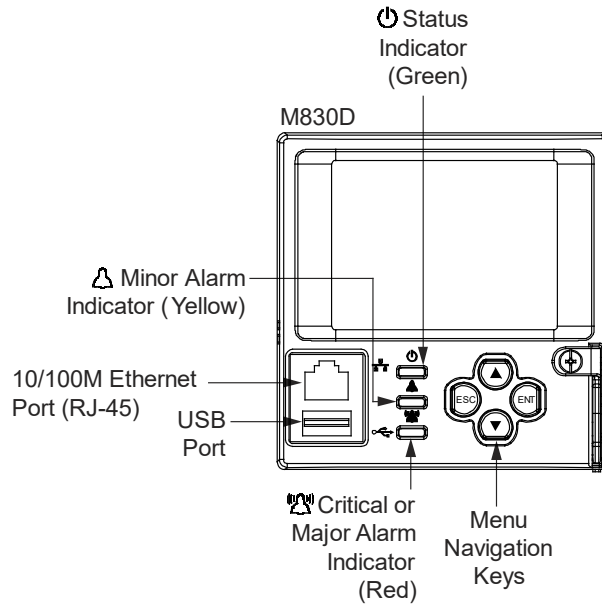
Refer to this section if your system is furnished with an NCU Controller.

### **NCU Controller Initialization**

Refer to the NCU Instructions (UM1M830BNA) for detailed instructions.

Refer to **Figure 80** for locations of the NCU local indicators and navigation keys.

**Figure 7.2** NCU Local Indicators and Navigation Keys



### **Procedure**



**NOTE!** The initialization routine takes several minutes. During that time various alarm indicators may illuminate on the NCU front panel and an audible alarm may sound. Disregard all alarms. An audible alarm can be silenced at any time by momentarily depressing the **ENT** key on the NCU Controller.

1. After the NCU is powered on, the display shows the “**logo**” screen. The controller is initializing.
2. When initialization is complete, the language screen appears. Press the up or down arrow key to select the desired language. Press the **ENT** key to confirm the selection.
3. The Main Menu displays. See **Figure 81**.

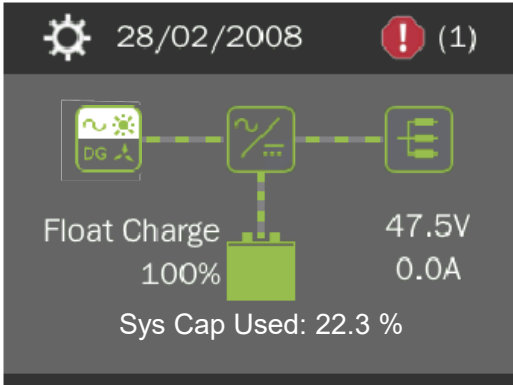
Figure 7.3 NCU Local Display Main Menu

## Main Menu

Date and time are  
alternately displayed.

Green - No Alarm  
Red - Alarm

The number in ( ) indicates  
the total number of alarms.



Press the UP and DOWN keys to highlight  
the desired Menu graphic in the Main Menu.

Press the ENT key to enter the selected menu.

Graphics	Menu Name	Description
	Alarm (Green - No Alarm) (Red - Alarm)	View active alarms and alarm history.
	Settings	Gain access to the NCU Controller's settings menus.
	Input Power	View AC, Solar, DG, and Wind related information.
	Module	View rectifier, solar converter, and converter module related information.
	DC	View DC equipments related information.
	Battery	View battery related information.

To reboot the Controller, from the Main Menu press the ENT and ESC  
keys at the same time. Release both keys. Press ENT to confirm.

- System information is displayed in multiple screens. Press the ESC key to view other system information. Press the down arrow key to view the next screen. Press the ESC key to return to the Main Menu.
- From the Main Menu, press the UP and DOWN keys to highlight the desired Menu graphic in the Main Menu. Press the ENT key to enter the selected menu.



**NOTE!** Repeatedly press the "ESC" key to return in reverse order level by level from any submenu until the Main Menu appears.

- Verify and set the NCU controller as required for your application. Refer to the NCU Instructions (UM1M830BNA) for procedures. Note that you will have to program the NCU for any temperature probes and external inputs/outputs connected to the IB2 Interface Board, optional EIB Interface Board, and optional SM-DU+ Shunt Interface Board. Refer also to "NCU Start Wizard" on page 112.



**NOTE!** When setting total rectifier or total converter current limit, the set point to each unit is the total set point divided by the number of units. For example, if the system contains five rectifiers and the current limit is set to 150 amps then each rectifier has a current limit set point of 30 amps. If one or more rectifiers or converters are removed or fail it will take several seconds for the individual set points to the remaining rectifiers or converters to be reset. In the example given, if one rectifier is removed the current limit set point will drop to 120 amps (30 amps times four remaining rectifiers) until the controller can send updated set points to the remaining rectifiers. This takes a couple communication cycles (several seconds) after which each rectifier would have a new set point of 37.5 amps for a total of 150 amps. The total current limit of the rectifiers and converters should not be set such that the loss of the redundant rectifiers or converters will cause this temporary set point to drop below the actual maximum expected load. If batteries are used on the rectifier output, the batteries should support the load until the current limit set points can be re-established due to loss of a rectifier.

## NCU Start Wizard

For initial startup, you can perform the Start Wizard from the local keypad and display to enter basic programmable parameters in one session. Refer to the “Start Wizard” section in the NCU Instructions (UM1M830BNA).

## Verifying the Configuration File

Your NCU was programmed with a configuration file that sets all adjustable parameters. The version number of the configuration file can be found on the configuration drawing (C-drawing) that is supplied with your power system documentation, and on a label located on the NCU. You can verify that the correct configuration file has been loaded into your NCU by performing the following procedure.



**NOTE!** *The quantity of LVD's and shunt values for your specific system may be different from the values shown on the C-drawing.*

### Procedure

1. With the Main Menu displayed, press **ESC**. A screen displays the NCU name, serial number, IP number, software version, hardware version, and configuration version number.
2. Press the **DOWN** key. A screen displays the NCU file system and MAC address.
3. Press **ESC** to return to the Main Menu.

## Checking Basic System Settings

Navigate through the controller menus and submenus to check system settings. You can adjust any parameter as required. Note that these settings can also be checked (and changed if required) via the WEB Interface. Refer also to “NCU Start Wizard” on page 112.



**NOTE!** *Repeatedly press the “ESC” key to return in reverse order level by level from any submenu until the Main Menu appears.*

### Procedure

1. **To Select a Sub-Menu:**  
Press the UP and DOWN keys to highlight the desired sub-menu. Press the ENT key to enter the selected sub-menu.
2. **To Select a User:**  
To select a User, use the UP and DOWN keys to move the cursor to the Select User field. Press ENT. Use the UP and DOWN keys to select a User previously programmed into the NCU. Press ENT to select the User. Note that only Users programmed into the NCU are shown. Users are programmed via the Web Interface. The default User is admin.
3. **To Enter a Password:**  
To enter a password, use the UP and DOWN keys to move the cursor to the Enter Password field. Press ENT. Use the UP and DOWN keys to choose a character. Press ENT to accept and move to the next character. Continue this process until all characters are entered. Press ENT again to accept the password. The default password is 640275.
4. **To Change a Parameter:**  
Press the UP and DOWN keys to move up and down the list of parameters. Press ENT to select the parameter. Press the UP and DOWN keys to change the parameter. Press ENT to make the change. Press ESC to cancel the change.

**Table 8** shows the menu navigation for some basic settings. Refer to the separate NCU Manual (UM1M830BNA) supplied with your power system for complete Local Display menus.



**NOTE!** If an NCU configuration is furnished that enables NCU capability to receive status information sent from Fiamm SoNick (Sodium Nickel) batteries, some NCU parameters cannot be changed. Refer to the NCU controller manual UM1M830BNA for details.

**Table 7.2** NCU Basic Settings Menu Navigation

Parameter	Menu Navigation
Date	Main Menu / Settings Icon / Sys Settings / Date.
Time	Main Menu / Settings Icon / Sys Settings / Time.
IP Communications Parameters (IP address, subnet mask address, gateway address)	Main Menu / Settings Icon / Comm Settings / enter parameters.
Float Voltage	Main Menu / Settings Icon / Batt Settings / Charge / Float Voltage.
Equalize Voltage	Main Menu / Settings Icon / Batt Settings / Charge / EQ Voltage.
Battery Capacity	Main Menu / Settings Icon / Batt Settings / Batt1 Settings or Batt2 Settings / Rated Capacity.
Battery Charge Temperature Compensation	Main Menu / Settings Icon / Batt Settings / Temp Comp (enter parameters).
Rectifier Current Limit	Main Menu / Settings Icon / Rect Settings / Current Limit (set to enabled) then set Curr Limit Pt.
Over Voltage Alarm 1	Main Menu / Settings Icon / Other Settings / Over Voltage 1.
Over Voltage Alarm 2	Main Menu / Settings Icon / Other Settings / Over Voltage 2.
Under Voltage Alarm 1	Main Menu / Settings Icon / Other Settings / Under Voltage 1.
Under Voltage Alarm 2	Main Menu / Settings Icon / Other Settings / Under Voltage 2.

## **Changing Battery Capacity Rating in the NCU**

Change the battery capacity setting of the NCU to match the battery connected to the power system.



**NOTE!** *Not available for NCU configuration that enables NCU capability to receive status information sent from Fiamm SoNick (Sodium Nickel) batteries.*

### **Local Menu Navigation:**

Main Menu / Settings Icon / Batt Settings / Batt1 Settings or Batt2 Settings / Rated Capacity.

### **Web Menu Navigation:**

Settings Menu / Battery Tab / Batt1 Rated Capacity and Batt2 Rated Capacity.

Refer to the NCU Instructions (UM1M830BNA) for detailed instructions.

## **Configuring the NCU Identification of Rectifiers and Assigning which Input Feed is Connected to the Rectifiers**

When rectifiers are all installed prior to applying power and starting the system, the order in which the NCU identifies the rectifiers is by serial number (lowest serial number is Rect 1, next lowest is Rect 2, etc.). If you prefer the NCU to identify the rectifiers by position in the system, perform the following procedure.

Upon power up, the NCU arbitrarily assigns Feed AC1, AC2, or AC3 to each rectifier. This assignment is used to display rectifier AC input feed voltage(s). The User may reassign the feed to each rectifier per your specific installation by following the procedure below.

### **Local Menu Navigation:**

None.

### **Web Menu Navigation:**

Refer to the NCU Instructions (UM1M830BNA) for detailed instructions.

## **Configuring the NCU Identification of Converters**

When converters are all installed prior to applying power and starting the system, the order in which the NCU identifies the converters is by serial number (lowest serial number is Conv 1, next lowest is Conv 2, etc.). If you prefer the NCU to identify the converters by position in the system, perform the following procedure.

### **Local Menu Navigation:**

None.

### **Web Menu Navigation:**

Refer to the NCU Instructions (UM1M830BNA) for detailed instructions.

## **NCU Alarm Relay Check**

To verify operation of the external alarm relays, use the NCU alarm relay test feature. Refer to the NCU Instructions (UM1M830BNA) for instructions in using this feature.



**NOTE!** *The relays may be preprogrammed for specific functions. Refer to the configuration drawing (C-drawing) supplied with your system for your system's specific configuration.*





















## 7.5 Checking System Status

### Procedure

1. Observe the status of the indicators located on the controller, rectifiers, and converters (if furnished). If the system is operating normally, the status of these is as shown in **Table 9**.

**Table 7.3 Status and Alarm Indicators**

Component	Indicator		Normal State
ACU+		Status (Green)	On
		Minor (Yellow)	Off
		Critical or Major Alarm (Red)	Off
NCU		Status (Green)	On
		Minor (Yellow)	Off
		Critical or Major Alarm (Red)	Off
Rectifier Modules	 or 	Power (Green)	On
	 or 	Protection (Yellow)	Off
	 or 	Alarm (Red)	Off
Converter Modules	 or 	Power (Green)	On
	 or 	Protection (Yellow)	Off
	 or 	Alarm (Red)	Off

## 7.6 Final Steps

### **Procedure**

1. If any controller configuration settings were changed, refer to the ACU+ Instructions (UM1M820BNA or UM1M820DNA400) or NCU Instructions (UM1M830BNA) and save a copy of the configuration file. This file can be used to restore the controller settings, if required, at a later date.



**NOTE!** Note that provided on a USB drive furnished with the system is a controller configuration drawing (C-drawing) and the controller configuration files loaded into the controller as shipped.

2. Close the distribution cabinet's front door and turn the latch clockwise to secure the door (system's in a relay rack), or close the system's enclosure door.
3. Verify all rectifier and converter modules and the controller are fully seated, latched, and the latch handle screws secured.
4. Verify there are no external alarms and the local indicators are as shown in **Table 9**.

## Connect with Vertiv on Social Media



<https://www.facebook.com/vertiv/>



<https://www.instagram.com/vertiv/>



<https://www.linkedin.com/company/vertiv/>



<https://www.twitter.com/vertiv/>



---

Vertiv.com | Vertiv Headquarters, 505 N Cleveland Ave, Westerville, OH 43082, USA

© 2023 Vertiv Group Corp. All rights reserved. Vertiv™ and the Vertiv logo are trademarks or registered trademarks of Vertiv Group Corp. All other names and logos referred to are trade names, trademarks or registered trademarks of their respective owners. While every precaution has been taken to ensure accuracy and completeness here, Vertiv Group Corp. assumes no responsibility, and disclaims all liability, for damages resulting from use of this information or for any errors or omissions.