



Liebert®

Load Bus Sync™ Controller

Installer/User Guide

for Liebert® NX™ 225-kVA – 600-kVA UPS

The information contained in this document is subject to change without notice and may not be suitable for all applications. While every precaution has been taken to ensure the accuracy and completeness of this document, Vertiv assumes no responsibility and disclaims all liability for damages resulting from use of this information or for any errors or omissions. Refer to other local practices or building codes as applicable for the correct methods, tools, and materials to be used in performing procedures not specifically described in this document.

The products covered by this instruction manual are manufactured and/or sold by Vertiv. This document is the property of Vertiv and contains confidential and proprietary information owned by Vertiv. Any copying, use or disclosure of it without the written permission of Vertiv is strictly prohibited.

Names of companies and products are trademarks or registered trademarks of the respective companies. Any questions regarding usage of trademark names should be directed to the original manufacturer.

Technical Support Site

If you encounter any installation or operational issues with your product, check the pertinent section of this manual to see if the issue can be resolved by following outlined procedures.

Visit <https://www.Vertiv.com/en-us/support/> for additional assistance.

TABLE OF CONTENTS

Important Safety Information	1
1 Load Bus Sync™ Controller	3
1.1 Synchronization-Control Configurations	4
1.1.1 Two Systems with Separate Utility Supplies	4
1.2 Two UPS Units With Common Bypass Line	6
1.3 Liebert® Systems with Electrical Generating Devices	8
1.4 Liebert® NX™ with a Third-Party UPS	9
2 Installation	11
2.1 Location Considerations	11
2.2 Connecting the Controller to the UPS System	11

This page intentionally left blank

IMPORTANT SAFETY INFORMATION

IMPORTANT! This manual contains important safety instructions that must be followed during the installation and maintenance of the UPS and batteries. Read this manual thoroughly and the safety and regulatory information, available at <https://www.vertiv.com/ComplianceRegulatoryInfo>, before attempting to install, connect to supply, or operate this equipment.

This page intentionally left blank

1 LOAD BUS SYNC™ CONTROLLER

The Liebert® Load Bus Sync™ Controller synchronizes complex power-source systems that consist of different distributions and static switches supplied by Vertiv and other manufacturers when synchronization cannot be guaranteed by the system configuration or when temporary conditions prevent it, for example, during battery operation.

The Load Bus Sync Controller is either a factory-installed option or a kit that is installed and configured by Vertiv-trained and certified personnel. The controller unit is housed in a metal enclosure that may be mounted near the UPS or inside the electrical distribution panel. It requires a 480V input reference supply and will supply two units.

The controller identifies one of the connected units as the master unit and uses its frequency as a reference for the other units ("slave" units). While a non-Liebert® UPS may be the master, only Liebert® UPSs can be slave units. Depending on the configuration, the slave units always follow the reference frequency or follow only when their reserve utility supply is out of tolerance. The reference frequency is generated only when the master utility-supply line is within acceptable limits.

The Load Bus Sync Controller may drive up to two separate units that operate independently or are connected in a parallel system.

NOTE: When an installation has more than two slave units, or master/slave configuration is not your preferred option, we suggest using a Liebert® MultiBus Synchronization Module™ (MBSM). Contact your Vertiv sales representative for details.

The Load Bus Sync Controller does not affect the system's mean time between failure (MTBF). It is not a single point of failure for the system. The individual units will ignore this signal if it is outside the acceptable limits.

The controller dimensions are 3.7 in. x 2.5 in. x 7.1 in. (94mm x 64 mm x 181 mm) width x height x depth.

Table 11 below describes the electrical characteristics.

Table 1.1 Electrical Characteristics of the Controller

CHARACTERISTIC	MINIMUM	NOMINAL	MAXIMUM
Supply voltage (50/60 Hz sinusoidal), volts	180	480	250
Supply current, mA	—	14	—
Output current (per channel), mA	25	—	30
Working temperature °F (°C)	14 (-10)	—	104 (40)
Phase stability error	—	0.18	—
Phase shift within voltage tolerance range, degrees *	—	1.5	°
* Voltage within ±10% of nominal value.			

Figure 1.1 Controller Front and Rear Panels

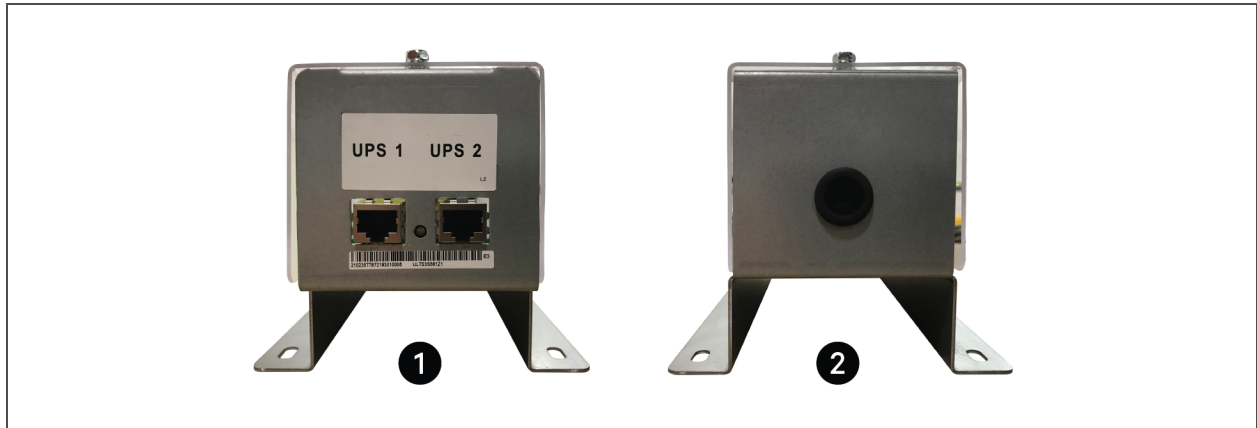

ITEM	DESCRIPTION
1	Front
2	Rear

1.1 Synchronization-Control Configurations

1.1.1 Two Systems with Separate Utility Supplies

When two UPSs are connected to separate power sources without the Load Bus Sync Controller, the inverters attempt to synchronize with their respective bypass lines, but the lines may not be in phase, so synchronization cannot be guaranteed. Even if the two units are supplied from a common line, when one or both is operating on-battery there is no common input signal, and the outputs will not be synchronized.

With the Load Bus Sync Controller, one of the UPS outputs is the master, and the other UPS (slave) outputs follow the master reference, see **Figure 1.2** on the facing page.

NOTE: Install N.B. fuses in the phase signal line, upstream of the Load Bus Sync Controller to protect against damage caused by short circuits. Configure UPS B, shown in **Figure 1.2** on the facing page, so that it follows the external synchronization signal by setting the main synchronization source to external signal. Otherwise, the UPS will be in phase with its own bypass line and follow external synchronization only when this is out of tolerance.

Figure 1.2 Two Separate Utility Supplies

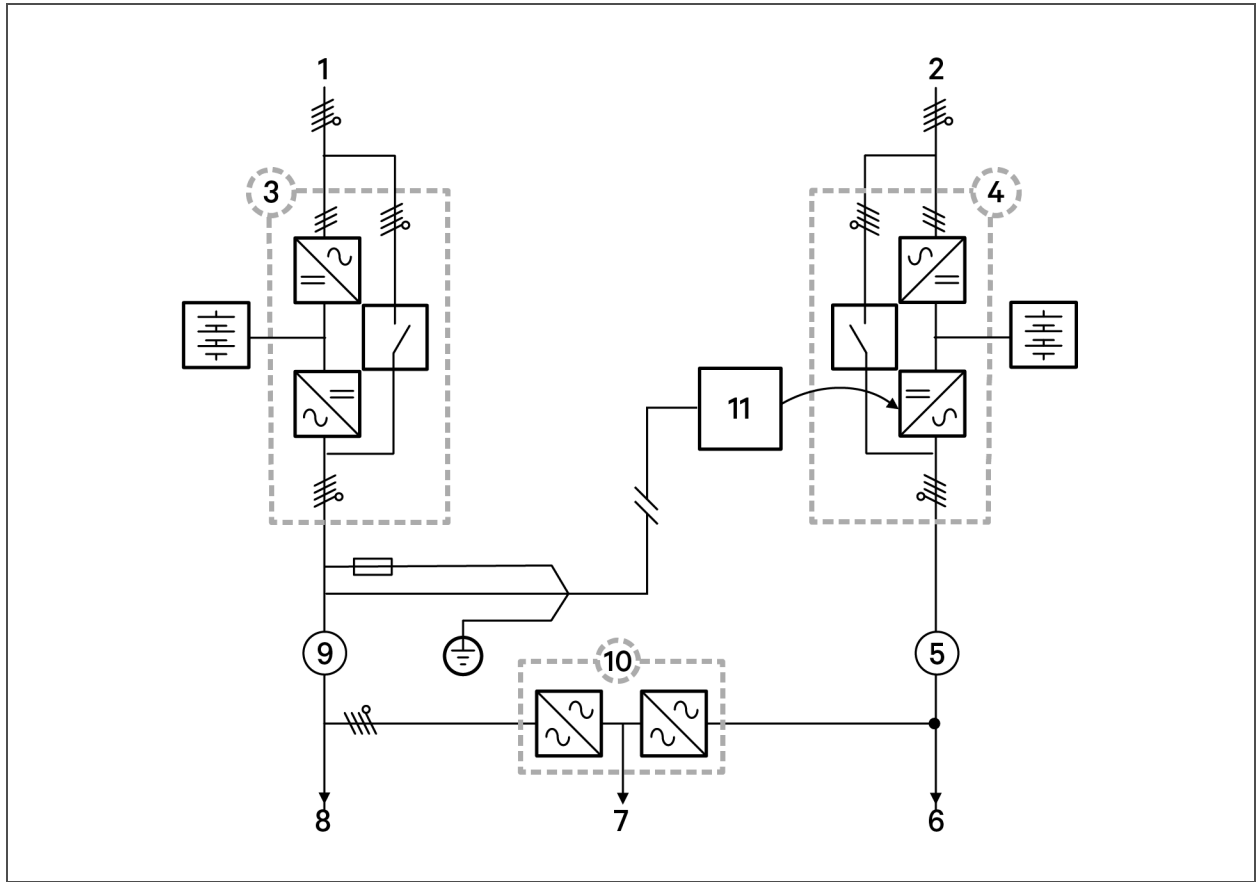

ITEM	DESCRIPTION
1	Power Source A
2	Power Source B
3	Master
4	Slave
5	Source Line B
6	"To others" Static Switch
7	To load
8	"To others" Static Switch
9	Source Line A
10	Static Switch
11	Load Bus Sync Controller

1.2 Two UPS Units With Common Bypass Line

When two UPSs are connected with a common bypass line without the Load Bus Sync Controller, the bypass line synchronizes the inverters. Synchronization can be lost because of upstream protection of the bypass line. Using the Load Bus Sync Controller as shown in **Figure 1.3** below, the systems are always synchronized, even if one of the bypass lines is out of tolerance, and are usually capable of synchronous operation.

NOTE: Install N.B. fuses at the beginning of the signal line to avoid fires in case of short circuit in the wires. Configure both UPS systems with main synchronization source to bypass. Otherwise the UPSs will not be capable of synchronous transfer to bypass.

Figure 1.3 Common Bypass Line

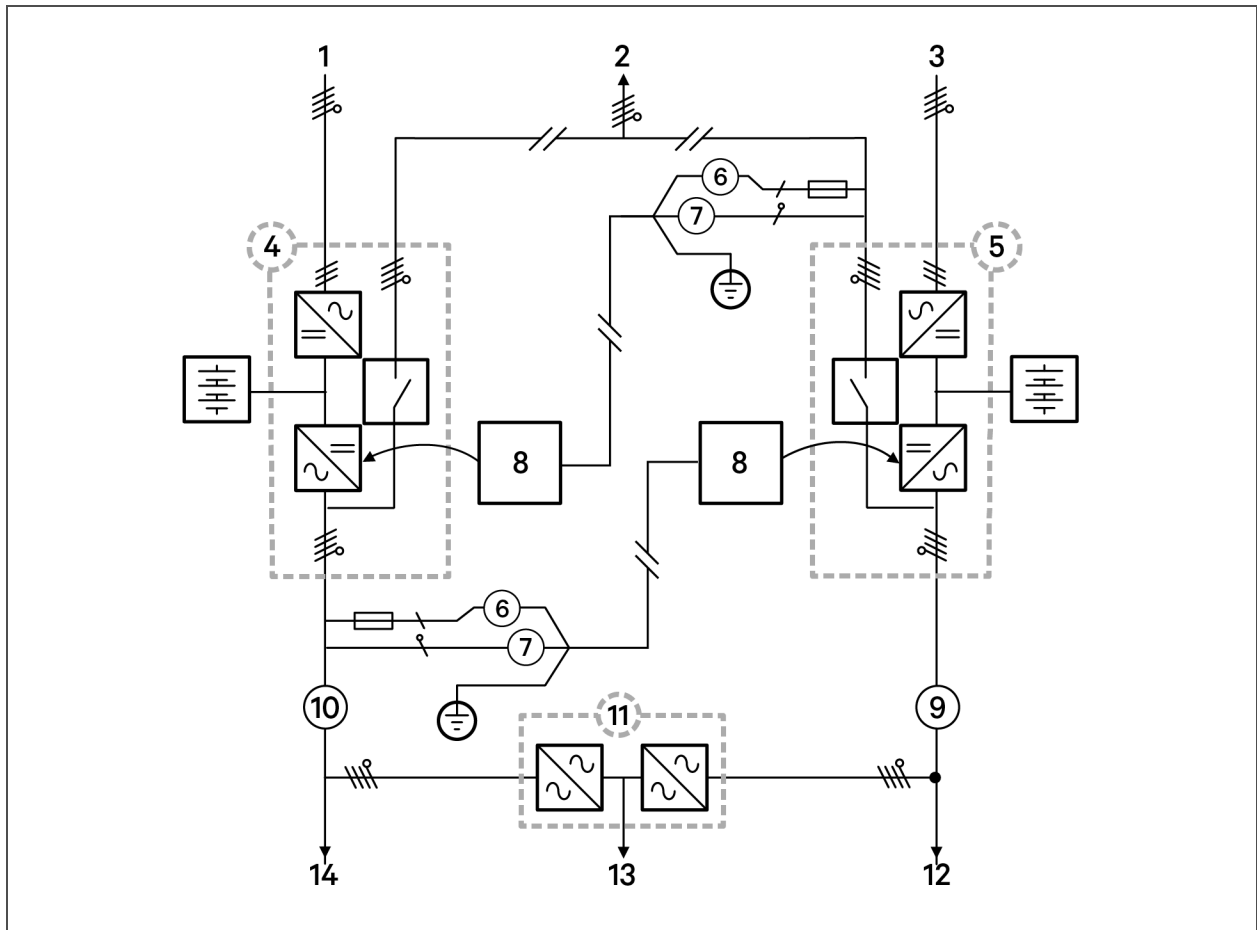

ITEM	DESCRIPTION
1	Power Source A
2	Common Bypass Line
3	Power Source B
4	UPS A
5	UPS B
6	Phase A
7	Phase C
8	Load Bus Sync Controller
9	Source Line B
10	Source Line A
11	Static Switch
12	"To others" Static Switch
13	To load
14	"To others" Static Switch

1.3 Liebert® Systems with Electrical Generating Devices

The Load Bus Sync Controller provides phase reference to Liebert® UPS installations with alternative power sources, such as diesel generators, see **Figure 1.4** below.

NOTE: N.B. fuses should be installed in the phase signal line, upstream of the Load Bus Sync Controller to protect against the damage caused by short circuits.

Figure 1.4 Liebert® UPS Systems and an Alternative Power Source

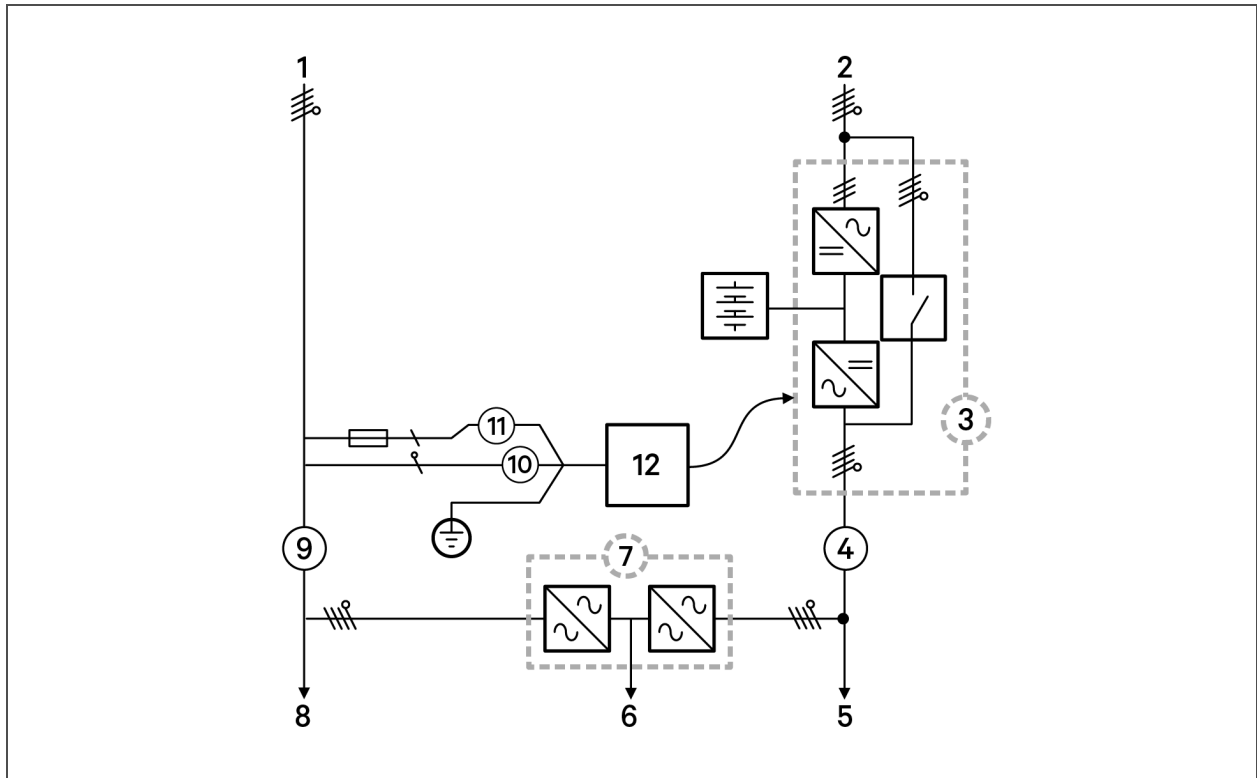

ITEM	DESCRIPTION
1	Power Source A, Alternate Power Source
2	Power Source B, NX Power Source
3	UPS
4	Source Line B
5	"To Others" Static Switch
6	To Load
7	Static Switch
8	"To Others" Static Switch
9	Source Line A

ITEM	DESCRIPTION
10	Phase A
11	Phase C
12	Load Bus Sync Controller

1.4 Liebert® NX™ with a Third-Party UPS

The Load Bus Sync Controller synchronizes Liebert® NX™ UPSs with UPS systems made by another company. In this scenario, the Liebert® units must be configured as slave devices to follow the phase reference signal derived from the non-Liebert® master UPS. The Liebert® units may be configured as parallel or single units, see **Figure 15** on the next page.

NOTE: Configure all of the Liebert® UPSs to follow the external synchronization signal by setting the main synchronization source to external signal. If not set to follow the external synchronization signal, the UPSs will be in phase with their own bypass line and will follow external synchronization only when the bypass line is out of tolerance.

Figure 1.5 Liebert® System and Third-Party UPS

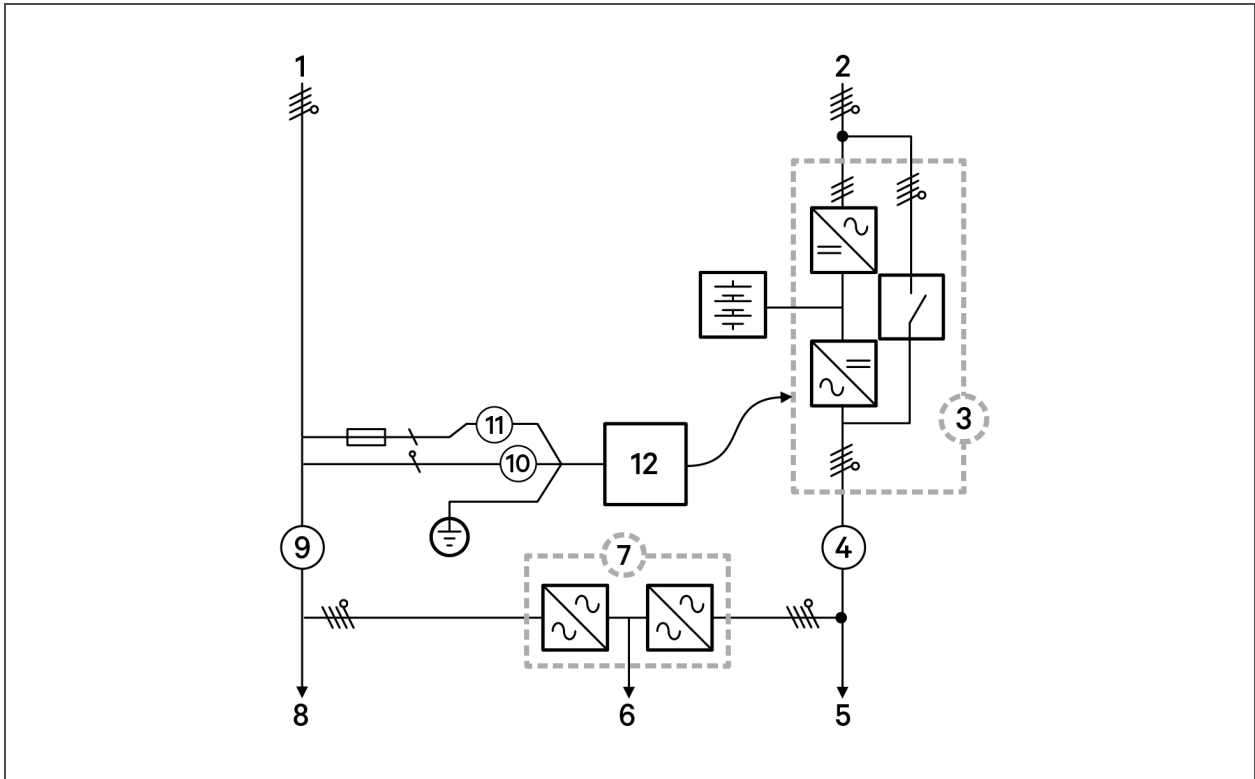

ITEM	DESCRIPTION
1	Power Source A, Third-Party (non-Vertiv) Power Source
2	Power Source B, NX Power Source
3	UPS
4	Source Line B
5	"To others" Static Switch
6	To load
7	Static Switch
8	"To others" Static Switch
9	Source Line A
10	Phase A
11	Phase C
12	Load Bus Sync Controller

2 INSTALLATION



CAUTION: Risk of improper electrical connections. Can cause equipment damage. The Load Bus Sync Controller must be supplied from L1 and L3.

2.1 Location Considerations

Observe the following guidelines when installing the Load Bus Sync Controller:

- When installed inside a distribution panel or UPS, ensure that the metal box is secured so that it cannot fall or touch metal parts containing hazardous voltages.
- Do not install behind the second access panel or in front of the UPS air inlet vents.
- The connections to the slave units must be as short as possible.
- Install a 2-A slow-blow fuse on the phase signal line, as close as possible to the master unit.

2.2 Connecting the Controller to the UPS System

Referring to **Figure 11** on page 4, for the connection locations:

1. Using a female IEC 10 A plug and a suitable power cable, connect the PE, master-Phase A and Phase C to the reference signal input on the rear of the Load Bus Sync Controller.
2. Using an RJ-45 cable, connect the slave UPS X20 connection (on the UPS customer connectivity panel) to UPS 1 port on the front of the Load Bus Sync Controller.
3. Once the connections are complete, contact Vertiv for the final setup and calibration. The setup and calibration must be performed by an authorized Vertiv technician.

This page intentionally left blank





Vertiv.com | Vertiv Headquarters, 1050 Dearborn Drive, Columbus, OH, 43085, USA

© 2019 Vertiv Group Corp. All rights reserved. Vertiv and the Vertiv logo are trademarks or registered trademarks of Vertiv Group Corp. All other names and logos referred to are trade names, trademarks or registered trademarks of their respective owners. While every precaution has been taken to ensure accuracy and completeness herein, Vertiv Group Corp. assumes no responsibility, and disclaims all liability, for damages resulting from use of this information or for any errors or omissions. Specifications are subject to change without notice.

SL-70439_REVO_11-19